

# MUFON UFO JOURNAL

NUMBER 212

DECEMBER 1985

Founded 1967

OFFICIAL PUBLICATION OF



MUTUAL UFO NETWORK, INC.

\$1.50



**"FIRST NIGHT COLOR UFO PICTURE"**

**MUFON UFO JOURNAL**  
 (USPS 002-970)  
 (ISSN 0270-6822)  
 103 Oldtowne Rd.  
 Seguin, Texas 78155-4099

**DENNIS W. STACY**  
 Editor

**WALTER H. ANDRUS, JR.**  
 International Director and  
 Associate Editor

**THOMAS P. DEULEY**  
 Art Director

**MILDRED BIESELE**  
 Contributing Editor

**ANN DRUFFEL**  
 Contributing Editor

**TED BLOECHER**  
**DAVE WEBB**  
 Co-Chairmen,  
 Humanoid Study Group

**PAUL CERNY**  
 Promotion/Publicity

**MARGE CHRISTENSEN**  
 Public Relations

**REV. BARRY DOWNING**  
 Religion and UFOs

**LUCIUS FARISH**  
 Books/Periodicals/History

**ROSETTA HOLMES**  
 Promotion/Publicity

**T. SCOTT CRAIN**  
**GREG LONG**  
 Staff Writer

**JAMES LEMING**  
**SIMONE MENDEZ**  
 Staff Artists

**TED PHILLIPS**  
 Landing Trace Cases

**JOHN F. SCHUESSLER**  
 Medical Cases

**LEONARD STRINGFIELD**  
 UFO Crash/Retrieval

**WALTER N. WEBB**  
 Astronomy

**NORMA E. SHORT**  
**DWIGHT CONNELLY**

**DENNIS HAUCK**  
**RICHARD H. HALL**

**ROBERT V. PRATT**  
 Editor/Publishers Emeritus

The MUFON UFO JOURNAL is published by the Mutual UFO Network, Inc., Seguin, Texas. Membership/Subscription rates: \$15.00 per year in the U.S.A.; \$16.00 foreign in U.S. funds. Copyright 1985 by the Mutual UFO Network. Second class postage paid at Seguin, Texas. POSTMASTER: Send form 3579 to advise change of address to The MUFON UFO JOURNAL, 103 Oldtowne Rd., Seguin, Texas 78155.

# FROM THE EDITOR

We would like to take this opportunity to correct a couple of recent errors in the Journal. The uncredited critical review of "Clear Intent" which appeared in last issues "News'N'Views" was written by Robert Wanderer, and in no way did or does reflect the opinion either of the editor of the Journal or MUFON itself. As with any open forum, the opinions expressed in reviews or articles are solely those of the author.

Secondly, the article "UFO Lifting Power" by Staff Writer T. Scott Crain in the October 1985 issue of the Journal, originally appeared in the Summer 1984 number of "Search" Magazine, Palmer Publications, Inc., Amherst, Wisconsin.

Our apologies to those involved, and we hope this clears up any misunderstandings that might have arisen due to our editorial oversight.

## In this issue

FIRST COLOR NIGHT PHOTOGRAPH, by Walt Andrus .....	3
SECURITY POLICY, by Donald M. Ware .....	7
PENN STATE SIGHTING, by Stan Gordon .....	8
THE BENTWATERS INCIDENT, by Ray Boeche .....	10
RENDELSHAM REPLY (Query by J.R. Kyniston) .....	12
MUTE EVIDENCE REVISITED, by Richard D. Seifried .....	13
INVISIBLE UFO, by Francis Ridge .....	15
A UNIQUE CATALOG, Dr. Willy Smith .....	16
IN OTHER'S WORDS, by Lucius Farish .....	17
LETTERS .....	17
DIRECTOR'S MESSAGE .....	20
COVER by Jim Wolfe	

The Mutual UFO Network, Inc. is exempt from Federal Income Tax under Section 501(c)(3) of the Internal Revenue Code. MUFON is a publicly supported organization of the type described in Section 509(a)(2). Donors may deduct contributions from their Federal income tax. In addition, bequests, legacies, devises, transfers, or gifts are deductible for Federal estate and gift tax purposes if they meet the applicable provisions of Sections 2055, 2106, and 2522 of the code.

The contents of the MUFON UFO JOURNAL are determined by the editor, and do not necessarily represent the official position of MUFON. Opinions of contributors are their own, and do not necessarily reflect those of the editor, the staff, or MUFON. Articles may be forwarded directly to MUFON. Responses to published articles may be in a Letter to the Editor (up to about 400 words) or in a short article (up to about 2,000 words). Thereafter, the "50% rule" is applied: the article author may reply but will be allowed half the wordage used in the response; the responder may answer the author but will be allowed half the wordage used in the author's reply, etc. All submissions are subject to editing for style, clarity, and conciseness.

Permission is hereby granted to quote from this issue provided not more than 200 words are quoted from any one article, the author of the article is given credit, and the statement "Copyright 1985 by the Mutual UFO Network, 103 Oldtowne Rd., Seguin, Texas" is included.

# FIRST COLOR NIGHT PHOTOGRAPH

By Walt Andrus

At approximately 1:45 a.m. on August 2, 1965, Alan R. Smith, age 14, standing in the back yard of his Tulsa, Oklahoma home, pointed his small camera toward the darkened sky and clicked the shutter. The image he recorded on the color negative has become noteworthy in Ufology. Alan was sighting his camera at an unidentified flying object in the sky. He and his father had observed a possible UFO on the previous night, August 1, however on this night they were prepared.

## NEGATIVE

The negative shows an orange, blue, and whitish egg-shaped object, clearly defined in the sky. Protruding from the object are three tiny fingers. Dark bands bisect the colored segments. The picture was taken during the August 1-5, 1965 UFO flap that extended from Oklahoma, Texas and Kansas to California. For the first three days of this flap, Tinker AFB in Oklahoma City, Oklahoma and Carswell AFB in Ft. Worth, Texas confirmed sightings on their radars as fast as State Troopers in both states reported visual sightings. The Pentagon issued orders on August 4th to both USAF installations to refrain from cooperating with the State Police Agencies and provided their own casual and unlikely explanation for the hundreds of sightings. The night time sightings were attributed to the constellation Orion.

## THE OBJECT

Alan said the second night he and his family were ready in case the object returned. He had loaded his official Boy Scout Camera (620) with Kodacolor X high speed film. When Alan was interviewed by the author in Tulsa nearly a year later, he said it (the object) moved from west to east and estimated

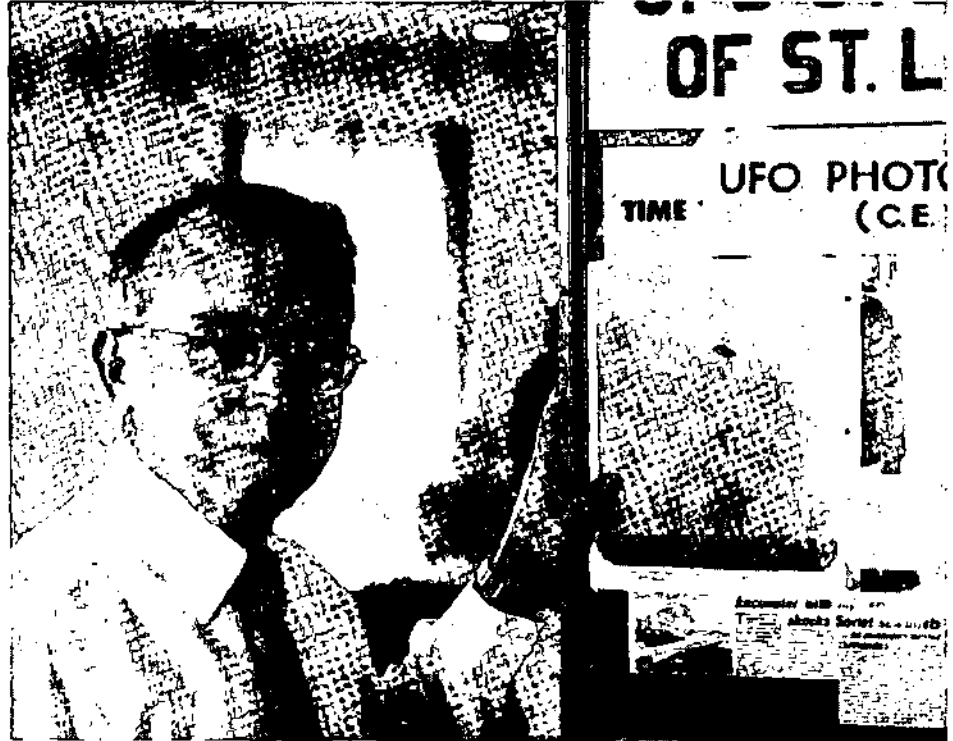

AUTHOR AT ST. LOUIS SYMPOSIUM

Dennis Stacy

that it looked to be the size of a basketball or soccer ball. "It again appeared as a ball of light, but moved slower than the first night. It was changing color from white, to red to blue-green. Its light pulsed and a high whining sound was being emitted. As the sound grew louder, the light became brighter." When I questioned him about the sound, he said "it sounded like his mother's vacuum sweeper." His father confirmed this explanation, since I interviewed both witnesses in sequence.

## WITNESSES

This case has all the attributes of an authentic UFO photograph. There were five witnesses to the object and four of them observed Alan taking the photograph. They included Alan; his father, A.L. Smith, 43, a turbine engine inspector for American Airlines in

Tulsa; his sister Sheryle Holt, 18; Sheryle's husband, Ron Holt, 18, and a neighbor boy, Daryl Swimmer, 15. At that time, Alan's family lived at 4719 S. 29 West, Tulsa, Okla. and the Swimmer family at 4721 S. 29W. All gave the same basic description of the light in the sky but pointed out that it did not appear the same as it does in Alan's color picture. "It was just a blob of light" his sister said to a reporter from *The Oklahoma Journal* newspaper which obtained copyrights on the photograph.

When it (the UFO) was almost directly overhead — about 11 o'clock high — Alan relates, he raised his camera and shot the picture. He exposed only one negative, because in the dark he could not see the next number in the window area to wind the film forward.

(continued next page)

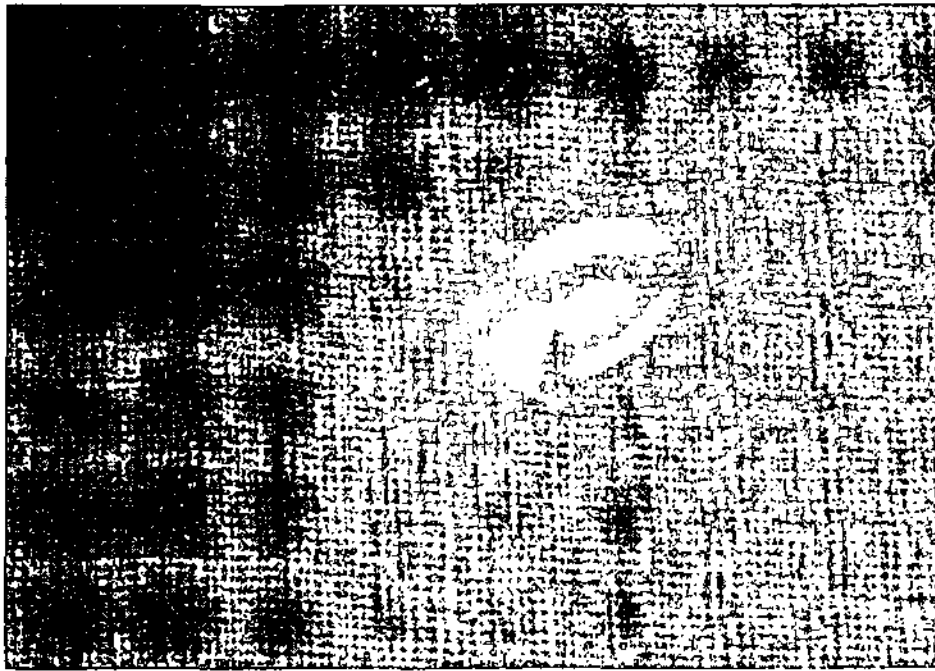

UFO AT NIGHT

Alan R. Smith

## PHOTO, Continued

### ALMOST LOST

The family waited 7 to 10 days before sending the film out for normal commercial processing, since they wanted to use the entire roll. The film was sent to Exel Camera Store in downtown Tulsa for processing. "When we got the film back," Mrs. Smith explained, "we were all disappointed. There was nothing in Alan's prints of the flying object.

"Then we started looking at the negatives and saw that the film company had not printed two of the negatives. One had a streak of light and the other had an object in one corner that appeared to be three or four colors," she said.

"We took it back to the film company and had them make an enlargement of that negative. The result was the UFO that had appeared over our backyard. The camera had gotten distinct lines of an object — while our eyes saw only a large round circle of light," she said. Mr. Smith said the object appeared to be about 36 to 40 feet in diameter and about 5,000 to 8,000 feet high. He based this upon his experience of visual sightings of aircraft in his work, etc.

On the second night, August 2,

when the picture was made, the object was in view for five minutes moving southwest to east. Alan said he saw the object, walked 25 feet to this house, picked up the camera, returned outside and waited until it was almost overhead before exposing the one negative.

### SOUNDS & COLORS

Members of the family said they heard a whine increase as the object speeded up. There was also an increase in the intensity of the light. It first appeared white as a star, turning red as it came closer, gyrating, turning blue, then green then white, Mr. Smith said. The object appeared as if it were illuminated by searchlights. Members of the family said they could not see the definition of lights as it appears on the color negative.

Professional photographers conjectured the camera was able to pick up details the human eye was unable to see. Atmospheric conditions that night included a dull moon, with a clear sky and stars. In order to perform photo analysis and to determine the credibility of the photograph, Cliff King, photographer and John Gumm, chief photographer for *The Oklahoma Journal*, shot color pictures of airplanes, stars, etc. in an effort to duplicate the image in some way.

Both men are experienced, highly-skilled professional photographers. Gumm has served around the world and is known as an expert in his field. He reported that the Boy Scout camera used to shoot the picture has a fixed focus lens with a shutter speed of 1-50th of a second and a relative aperture of F:11. The film was Kodacolor X having a relative speed of ASA 64. The approximate focal length of the camera lens is 2½ inches or more technically, 60mm.

### ANALYSIS

Gumm said after examination, "this gives the object an arbitrary size of 50-foot diameter. Measuring the image size on the film (4.5mm) the object would have to have been less than a mile distance from the camera. Measuring the density of the film, the brightness of the object would be relatively twice that of the full moon."

Mr. King shot another roll of the same type color film, in the same camera, standing in Alan Smith's backyard, at approximately the same time of night. This was done to eliminate the possibility that Alan's camera had a flaw in it or a light reflection was being bounced off of some earthly object.

All tests proved fruitless. The airplane picture looks like airplane lights. The color negatives shot by Cliff King turned up with no image or reflection. There was no flaw in the camera that could be detected by the Oklahoma Journal photographers. The image on the negative is real, they concluded.

In addition to their own photo analysis, *The Oklahoma Journal* submitted one Kodacolor negative, an 8" x 10" color print and the news article from *The Oklahoma Journal* dated October 5, 1965 to Major Hector Quintanilla, Jr. TDEN/UFO. As head of Project Blue Book, Major Quintanilla assigned the project to the U.S.A.F. Photo Processing (DPP) and Photo Analysis (DPA) Divisions. In their Photo Analysis Report Number 66-21 dated 9 June 1966 (see copy included with this article), they noted

(continued next page)

PHOTO ANALYSIS REPORT NR 66-21

PAGE 1 OF 1 PAGES

DATE OF REPORT 9 June 1966

SUBJECT UNIDENTIFIED FLYING OBJECT

LOCATION TULSA, OKLAHOMA, USA

DATE 2 August 1965

PHOTOGRAPHY

AF \_\_\_\_\_ IR \_\_\_\_\_ QUALITY Good

P HRS One Kodacolor negative and one 8" x 10" color print.

News article "The Oklahoma Journal" 5 October 1965

1. PURPOSE: This report answers Work Order Number 66-43 submitted by Major H. Quintanilla, Jr., TDEM/UFO, requesting a photo analysis of an alleged unidentified flying object photographed at Tulsa, Oklahoma on 2 August 1965.

2. ANALYSIS: The following analysis represents a joint effort of the Photo Processing (DPP) and Photo Analysis (DPA) Divisions. Based upon the information furnished, we can neither confirm or deny the identification of an unidentified flying object. The somewhat oval-shaped, tri-colored object shown in the photograph is believed to be an object; however, the following comments are furnished as discussion. The object is quite clear with rather well-defined edges and clarity of detail. Measurement of image size on the negative resulted in a 2.5 mm size rather than the 4.5 mm stated in the news article. Using the 2.5 image size and the camera/range data quoted in the article, the object becomes approximately 30 feet in diameter - or some 40% smaller than quoted in the article - at a range of less than one mile. Some question arises however as to the accuracy of the range determination (camera to subject) at the time of day (0145) and under the conditions stated in the news article. Range is very difficult to determine at night and cannot usually be determined accurately even by experienced pilots. A further question is posed as to why some tonal difference in the sky was not recorded on the film in that atmospheric conditions on the night of 2 August 1965 were described as a dull moon with a clear sky and stars. Some tonal variations in a sky background are usually observed even on night photography. The only variation observed in this case was a line caused by a scratch on the film. Photo processing personnel noted that the image bears a resemblance, although doesn't appear identical, to the effect they have observed obtained by photographing a multi-colored revolving filter flood light of the type used to illuminate and color aluminum trees during the Christmas season.

PHOTO ANALYSIS BY:

*Larry L. Benson*

WILLIAM R. KINNEY  
Intelligence Research Specialist

APPROVED BY:

*Frank E. McPeak*  
RICHARD L. CHANCE  
Captain, USAF  
Chief, Photo Analysis Division

*Wilber Price, Jr.*  
WILBER PRICE, JR.  
Director, Photo Exploitation Directorate



ALAN SMITH, AGE 15

Walt Andrus

### PHOTO, Continued

measurement discrepancies in the image size and thus the calculations previously performed by John Gumm and Cliff King.

"Based upon the information furnished, we can neither confirm or deny the identification of an unidentified flying object" is quoted directly from the report to Project Blue Book. A closing comment was made that suggested an alternative object in the photograph -- "photo processing personnel noted that the image bears a resemblance, although doesn't appear identical, to the effect they have observed obtained by photographing a multi-colored revolving filter flood light of the type used to illuminate and color aluminum trees during the Christmas season."

This report is probably a typical example of the state-of-the-art of photo analysis by the U.S.A.F. in 1966. Computerized photo enhancement was later developed by scientists at Jet Propulsion Laboratories in Pasadena, California as a more refined tool for our space program. This process has been used successfully in the analysis of UFO photographs.

Alan, a newspaper carrier boy for the *Tulsa Tribune*, said he had paid little attention to flying saucer reports in the

past and had given only cursory attention to newspaper stories about them. The family is a typical middle-class group. They live in a modest home in the southwest part of Tulsa and were contacted by the *Oklahoma Journal* first.

### INTERVIEW

The author of this article was visiting in Tulsa, Oklahoma City, Okla. and Pampa, Texas during the August 1965 UFO "flap," however I was not fortunate enough to have had a personal sighting. I took advantage of the daily newspaper published reports in each of these cities to amass a file of sightings. At the same time the coverage on radio was quite extensive. I was not aware that Alan Smith had been able to photograph a UFO early in the morning of August 2, nor was he until several weeks later when enlargements were made of the color negative.

I personally conducted a taped interview with both Alan Smith and his father A.L. Smith in July 1966, when my family was again vacationing in Tulsa. A photograph is included in this article showing Alan holding a copy of *The Oklahoma Journal* that featured his photograph and sighting report. This copy of the newspaper is part of the

MUFON file on this unique case. It may be noted that the color UFO photograph, Alan's article and photograph shared space on the front page with the visit of Pope Paul VI to New York City. W.P. "Bill" Atkinson, the publisher of *The Oklahoma Journal* in Oklahoma City is responsible for recognizing this newsworthy subject, for conducting the investigation and the series of UFO sighting report articles, throughout Oklahoma, that followed in his newspaper.

### ANNIVERSARY

The twentieth anniversary of Alan's historic color UFO photo was observed by the *Tulsa World* on Sunday, August 4, 1985. The front page feature depicted a current photo of Alan holding the original copy of *The Oklahoma Journal* (now out of business) and his enlarged UFO photograph. Ralph W. Marler, staff writer and Jim Wolfe, photographer for the *Tulsa World* collaborated to produce an outstanding article commemorating this now famous event in UFO literature. Mr. Marler published a follow-up article the next day covering an interview with MUFON's International Director and the investigative activities of the Mutual UFO Network in Oklahoma, featuring Mrs. Jean Waller, State Director for Oklahoma and Dwight Dauben, Consultant.

The MUFON UFO Journal purchased the photograph from Jim Wolfe which adorns this month's front cover. (Since the Journal does not publish in color, the photo reproduction loses some of its significance.)

Since the credibility of the photographer of a UFO is more important than the photo itself when performing a preliminary investigation, these factors have been stressed in this article. Professionals will conduct the photo analysis for MUFON, however the individual Field Investigator must obtain the vital film and camera data, where the photo was made, the weather conditions, and foremost, a character check of the photographer

(continued on page 18)

# SECURITY POLICY

By Donald M. Ware

*Editor's Note: The author is a Lt. Colonel (Retired) U.S.A.F. He received a B.S. in Mechanical Engineering and a M.S. in Nuclear Engineering. Mr. Ware was a U.S.A.F. fighter pilot and a graduate of the Air War College. He became a MUFON State Section Director in 1982 and the State Director for Florida in 1984. This article is Mr. Ware's personal viewpoint on UFO secrecy.*

How many MUFON investigators have considered the government policy of secrecy on UFOs from the point of view of a high official responsible for the security and welfare of the nation? I think if we all did this we could learn to accept the policy as necessary, and we may even earn some cooperation with government agents in our common quest for knowledge.

## INTRODUCTION

Military pilots are debriefed by their intelligence officer after returning from each combat mission. By 1945 some agent in Washington had accumulated a number of detailed reports of Foo Fighters, from both combat theaters. In 1946 his office must have received reports from Sweden of objects with strange design and performance. This agency was concerned about Soviet expansionism and was very aware of the military impact of a technology breakthrough; i.e. radar, jet engines, and nuclear energy.

In July 1947, the Roswell incident occurred. People like Hoyt S. Vandenberg must have concluded then that some UFOs were spacecraft controlled by an advanced intelligence, if they had not already reached that conclusion. They would realize that if our adversaries acquired the technology represented by these vehicles before we did, our security would be severely threatened.

Information on such technology must receive the most extreme protection.

## AIR FORCE

Visits from aliens demonstrating advanced technology are a national and international problem rather than a military problem. A research program based on highly-classified hard evidence of advanced technology must be conducted by a small group of highly paid individuals willing to work in remote places and spend the rest of their career in that endeavor. But military people must change jobs frequently to get promoted, and are not suitable for that kind of program.

The researchers would want to gather additional information and material as it became available, but they were not listed in the phone book. Therefore, the U.S. Air Force was chosen as the organization to accept UFO reports. This led to projects Sign, Grudge and Bluebook. The Air Force role as the government's public relations agent was difficult, especially since they weren't the primary investigators of those cases that involved hard evidence or significant technical information. And most of them probably didn't even know it. Before long they were just carrying out the policy codified by the Robertson Panel in 1953, to keep the public from getting excited about UFOs.

Air Force efforts were criticized as grossly inadequate by many, but they were still serving a useful purpose. It wasn't until the mid-sixties that Air Force involvement became more of an embarrassment than a benefit, and the Condon report was used to get the military out of the public relations role.

## SECURITY POLICY

Concerning classified information, most of us are familiar with the "need-to-know" policy. Fewer understand the

different levels of compartmentalization this policy engendered. Even the President is not given information on some programs unless he is responsible for making decisions on that program. Presidents spend so much time talking to the press there is always the danger that classified words like "stealth" will be used.

However, the security system can work well. For example, the YF-12 was flight tested before it was publicly acknowledged. The reason it works is because, if you have a secret you really must keep, you don't admit you have a secret. That way the KGB doesn't know who to bribe.

## REACTION

So when the Air Force publicly gathered UFO information and photographs, etc., much of which seemed to disappear, and then claimed insufficient evidence of alien spacecraft, ufologists got upset. They don't like being lied to. But it wasn't against the law to lie. Some spokesman involved probably did not know the whole truth, and others recognized that national security was more important than their reputation among ufologists.

The ufologist may become frustrated, because he has worked long and hard to get information he knows the government has. This sometimes leads to antagonistic attitudes that don't do anybody any good. It is truly unfortunate that the government position contributed to some witnesses being adversely affected by their experience. What we need now is greater understanding and tolerance, so we can channel our efforts to more productive endeavors.

## FUTURE COOPERATION?

We should spend more time

*(continued on page 18)*

# PENN STATE SIGHTING

By Stan Gordon

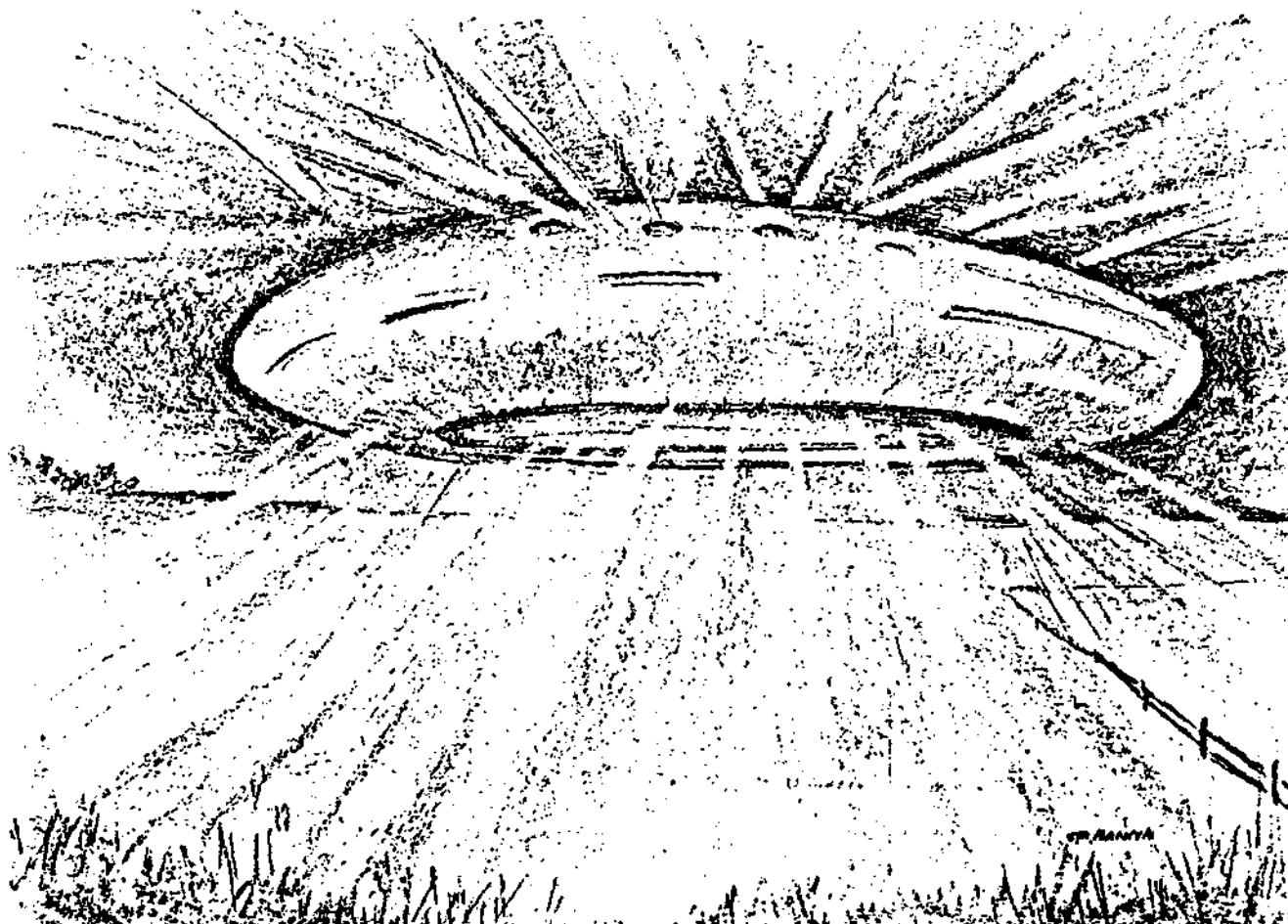

Recently the MUFON UFO Journal published several articles which have shown indication that unexplained UFO activity in some cases seems to occur at nearly the same time, and in the same general location where observers have reported the passage of a scientifically explainable UFO, such as a bright meteor or a satellite re-entry. This "covert" activity should be closely monitored by researchers to see if additional cases of this type are occurring.

A recent possible example of this type of activity occurred during the night of June 20th, and the early morning of June 21, 1985. It was almost midnight when 8 to 12 bright, reddish-orange lights with contrails following behind, moved in a V-formation from the NW. to the SW.

## HOTLINE

The objects moved very fast across the sky and were in view for only seconds. Many people were taking advantage of the beautiful summer weather, and so the witnesses were plentiful. The Pa. PASU UFO Hotline was jammed until 4 a.m. with calls from both professional and civilian observers who wanted to report their sighting as well as seek an explanation.

As we charted the location and the time of observations, it became apparent most reports could be explained. We put in a call to the Space Center division of NORAD, in Cheyenne Mountain, Colorado, to see if they had any space junk re-entry that could relate to our reports. They confirmed that at the time we received reports of the UFO formation, the Russian Satellite Cosmos 1530 had broken into several parts (about a dozen) when it re-entered the Earth's atmosphere over the Eastern section of

the United States.

As we continued to sift through the dozens of phoned-in sighting reports, we found that several observations did not fit in with the satellite re-entry. In the days to follow, other sightings of an unusual nature that occurred this same night would come to our attention.

## OTHER VIEWS

At 11:55 p.m. on June 20th, about 5 minutes before the satellite re-entry, we received an anonymous call from a man who stated that he and several friends near Bethel Park, a suburb of Pittsburgh, had observed a huge, elongated object with multiple blue and white lights, that moved slowly across the sky. It was so large as it passed over them, that it blocked out the sky and stars in that position.

(continued on next page)

## PENN UFO, Continued

At almost the same time, another witness at Castle Shannon, another nearby suburb, reported a close encounter. The woman was returning from the grocery store and was walking up the steps to her apartment building when she noticed lights moving slowly just above the roof of the building. As it moved overhead, she was awestruck by the sight of a huge, solid-appearing, oval-shaped object no more than 50 feet above the apartment building.

The gray object was estimated to be 300 feet long (the length of a football field) and was covered with many lights that were small in size and dim in brightness. Over the entire surface of the object, were structures that jutted out from the main body, and each structure had a dim light on the end of it. The witness had trouble trying to explain these protruberences, but she indicated that they were like individual compartments.

A low whirring sound could be heard as the object slowly moved out of sight toward the East. The object was under observation for several minutes. The next sighting was reported from Jefferson County which is about 90 miles North of Pittsburgh.

At approximately 3 minutes after midnight (June 21), two men were driving home on a back road when they observed a very large, glowing, white object about 100 feet above the ground. The object displayed six steady blue lights, and made no sound as it slowly moved ahead of the men who were about 150 feet away.

## STAR-BLIMP

At 12:15 a.m. near Champion, Somerset County, a carload of people returning to their homes from work, claimed to have seen a large round object with lights on it hover low off the ground, then ascend into the sky. But the most interesting sighting of this night occurred at 12:30 a.m. only 5 miles from this location, but in Fayette County. Mr. R. was about 2 miles West of Indianhead when he came over a hill and noticed a cluster of lights that at first he thought was bright stars. As he approached closer he realized that the

lights were attached to a large object that at first glance he thought was a blimp.

He continued up the road and turned around to take a better look at the object. The object was moving very slowly, and R. tried to flag down a car coming up fast, but it did not stop. The object was crossing the road, and was well over 100 feet long. R. got out of his car to take a better look. At this point the object was on the right side of the road. He yelled toward the object, still thinking it was some type of blimp or balloon. At this time the object began to emit bright blue lights from the bottom. The object was only about 30 feet above the trees and the lights illuminated the trees and the ground below.

## NO CAMERA

There was a trailer on the left side of the road, and the dogs there were barking excitedly. R. ran over to the trailer to ask the people to come out to see this object, and he hoped that they would have a camera. An elderly man came to the door and R. pointed the object out to him. The man said to R., "I never seen anything like that before," and told him he had no camera and went back into his residence!

The object at this time was moving slowly over the nearby field and R. ran towards it. He stood in the field looking directly up underneath the object trying to see some type of marking or insignia to better identify what he was seeing. After about 5 minutes he decided that he just had to get someone else to witness this, so he ran to his car and headed home where he awoke his parents, and took them back to the field. It took at least 10 minutes to get back to the site, but unfortunately the object was gone. On the way home to get his parents R. kept saying in his head, "I need a camera."

R. described the object he saw as elongated, like a blimp. It had a metallic-silver surface and was at least 100 feet long. There appeared to be 6 blue lights in the top section of the object and the entire top seemed to spin in a counter-clockwise motion. At times brilliant blue flashes of light would emit from the top of the object. The bottom of the object appeared to be hollow, judging

from the bright blue light it emitted. The object made no noise like an engine; what he heard was "like something enormous moving through the air."

R. had the object in view for about 20 minutes and is now baffled by what he saw. He realizes it could not have been a conventional blimp or balloon. Investigation continues into the sightings.

The data gathered so far indicates that possibly several UFOs were in the Pennsylvania skies this night. We would be interested to hear from other investigators who have sighting reports under study for this same date. (Correspondence may be sent to PASU, C/O Stan Gordon, Director, 6 Oakhill Avenue, Greensburg, Pa. 15601. The Pa. 24 hour UFO Hotline is 412-838-7768.

## UFO NEWSCLIPPING SERVICE

The UFO NEWSCLIPPING SERVICE will keep you informed of all the latest United States and World-Wide UFO activity, as it happens! Our service was started in 1969, at which time we contracted with a reputable international newspaper-clipping bureau to obtain for us, those hard to find UFO reports (i.e., little known photographic cases, close encounter and landing reports, occupant cases) and all other UFO reports, many of which are carried only in small town or foreign newspapers.

"Our UFO Newsclipping Service issues are 20-page monthly reports, reproduced by photo-offset, containing the latest United States and Canadian UFO newsclippings, with our foreign section carrying the latest British, Australian, New Zealand and other foreign press reports. Also included is a 3-5 page section of "Fortean" clippings (i.e. Bigfoot and other "monster" reports). Let us keep you informed of the latest happenings in the UFO and Fortean fields." For subscription information and sample pages from our service, write today to:

UFO NEWSCLIPPING SERVICE  
Route 1 -- Box 220  
Plumerville, Arkansas 72127

# THE BENTWATERS INCIDENT

By Ray Boeche

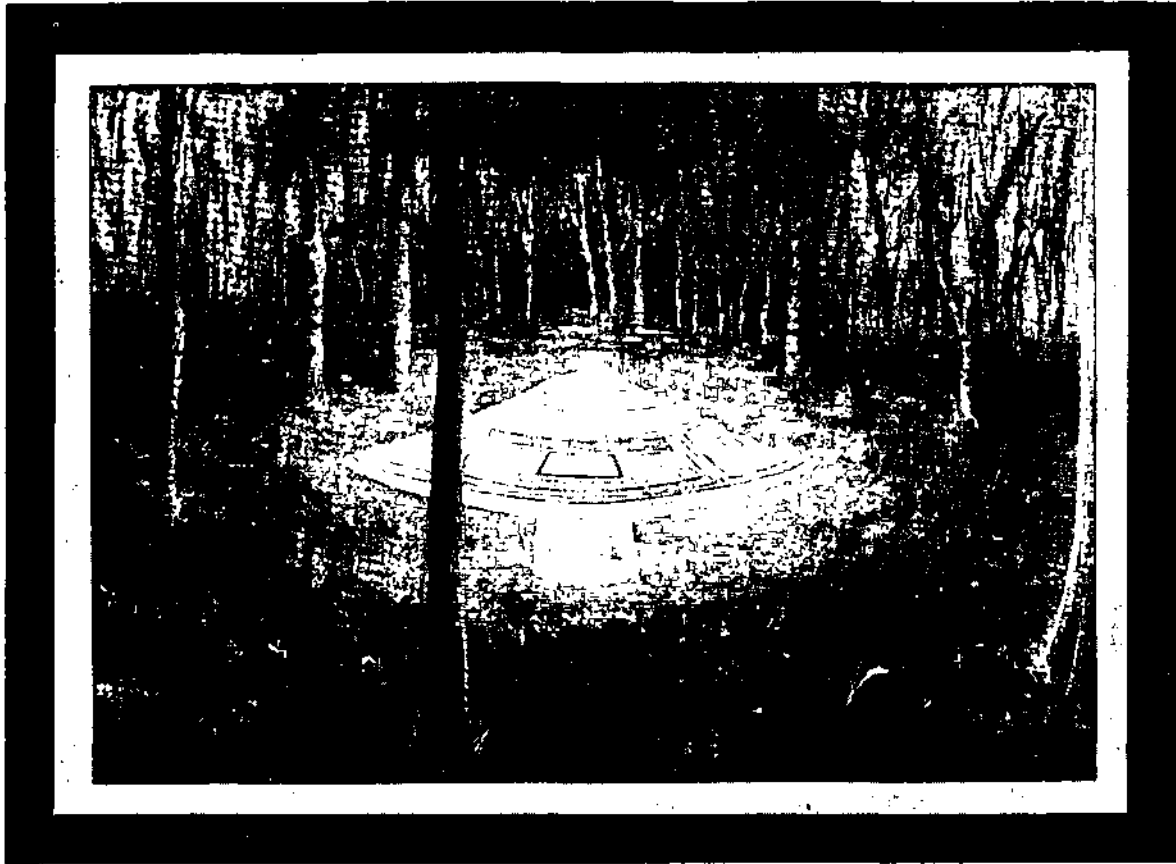

Illustration by Richard Cherry, England

In October of 1985, my wife Nancy and I spent several weeks traveling through England. One of the major purposes of this trip was to learn the current status of research on the Bentwaters Incident, from the perspective of the first investigators of the case. New information has been surfacing on this event, and the best way to clarify matters was a personal meeting with the British researchers.

## MEETING

I met with Jenny Randles and Dot Street (who along with Brenda Butler co-authored *Sky Crash*, an excellent early study of the case), on October 22, 23, and 24 in London. We had the opportunity to discuss the case at

length, and explore recent developments. While nothing has yet been forthcoming to resolve the many questions still surrounding the case, two very interesting new aspects have surfaced.

Jenny disclosed that she has been shown correspondence between Colonel Charles Halt (the author of the only official document concerning the incident to surface thus far) and a major British newspaper. The correspondence allegedly concerned Halt's efforts to sell his story of the events to this paper. The most significant aspect of this is an offer made by Halt to provide information which may very well lead to another *official* confirmation of the story.

According to Jenny, Halt

promised to furnish for the paper a copy of a memorandum from a superior officer at another American base in Britain, endorsing Halt to conduct an investigation on behalf of the United States Air Force.

This letter was, according to Jenny, in the private file of a reporter who was handling these "negotiations" for the paper. This reporter gave Jenny every indication that she could read this correspondence, but when she asked for a photocopy, he declined.

## MEMO

"There were about 8 or 9 points (outlining what Halt would provide the

*(continued next page)*



RAY BOECHE

## BENTWATERS, Continued

paper)," Jenny said, "but that was the most significant — the fact that Halt was prepared to supply documentation to prove that he had been endorsed by higher authority to carry out an official investigation into the case. This, of course is crucial to your Freedom of Information Act requests, because they're flatly denying it (the orders)."

I am currently awaiting a response to an FOIA request which I have filed with the base in question, asking for a copy of this order to investigate. I have also attempted to contact Col. Halt at his new duty station at Kunsan AFB, Korea, to attempt to get some type of comment from him, but have received no response so far. If copies of these orders can be secured through the Freedom of Information Act, it will be another significant step forward in locating other records which eyewitnesses say exist, such as photographs, movie film, etc.

Concerning Col. Halt's story for the newspaper don't hold your breath. One of the provisions Halt requested in the letter, was, according to Jenny, that if he provided the information to the paper, they would not be allowed to print it until his discharge from the Air Force. That of course, is a major stumbling block for the newspaper, and Jenny indicated that negotiations are

still ongoing.

On yet another front, Jenny Randles has been in contact with a scientist who has made a quite startling statement about the entire event. Dr. Allan Bond, a former British Ministry of Defence scientist, who still occasionally works under contract for the MOD, is an expert on rocket propulsion systems, including nuclear power systems for spacecraft. After reading Sky Crash, he became intrigued with the case, and contacted Jenny in November of 1984.

He made it clear to Jenny from the outset that he didn't necessarily believe in aliens, but he was willing to try and find out what might have happened. He believed there was another explanation for the events, and that the UFO aspect had been given as a means of covering it up. He indicated he would attempt to make some checks through sources available to him.

## NUCLEAR REACTOR?

Bond phoned Jenny again the next night, and indicated that he did indeed believe that there was something to the case. He seemed to feel, initially, that it may have been the recovery of a part of a satellite which used a nuclear reactor for a power source. He also indicated that he was intrigued with the Cash-Landrum case, which had occurred on

approximately the same date as the events at Bentwaters.

He indicated that if the information he had heard was correct, both the object at Bentwaters, and the Cash-Landrum object sounded exactly like a SNAP 10-A nuclear reactor. Bond described the SNAP 10-A as conical, about 2 meters by 3 meters. According to Jenny, he said, "I'm not very happy about getting involved in this, it's a very delicate thing, you know." He indicated he would have to be out of the country on business for a while, but would be in contact with Jenny again, as soon as he returned.

When Jenny was able to contact Dr. Bond some time later, he had no more comment to make concerning his satellite recovery theory. I asked Jenny about his response to her, and she replied, "He was very wary about saying anything. He said, 'Look, I don't really want to delve into this anymore. I've looked, and I'm sure there's something to it, but quite frankly, you're messing with something so serious here, that it is the kind of thing you could easily end up at the bottom of the Thames River for. My advise to you is to let it drop.'"

## THREAT

Dr. Bond indicated he would keep his ears open for any new information he might hear, but that he wasn't going to push too hard. He indicated it "isn't worth my job or my life." The last contact Jenny had with Bond was in June of 1985.

He indicated he had heard nothing new, but had found out from friends in the Ministry of Defence that when the story of the event appeared in the *News of the World* in October of 1983, "Boy, oh, boy, when that story went in the *News of the World* did you cause a few people trouble."

Unfortunately, we have no real clarification from Bond if what he discovered really did indicate recovery of a nuclear reactor from a satellite, or something else. I find it is extremely interesting that he would indicate that delving into what had occurred could prove to be a life-threatening

(continued on page 18)



**MINISTRY OF DEFENCE** Sec(AS)2a, Room 8245  
Main Building Whitehall London SW1A 2HB  
Telephone 01-218 (Direct Dialling)  
01-218 8000 (Switchboard)

J R Kyniston  
1831 S. E. Hawthorne Blvd  
Portland  
Oregon 97214  
Apt. 308  
USA

Your reference

Our reference

Date D/Sec (AS) 12/2/1  
28 June 1985

Dear Mr Kyniston

Thank you for your letter of 25 March 1985. You may find it useful if I explain that the sole interest of the United Kingdom Ministry of Defence in reported sightings of Unidentified Flying Objects (UFOs) is to establish whether they have any bearing on the defence of the country.

There is no organisation in the Ministry of Defence appointed solely for the purpose of studying reports of such objects, and no staff are employed on the subject full time. The reports we receive are referred to the staff in the Department who are responsible for the air defence of the United Kingdom, and they examine the reports as part of their normal duties.

Since our interest in UFOs is limited to possible defence implications we have not carried out a study into the scientific significance of these phenomena. Unless there are defence implications we do not attempt to identify sightings and we cannot inform observers of the probable identity of the object seen. The Department could not justify the expenditure of public funds on investigations which go beyond the pure defence interests.

We have to recognise that there are many strange things to be seen in the sky, but we believe there are adequate explanations for them. They may be satellite debris re-entering the earth atmosphere, ball lightning, unusual cloud formations, meteorological balloons, aircraft lights, aircraft at unusual angles or many other things.

The only information we have on the alleged "UFO sighting" at Rendlesham Forest in December 1980 is the report by Colonel Charles Halt, of the United States Air Force. We are satisfied that the events described are of no defence significance. I can assure you that there is no question of attempting to cover up any incident or mishap, nor are we attempting in any way to obscure the truth. I enclose a copy of Colonel Halt's report which may be of interest.

I attach copies of two recent Parliamentary Questions on the Ministry of Defence's interest in UFO reports, which you may be interested in.

Yours sincerely

P M HUCKER

# MUTE EVIDENCE REVISITED

By Richard D. Seifried

In the May, 1985 issue of the "MUFON UFO Journal," Robert Wanderer gave an excellent review of Daniel Kagan and Ian Summers' book, *Mute Evidence*. The response I expected did not appear in the following editions of the MUFON UFO Journal. Just as I did in a CUFOS publication I feel obligated to submit a rebuttal.

After searching about for several weeks trying to find where I had placed *Mute Evidence*, I found it jammed behind other paperbacks. The first time I read it I was somewhat angry with the authors; so much so that I did not read the final chapter. That was a mistake. In reviewing the book a second time I realize that I was also quite unfair to Kagan and Summers.

Most of my objection to the paperback was what I considered to be closed-mindedness on the part of the authors. They did not keep an open, scientific attitude. I suspected that they had a pre-conceived conclusion in mind when they began writing. Yet, I had reacted in the same biased manner toward *Mute Evidence*.

## OBJECTIONS

My basic objections are two in number. I take exception to some of the statements made in the book and secondly, personal experiences will not permit me to totally accept what the book presents. In particular, I do not like how some people are, I think, unfairly treated.

During the summer months I work in Montana. In 1980 I was fortunate to meet with Roberta Donovan, co-author of *Mystery Stalks the Prairie*. Ms. Donovan and I sat at a kitchen table in her relative's house in Missoula, Montana, and for perhaps two hours we shared ideas and experiences dealing with UFOs. She is a free-lance writer who depends on her writing for a livelihood.

I was told how the publishing

agreement for *Mystery Stalks the Prairie* was a disappointment with very limited distribution. She explained how, almost overnight, all of her contacts were cut off. Keith Wolverton, her co-author, said he had been silenced and would lose his job if he made further comments about UFOs or cattle mutilations. It was apparent to me that Ms. Donovan was frustrated. An investigation was incomplete and she was unable to continue it.

Ms. Donovan is a very nice lady. I wish Kagan and Summers had met with her.

Although Montana is a great land geographically it is small socially. Everyone seems to know everyone else. Since 1980 I have met several people who know Keith Wolverton personally as well as other members of the Cascade Sheriff's Department. All have reported that the officers are very kind, intelligent, and well-trained professionals.

Referring to *Mystery Stalks the Prairie*, (page 188, *Mute Evidence*) reads "...which contained a sensationalized account of these cases." This quote was identified as part of *The Rommel Report* which was analyzed by the authors.

On page 190 Kagan and Summers reported, "The book (*Mystery Stalks the Prairie*) had been published by a mysterious organization in Montana called the THAR Institute."

"Sensationalized accounts... Mysterious organization." The implications are apparent. *Mystery Stalks the Prairie* is discredited without interviewing one of the two authors who wrote the book.

## BUFFS

Although the authors admitted that UFOs had been reported over the missile sites in Montana, very little positive or unbiased words about UFO investigators can be found in *Mute*

*Evidence*. Terms such as "...the entire UFO subculture (ref. p. 106)," "...UFO buffs...(ref. p. 169)," and various comments on pages 308-309 are examples of the authors' opinions of those of us who believe in UFOs.

They use literary space to describe the mystery helicopter craft, hypnotic regression, and related topics yet they reject said phenomena. On page 487, Kagan and Summers began their summary, Chapter V. The second paragraph exemplifies their attitude toward UFO research. "This was the same climate (that the mutilation problem developed in) in which the pseudoscientific teachings of the UFO establishment had been flourishing for decades."

## PHANTOMS

This sentence contains what concerns me most. If we accept *Mute Evidence* as the final word in cattle mutilations, then in all fairness, treating all things as equal, UFOs do not exist and citizens like Walt Andrus, Dr. Hynek, you and I are floundering about, playing games with reality, pursuing phantoms which do not exist.

My displeasure of the injustice grows as I write this. My notes tell me that other assumptions are not true. Kagan and Summers are not fair to two groups of individuals in particular. One group is the law enforcement officials. I think the authors try to be fair but just don't quite make it.

The law officers in Montana, for example, impress me with their intelligence and training. The ones I have met and talked with are surprisingly kind gentlemen who grew up in the country they protect. They are big-game hunters and fishermen. They have spent a lifetime in the out-of-doors and know how to read signs, be they a spoor of an animal, a broken blade of

(continued next page)

## EVIDENCE, continued

grass, or a wing-flutter imprinted in the snow. They have seen many dead animals, including livestock in various stages of decay. These lawmen recognize the ravages caused by predators.

Yet, if we take *Mute Evidence* to be gospel, these law officers almost to a man, have been duped into believing in a farce called "cattle mutilations." They all, for some reason, eagerly accept untruths and see evidence through clouded eyes because they so eagerly want to believe in cattle mutilations.

## VETS

Veterinarians are also abused. The reader learns that veterinarians are ignorant of conditions of normal deaths and resulting predation.

Kagan and Summers report, "Board-certified pathologists are as far away from the average clinical veterinary practitioner as a Sherlock Holmes would be from the cop on the beat in a small town...(ref. p. 187)." Again there is a derogatory statement against law officers. The implication is that "big city police" are superior in deductive techniques. Is this really true?

Veterinarians who deal exclusively with pet poodles and cats very likely do not have much expertise in the pathological analysis of large animal remains. However, the veterinarians involved in most mutilation cases are men and women who work out in the hills and on the open range. They see hundreds of dead animals and make determinations on causes of death. It is not new to them. They are not individuals who sit in a sterile animal hospital waiting to remove porcupine quills from some hapless canine.

Kagan and Summers did put Leland Gade of the "Montana Farmer-Stockman" newspaper in the right perspective. Not only did Gade attack the cattle mutilation investigators in 1975 but he also wrote a vitriolic editorial chastizing Captain Wolverton, of the Cascade Sheriff's Office, in a follow-up article published on August 6, 1981.

Cade must have made Kagan and



— Photo by  
Wendy Smath

Summers wonder, "Where is this guy coming from? What are his motives? Who is behind him? Are his literary attacks politically, economically, or socially motivated? Are they the result of his own belief that cattle mutilations are simply bunk?"

Chapter V, I think, detracts from an otherwise thought-provoking, well-written book. Page 494 contains their conclusive analysis:

"Myths like the cattle mutilation phenomenon are functional mirrors of the concerns of the citizens of a given society at a specific time, and tend to arise during periods of external tension and doubt."

## SOCIAL STRESS

Examples given of distress-causing influences include Nixon, Vietnam, Love Canal, Nukes, Inflation, and the Arab Oil Embargo. I can't argue with the fact that such problems overwhelm our senses with futility. However, think back, you older readers, to other supposedly happier, less tense times: World War I. The horrible influenza epidemic of 1918. The Great Depression. World War II.

No great explosion of UFO sightings occurred in those days. Cattle mutilations were not in the news. True, in WW-II we did have "Foo Fighters," little glowing balls of light that harassed our military aircraft. What was to

become known as UFOs were beginning to appear in Europe.

Kenneth Arnold's famous sighting occurred in 1947, a time of optimism, social stability, a decade of Big Band music, private home-buying on an unprecedented scale, and for the first time higher education for almost anyone who wanted it. Yet Arnold saw strange silver discs in the sky.

Does wishful thinking or social anxiety cause radar to track objects across the North American continent at remarkable velocities?

What overwhelming social or political event caused a New Guinea church congregation to see a UFO, with "aliens" waving down to them?

What about UFOs over our Minute Man silos? Hallucinations? Were they a result of military anxiety and misinterpretation brought about by environmental pollution and Watergate?

Kagan and Summers' Chapter V, "Invisible Geography," simply does not hold up under careful scrutiny and analysis.

Read *Mute Evidence* if you haven't, but please keep an open mind and an investigative, scientific attitude. Kagan and Summers did separate some considerable untruths, hoaxes and misinterpretation from fact. We should be grateful for their contribution to our understanding of a complex mystery.

# INVISIBLE UFO

By Francis Ridge

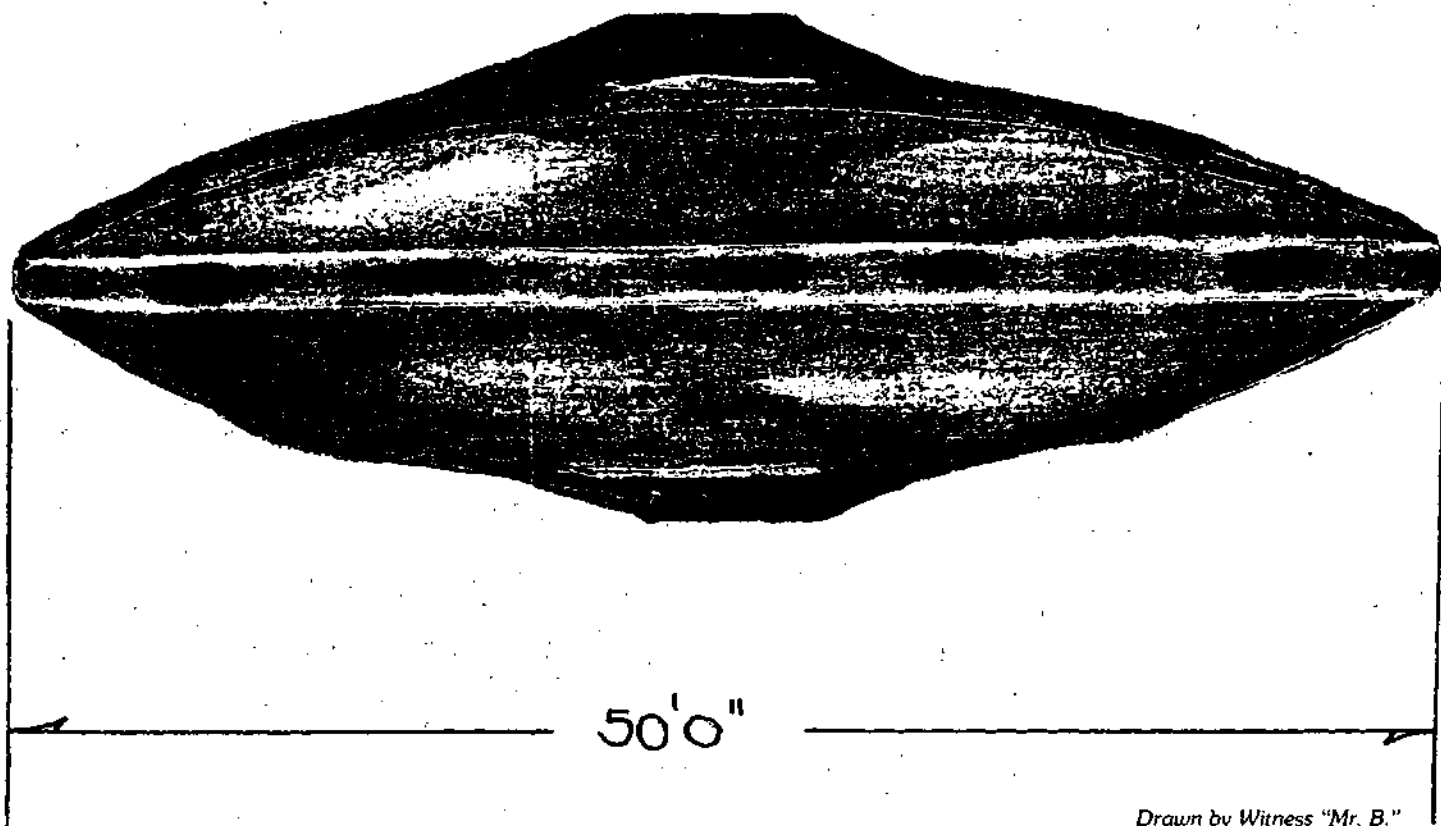

*Drawn by Witness "Mr. B."*

## BACKGROUND

Mr. B (30) and his male companion, Mr. R (31), were hunting for Indian artifacts on a cool clear day in November (established as the 17th). It was a Saturday and they had begun early, approximately 11:30 that morning. The area in question is the Wabash River bottoms near Savah, a farming community (very small) near Mt. Vernon, IN to the NW. The event area was 7.5 miles NW of Mt. Vernon and about 20 miles West of Evansville. Across the river to the West is Illinois.

## SIGHTING

At approximately 2:10 PM the men heard a rhythmic buzzing sound (similar

to a motor boat) and saw an object coming down the river low on the horizon. The object was disc-shaped, greyish-silver (mirrorlike) in appearance, moved fast toward them as it appeared to notice them, stopped overhead for 30-seconds, then departed.

Originally, the observer stated the object came from the North going South down the river, saw them, turned East and headed fast toward them. They were approximately 200 yards from the river and in a 500-acre-plowed field.

The topo map supplied by the prime witness (amateur archaeologist) gave us a corrected view. The actual path of the UFO was NW to SE, then NE, then headed NW. See drawing of UFO and topo map.

The elevation of the object was described as low at first on horizon dropping to 10' overhead, then on departure the elevation increased to about 22 degrees or one-fourth the way up on the horizon. The object, described as "big as a house," "30' wide" (drawing suggests 50'), became invisible when overhead, only casting a shadow on the ground. During the 30-seconds overhead the witnesses described the feeling of static electricity; their hair stood on end. The buzzing (pulsing about 2X's per second) was still heard when the object was overhead.

The witnesses tried to move out from under it, but were not able. The object was not seen to move away on

*(continued on page 18)*

# A UNIQUE CATALOG

By Dr. Willy Smith

## DEFINITION

UNICAT is a sophisticated data base embodying information on UFO sightings, conceived and implemented according to the following directives:

A) The data base contains only high-quality cases, where IFOs and questionable material have been eliminated as much as possible. The data base will be universal (hence the name: UNiversal CATalog) i.e., efforts will be made to include cases from as many countries as feasible.

B) The data base will be accessible to all those investigators that have actively cooperated in its creation. It will also be accessible to others and to the general public for a nominal charge.

C) UNICAT is essentially different from other computerized listings of UFO sightings inasmuch as information on a given case will be continuously added if available. Most computer catalogs — including UFOCAT — terminate the input of information as soon as the entry is completed. On the contrary, UNICAT is dynamic, and the software contains several programs for checking the data base integrity and for finding errors, including typing mistakes.

D) The design of UNICAT is such that it allows the retrieval of information in a very large number of ways, including correlations, sortings and even short narratives containing key words for each individual case. The computer output is immediate, directly readable and DOES NOT require a code book.

E) A special section will provide the references for each entry in detail.

## CRITERIA

The criteria that a case must meet to be entered in UNICAT are naturally rather stringent, and are summarized as follows:



DR. WILLY SMITH

-Dennis Stacy

1) At least two witnesses. However, a well-investigated case resting on the testimony of a single unimpeachable witness could be occasionally included.

2) Cases that have been well investigated by known ufologists, preferably those that have been published in the literature in any language.

3) Unpublished cases, or cases investigated by not so well known researchers will be acceptable only if there is a written report accessible to the organizers of UNICAT, and if the initial investigators are willing to provide additional information if requested.

4) The case should contain at least 10 of the parameters or characteristics specified by Dr. Hynek's list. We expect this list to change with time as cases are added to the data base and the truly significant parameters become evident.

## PURPOSE

The overall purpose of UNICAT, besides providing a reliable research tool for all investigators, is to prove by a direct application of the scientific method that UFOs are indeed a new phenomenon, deserving the attention of established science. The progress in the precise determination of the pertinent parameters will lead to a model, or profile, for the UFO phenomenon, furnishing not only an operational definition of it, but also determining the basic paradigm that any science must possess.

**MUFON**

103 OLDTOWNE RD.  
SEGUIN, TX 78155

# In Others' Words

By Lucius Farish

The **NATIONAL ENQUIRER** for October 29 carries a report by Henry Gris, stating that a fleet of seven UFOs were observed over the city of Kiev, USSR on May 26, 1985. A Soviet jet fighter, dispatched on an intercept mission, suffered engine failure upon nearing the UFOs. The pilot ejected as the plane spiraled downward and crashed.

The October issue of **OMNI** reviews Betty Hill's story of her 1961 UFO abduction and subsequent UFO experiences in the Anit-Matter/UFO Update section of the magazine. **JOURNAL** editor Dennis Stacy contributes an article on the financial perils of UFO research in **OMNI**'s November issue.

A fascinating-if-true story of a cattle-killing UFO can be found in the November issue of **FATE**. The report

alleges that a large disc-shaped UFO was seen at close range on a Missouri farm in August, 1896. When the UFO departed, three steers, their bodies completely drained of blood, were found in a patch of burned grass. Several other such incidents are claimed to have occurred in the state at the same time although preliminary newspaper research has failed to substantiate this claim. The same issue of **FATE** also contains Part 2 of Hilary Evans' article on "balls of light."

Bob Girard of Arcturus Book Service has recently published a small booklet detailing his own thoughts on UFOs and the human race's place in the cosmic scheme of things (perhaps with an emphasis on "scheme"). Is "the entire human life cycle...subordinated to the needs of an unperceived macrospecies"? Is there some sort of

conspiracy to "keep us human," as Girard speculates? This is all quite interesting food for thought, even if nothing can be proven, pro or con. In the final chapter of his booklet, Girard makes some very telling points, reminding us of the insanities we take for granted in our "normal" lives. As he says, the "true human" strives to leave the herd and to experience life from a "cosmic perspective."

Agreement with all of Girard's premises is not necessary in order to enjoy reading **THE COSMIC SHEEPDOG**. It will give you something (else) to think about, at the least. Copies are available for \$5.95 (plus 85¢ postage & handling) from Arcturus Book Service - P.O. Box 2213, Scotia, NY 12302.

---

## LETTERS

### OPEN LETTER

Dear Jenny Randles:

I just finished reading your last exchange with Ian Ridpath in the September, 1985, issue of the **MUFON UFO Journal**, and I feel compelled to ask you to refrain from pursuing this matter any further.

There is no purpose in attempting to have a rational and logical discussion of issues with Mr. Ridpath, as his interest does not lie in finding the truth, but in creating as much controversy and confusion as possible. Like other pseudo-debunkers, he uses whatever information he can think of, banking on the ignorance of the public, which cannot distinguish between milliroentgens per hour and

milliroentgens, and finds nothing suspicious if Venus is in the sky after midnight. He operates by innuendo, changing even the dates of events ("clearly in error") to suit his purposes, ignoring the data that demonstrates the lack of substance of his ideas.

It is a waste of time to reply to his letters and to the specious arguments put forward in his papers, as this will only provide him with new material to harp on. Like all the other members of the CSICOP club, he will never answer a point directly but will labor around it to fire the argument; and under no circumstances will he admit to having been wrong, even if he has to fib a little — to put it nicely.

So, Jenny, I strongly suggest that you ignore his barbs and use your

valuable time for your UFO research. Mr. Ridpath and his fellow club members will get what is due them without any help, as has already happened in the cases of the "Mars connection" and the "flying fishing boat" of New Zealand fame. It is bound to happen to Mr. Ridpath also, unless he sees the light — which I doubt — and realizes that one does not investigate a UFO report by visiting the place years later to play tricks with a TV camera, by not talking to the witnesses and by ignoring all significant information.

Sincerely,  
**Dr. Willy Smith**  
CUFOS, UNICAT  
Project

## PHOTO, Continued

with friends, relatives, minister of his/her church, and teachers if applicable. (Deliberate hoaxes have been disclosed by Field Investigators when following these procedures.)

A few teenagers have the misconception that they can sell UFO photographs to publishers for exorbitant amounts of money, therefore they try to hoax photographs. A trained Field Investigator can puncture their balloon at the source. Preferably, the photographs should be mailed to MUFON headquarters for analysis along with the prescribed data.

## PAYMENT

Alan R. Smith was 14 years old when he obtained the first known UFO night time color photo. It was investigated and analyzed as related in this article and copyrighted by *The Oklahoma Journal*. As an example, Alan's photo has been published worldwide in magazines. The most he has ever received is \$200 by *LOOK* and *LIFE* Magazine in the United States, and *PIX* in France for reprint rights. His father wisely deposited these checks in a Tulsa bank for Alan's education. The photo made him enough (approximately \$500) to pay three semesters of tuition to Northeastern State University at Tahlequah, Okla. and later the University of Tulsa.

The press attention to this photo amazed him and led directly to his decision to include journalism in his education. Today, Alan handles public information and marketing for the High Plains Vo-Tech school in Woodward, Okla. and free-lances some for area newspapers. He is now completing work on his master's degree in education from Northeastern State University. Alan and his wife Jamie have three children, Amos, 12, Glory, 10, and Eli, 8.

In conclusion, Alan had these comments for *Tulsa World* staff writer, Ralph Marler relating to UFOs. "The only serious thought I ever had was it was some type of experimental aircraft. The fact it's from this planet has more certainty for me than anything else. When you get down to it,

many people have seen a UFO. I feel many can be explained. I haven't seen one since."

## SECURITY, Continued

getting information from UFO witnesses and less seeking information from government agencies. Because of the strict policy of secrecy, our government is handicapped in investigating cases requiring much personal contact, such as abduction cases and those involving physiological/psychological effects. It is difficult to ask an abductee to submit to hypnosis while denying knowledge of alien presence. So, government agents depend on civilian ufologists to do this for them.

Dr. Niemtow's medical data bank seems to be a superb effort that could benefit us all. It could shed light on alien actions and on the dangers of proximity to some UFOs. Consideration of information from abductees for possible technical applications, such as the VISIT group has done, also seems like a good idea. However, we may be "stabbing in the dark" unless we get guidance by someone who knows more about alien technology than the open literature provides.

I would like to see more scientists use UFO reports in brainstorming activities related to future technology in their specialized fields. Maybe, if we develop a less antagonistic attitude toward the government policy on UFOs, government agents could find a way to foster such efforts and to guide our investigations toward the most promising cases.

## BENTWATERS, Continued

experience. We are still left with no definitive answers, only more questions.

Because of the confusing nature of this case, and because of lack of space for a full explanation here in the *MUFON UFO Journal*, it is impossible to delve into any of the other aspects of the investigation. I will, however, give a full examination of the events to date, in

my paper to be presented at the MUFON 1986 UFO Symposium in June.

The important thing to remember, however, is that the case is by no means solved, nor is it even fully investigated. It is, however, an ongoing, active investigation. New avenues of information are opening constantly—hopefully they will all finally converge on the truth.

## INVISIBLE, Continued

the NE "leg"; it was still invisible. It appeared in the NE scaring some crows before it headed back the way it came (NW or NNW). The men stayed in the area less than ½ hour and headed back to Mt. Vernon, which is about a 20-30 minute casual drive out of the bottoms. They arrived at 5:30 PM with a missing time of approximately 2½ hours.

The prime witness has had reoccurring nightmares of being taken "up into a dark area" and being confined "in a glass container." The experience didn't scare him, but his buddy was very upset about it.

Editor's Note: *This is phase I of the report. Subsequent articles will cover Mr. R's report, the on-site inspection with photographs and the final hypnotic regression of the two witnesses to reconstruct their 2½ hours of "Missing Time".*

— MUFON —  
AMATEUR  
RADIO  
NET

EVERY SATURDAY  
MORNING  
AT 0800 EST (OR DST)  
ON 7237 KHz S.S.B.

## MESSAGE, Continued

volunteered to be a Consultant in Veterinary Medicine as well as his prime interest in obtaining documents under the Freedoms of Information Act. He has been working with **Tom Adams** on cattle mutilations.

★ ★ ★

The theme of the Seventeenth Annual MUFON UFO Symposium to be held June 27, 28, and 29, 1986 at Michigan State University is "UFOs: Beyond the Mainstream of Science." Speakers scheduled are **John F. Schuessler**, Aerospace Engineering Executive; **Alan Holt**, NASA physicist on the Space Station Project; **Harley Rutledge**, Ph.D., Chairman of the Physics Dept., Southeast Missouri State University; **Bruce Maccabee**, Ph.D., physicist for the U.S. Navy Surface Weapons Center; **Michael D. Swords**, Ph.D., Science Professor at Western Michigan University; **David M. Jacobs**, Ph.D., History Professor, Temple University; and **Robert Bletchman**, Practicing Attorney, Manchester, Conn.

★ ★ ★

The "Second National UFO Information Week" will be observed August 10 through 17, 1986. The October 1985 issue of the Journal illustrated some of the ideas that were utilized throughout the Nation as suggestions to State and local groups for 1986 planning. Mrs. **Cynthia Hind** inaugurated the program on a worldwide scale by conducting programs in Harare, Zimbabwe, Africa. Mrs. **Marge Christensen** must be congratulated and commended for initiating this public education and information program as MUFON's Public Relations Director.

★ ★ ★

The 1986 Massachusetts MUFON UFO Forum is now planned for August 9 and 10 at the Beverly Golf and Tennis Club. The following are confirmed speakers: **Bud Hopkins**, **Dan Wright** and **Marge Christensen**.

★ ★ ★

In order to give public recognition and acknowledgement to individuals who have made outstanding contributions to the field of Ufology during the past year, the P.I.P.E.

Committee is establishing an annual award to be presented at the Annual MUFON UFO Symposium to the person nominated and selected by a popular vote ballot in the MUFON UFO Journal. The award plaque will represent the most outstanding contribution to the field of Ufology in the calendar year from June 30, 1985 to the date that the ballot appears in the Journal, which should be March, 1986.

The recipient need not be a MUFON member in order to be given the award. It has been suggested that we honor Dr. **J. Allen Hynek** by naming the award, **THE J. ALLEN HYNEK AWARD FOR OUTSTANDING WORK IN THE FIELD OF UFOLOGY**. The list of candidates will be nominated by the members of the P.I.P.E. Committee. The award

may be for an individual's contribution in any of the following areas: Research (in any aspect of the subject or into government documents), Investigation (outstanding performance for a particular case or series of related cases), and Public Education or Public Relations.

The above award will be entirely independent of the annual dedication of the MUFON UFO Symposium Proceedings, which is determined by the selection committee of the MUFON Board of Directors. Each year the Proceedings are dedicated to the person who has made the most outstanding contribution to the Mutual UFO Network, Inc. (MUFON) during the past years in advancing the scientific study of the UFO phenomenon.

Lawrence Fawcett and Barry J. Greenwood

# CLEAR INTENT



## THE GOVERNMENT COVERUP OF THE UFO EXPERIENCE

### What does the government know about UFOs and why won't it tell us?

With a foreword by Dr. J. Allen Hynek

# DIRECTOR'S MESSAGE

by  
Walt Andrus

In the November issue of the Journal, members were advised that a letter and ballot had been mailed to the MUFON Board of Directors on October 7, 1985 to solicit their ideas, recommendations and suggestions on improving the format, contents, style and professional caliber of the MUFON UFO JOURNAL. It was also emphasized that in spite of increased publishing and mailing costs due to inflation over the past 5 years, the annual membership/subscription dues to the Mutual UFO Network have not been increased since July 1980.

The MUFON annual financial report was included with the letter and ballot to Board Members clearly delineating that MUFON could not have financially survived if it was entirely dependent upon the income from the membership/subscription dues. Recognizing that the Journal is the major monthly communication media for our members and readers, it is imperative that the dues structure cover the cost of editing, publishing and mailing your magazine. Profit from the sales of the symposium proceedings could thus be earmarked for capital equipment expenditures (a computer), research and investigations, public education and fixed overhead costs. As a voluntary, not-for-profit, and tax exempt organization, the only salaries paid are to a part-time office secretary and a part-time clerk.

The ballot to the Board of Directors consisted of 5 basic questions: (1) Should the Journal accept and publish reputable advertising? (2) Should the Journal retain the present paper stock or utilize magazine stock (slick paper)? (3) Do you feel that the Editor should receive a monthly stipend? (4) If adequate material was available, how many pages should the monthly Journal contain? and (5) Taking into consideration your answers to the above questions, what price do you recommend for the annual

membership/subscription dues? Space was allocated for comments and suggestions on the ballot.

Since the Mutual UFO Network is governed by a Board of Directors of 17 men and women, their decisions on such matters as the annual membership/subscription dues must prevail. A tabulation of their ballots on the 5 basic questions is as follows: (1) A split decision existed on advertising in the Journal, (2) The present paper stock shall be continued, (3) It was nearly unanimous that the Editor should receive a monthly stipend for his/her services, (4) If adequate material was available, the majority favored increasing the Journal from 20 to 24 pages, and (5) A significant number recommended increasing the annual membership/subscription dues to \$25. (Others suggested \$20 to 30.)

Based upon the decision of the Board of Directors, the annual membership/subscription dues will be increased to \$25 in the United States and a single copy will cost \$2.50. Second class mailing to all foreign countries will become \$30 in U.S. funds, paid by International Postal Money Order or a check written against a U.S. bank. The special student membership has been eliminated. Since the study of the UFO phenomenon is frequently a family affair, additional members in the same family, that is identical home addresses, may become members for \$10 each when one member in the family subscribes at the regular rate, provided they so designate when submitting their dues. These adjusted prices or dues are effective February 1, 1986.

\* \* \*

It is quite conceivable that there will be a few members who object to the dues increase, since they have been the recipients for the past 5 years of the only monthly UFO magazine in the World selling at such a ridiculously low price. Even with the annual dues increase to \$25, each member will be

receiving twelve monthly issues as compared to other leading UFO magazines that publish only 6 issues per year for \$25 or more. As the World's finest monthly UFO magazine, the MUFON UFO Journal is still the ultimate bargain in UFO literature.

As announced in the November issue of the Journal, the Center for UFO Studies discontinued their eight page bi-monthly publication, the *CUFOS Associate Newsletter* with the June-July 1985 issue, edited by John P. Timmerman. It will be combined with their bi-monthly *International UFO Reporter* by adding 4 pages to the *IUR* and increasing the price for six issues per year to \$25 in the U.S.A.

Since the *International UFO Reporter* and the *MUFON UFO Journal* are the only two UFO organizational magazines still being published in the United States, it is imperative that both revise their financial positions for the future so they will not suffer the fate of the publications of NICAP, APRO and SBI.

\* \* \*

**David A. Bodner**, a member since 1975 has been promoted from a State Section Director to State Director for West Virginia, replacing **Theodore Spickler** who asked to be relieved of this responsibility due to occupational commitments. Mr. Bodner will be seeking a replacement for the southern counties of West Virginia. Mr. Spickler, who is still active, has been invited to become the State Section Director for the four northern West Virginia counties where he resides.

**James R. Melescuic**, State Director for Massachusetts, has appointed **Joseph Nyman**, a Field Investigator since 1976, to the position of State Section Director for Norfolk County. Joe has a B.A. in Mathematics and is a computer programmer. **Stan Smith**, D.V.M., living in Honolulu, has

(continued on page 19)

# MUFON UFO JOURNAL

NUMBER 201

JANUARY 1985

Founded 1967

OFFICIAL PUBLICATION OF



MUTUAL UFO NETWORK, INC.

\$1.50

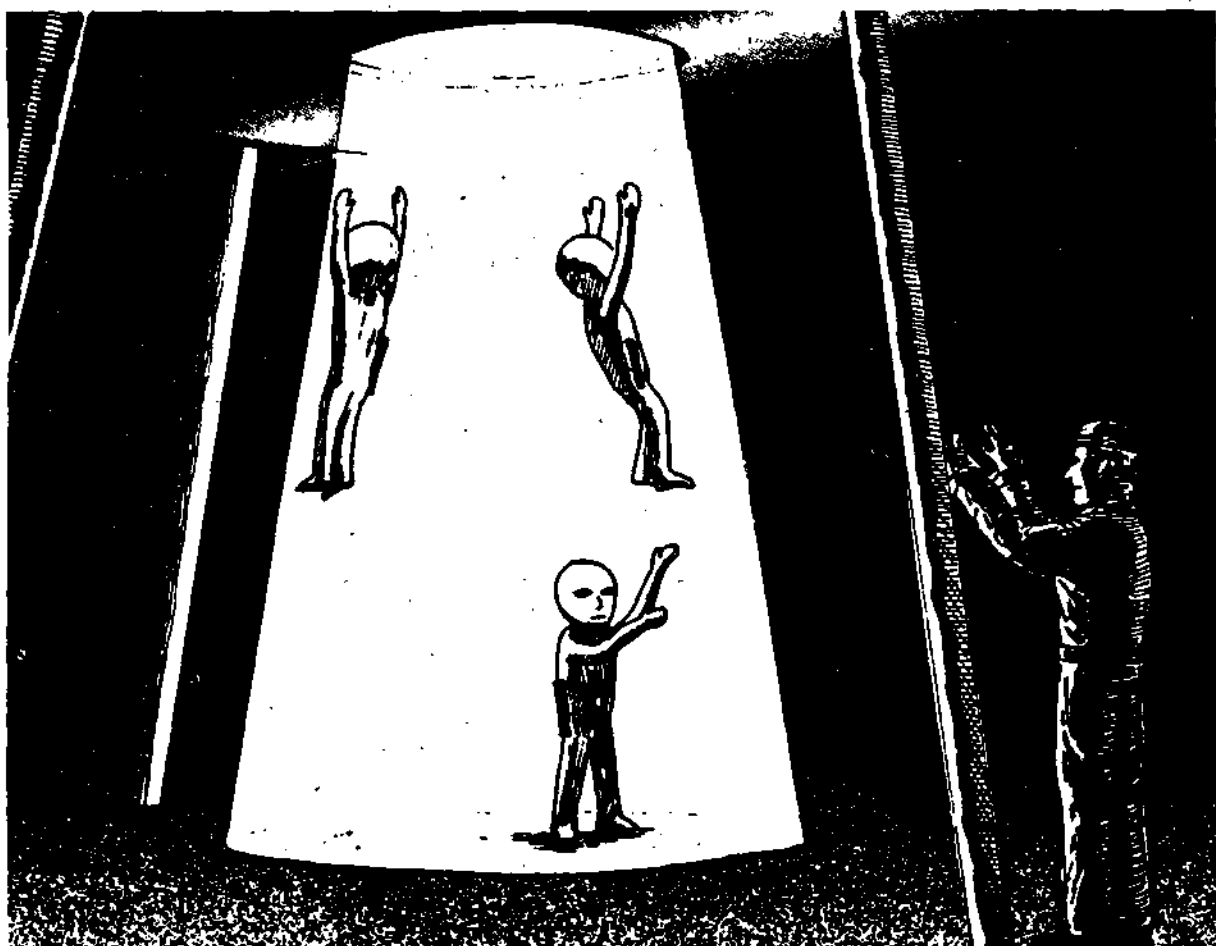

*The American serviceman's view of the alien contact with the base commander.*

## RENDLESHAM FOREST AFFAIR

**MUFON UFO JOURNAL**  
 (USPS 002-970)  
 (ISSN 0270-6822)  
 103 Oldtowne Rd.  
 Seguin, Texas 78155-4099

**DENNIS W. STACY**  
 Editor

**WALTER H. ANDRUS, JR.**  
 International Director and  
 Associate Editor

**THOMAS P. DEULEY**  
 Art Director

**MILDRED BIESELE**  
 Contributing Editor

**ANN DRUFFEL**  
 Contributing Editor

**TED BLOECHER**  
**DAVE WEBB**  
 Co-Chairmen,  
 Humanoid Study Group

**PAUL CERNY**  
 Promotion/Publicity

**MARGE CHRISTENSEN**  
 Public Relations

**REV. BARRY DOWNING**  
 Religion and UFOs

**LUCIUS FARISH**  
 Books/Periodicals/History

**ROSETTA HOLMES**  
 Promotion/Publicity

**GREG LONG**  
 Staff Writer

**SIMONE MENDEZ**  
 Staff Artist

**TED PHILLIPS**  
 Landing Trace Cases

**JOHN F. SCHUESSLER**  
 Medical Cases

**LEONARD STRINGFIELD**  
 UFO Crash/Retrieval

**WALTER N. WEBB**  
 Astronomy

**NORMA E. SHORT**  
**DWIGHT CONNELLY**

**DENNIS HAUCK**

**RICHARD H. HALL**

**ROBERT V. PRATT**

Editor/Publishers Emeritus

The MUFON UFO JOURNAL is published by the Mutual UFO Network, Inc., Seguin, Texas. Membership/Subscription rates: \$15.00 per year in the U.S.A.; \$16.00 foreign in U.S. funds. Copyright 1984 by the Mutual UFO Network. Second class postage paid at Seguin, Texas. POSTMASTER: Send form 3579 to advise change of address to The MUFON UFO JOURNAL, 103 Oldtowne Rd., Seguin, Texas 78155.

# FROM THE EDITOR

When grown men speak of babes, as they recently did in connection with the Rendlesham Forest Affair, it's time to take UFOs and UFO witnesses seriously. If you saw the recent CNN-TV four-part series on Rendlesham, you heard one of the American security officers involved in the affair say, in effect: "They were like little children. That's what I kept thinking the whole time." What I keep thinking is that we've yet to hear the last out of England on this remarkable case. In the meantime, you'll find two articles about Rendlesham in this issue of the Journal.

We also have the text of a speech delivered by Charles E. Barnum at the 1972 Midwest UFO Conference. Barnum was the editor of the Quincy, Illinois, "Herald-Whig," and the recipient of the 1972 Wells Memorial Key Award presented by Sigma Delta Chi, the professional journalism society. His was the keynote speech at the conference, but since it was not included in the annual Proceedings, we are reprinting it now because it is still as relevant as when it was first presented.

We hope you enjoy the present issue of the Journal and look forward to your comments and criticisms. Coming up soon, pictures and an interview with Dr. J. Allen Hynek, James McCampbell's "Hum and Whistle a UFO Tune," and Michael Sword's intriguing "Ufonauts: Homo Sapiens of the Future?"

## In this issue

NEWS'N' NOTES, By Dennis Stacy .....	3
ESTIMATE OF THE SITUATION, By Marge Christensen .....	4
EARTHLIGHTS REVIEWED, By Gregory Long .....	7
WHAT HAPPENED IN RENDLESHAM FOREST? .....	10
UFOS & THE MEDIA, By Charles E. Barnum .....	13
THE RENDLESHAM FOREST AFFAIR, By Walt Andrus, Jr. ....	17
LETTERS .....	18
DIRECTOR'S MESSAGE, By Walt Andrus, Jr. ....	20

The Mutual UFO Network, Inc. is exempt from Federal Income Tax under Section 501(c)(3) of the Internal Revenue Code. MUFON is a publicly supported organization of the type described in Section 509(a)(2). Donors may deduct contributions from their Federal income tax. In addition, bequests, legacies, devises, transfers, or gifts are deductible for Federal estate and gift tax purposes if they meet the applicable provisions of Sections 2055, 2106, and 2522 of the code.

The contents of the MUFON UFO JOURNAL are determined by the editor, and do not necessarily represent the official position of MUFON. Opinions of contributors are their own, and do not necessarily reflect those of the editor, the staff, or MUFON. Articles may be forwarded directly to MUFON. Responses to published articles may be in a Letter to the Editor (up to about 400 words) or in a short article (up to about 2,000 words). Thereafter, the "50% rule" is applied: the article author may reply but will be allowed half the wordage used in the response; the responder may answer the author but will be allowed half the wordage used in the author's reply, etc. All submissions are subject to editing for style, clarity, and conciseness. Permission is hereby granted to quote from this issue provided not more than 200 words are quoted from any one article, the author of the article is given credit, and the statement "Copyright 1984 by the Mutual UFO Network, 103 Oldtowne Rd., Seguin, Texas" is included.

### GRAY BARKER DIES

1984 saw the passing of another early member of the original UFO movement. Kenneth Arnold, whose sighting initiated the modern era, died in January of last year, and on December 6th, after a lengthy illness, Gray Barker passed away in Charleston, West Virginia. A longtime devotee, publisher and writer of UFO and related material, Barker will probably be best remembered by his "Saucerian" magazine and the controversial book, *They Knew Too Much About Flying Saucers*.

The latter recounted the exploits of UFO investigator Albert K. Bender and his allegations that he had been hushed up by "three men in black," a theme which has since recurred in the writings of John Keel, among others, and firmly ensconced itself, for better or worse, in the modern UFO lexicon. Like Arnold, Barker was a legend in his own time and will be missed by his circle of friends.

### IFO RESEARCH

On another front Hobart Gregory Baker writes to announce the formation and goals of the Center for Identified Flying Object Studies. Baker, a graduate in physiology from Ohio State, says the new organization is independent of other established UFO groups but will co-operate freely with both them and individual parties.

Baker, director of the Center, says the organization "will study the reliability of testimony of UFO and IFO observers, the factors that enhance, suppress and distort the testimony of UFO and IFO observers, and determine the similarities and differences of UFOs and IFOs." The Center will support a data base of sighting reports of both UFOs and IFOs upon which statistical analyses can be performed.

Those wishing more information should write to: Hobart Gregory Baker, CIFO, 113 E. Northwood Avenue, Columbus, Ohio, 43201.

### MISSING BLOOD?

The following subject would not normally come up except that it is not every day one gets to attend a mutilation, as I was recently privileged, if that is the word, to. One of the most compelling factors of the animal mutilation mystery was the supposed absence of copious amounts of blood either at the mutilation site or in the carcass of the victimized animal itself.

Where did the missing blood go? Was it drained through pencil-sized holes in the jugular vein by extraterrestrial vampires? Or was it extracted by terrestrial scientists conducting supersecret germ and/or genetic warfare experiments? There were other bodies of thought between the two extremes as well.

This problem took on a less abstract and more concrete realism last December when an old friend, now a reporter with one of the major Canadian dailies, and I vacationed in the Yucatan and Quintana Roo states of Mexico. December, of course, in Mexico is a month long celebration. Each community has its own Saint, time and mode of fiesta. In Isla Mujeres, where we were staying, the celebrations ran from the first of December until the eighth, were devoted to the Virgin of the Immaculate Conception and culminated in a Sunday bullfight (the traditional bullfight season in Mexico is the middle of the summer).

We had seen the crude ring of corrugated tin and sticks before, but now it was crowded with a mob of screaming spectators. We scrunched our way in and made it up to the second level, composed of a precarious, tree-limb floor. From here, I was able to

expose a 36-frame roll of color slide film, using primarily a 35-105mm Zoom.

At first we thought the bullfight was a sham, a comic fair to go hand in hand with the religious festivities of the week before. After all, the "matadors" were dressed in yellow rain-capes!

Then suddenly the bull stood back, two bandilleras protruding from his right shoulder. Blood had been drawn and was plainly streaking down his flank. A young matador approached, surely less than fifteen. He flourished a red cape in his hands, supported by a hidden sword. He plunged the sword in the bull's shoulder, aiming for the heart, but apparently missed. An older man finally made the kill with several stabs of his own sword.

But the bullfight was only a mild prelude to what was to follow. As we made our way down and outside, the dead bull was roped and drawn from the ring by its neck. It was deposited virtually at our feet and to our amazement two men set to butchering the carcass immediately.

To my further amazement, they drew hardly any blood. Not that there were not visible amounts of blood, there were, rather there was not nearly as much as I might have expected. Each man had an approximately 10-inch long butcher knife and sharpening tool and another man later applied a hacksaw to some of the leg bones.

The first cut, however, went from stern to stern of the bull's tender underbelly. With deft, short strokes of their knives, the two peeled back the skin from both flanks. Now the bull was lying on its back, all four legs in the air, and a good yard of soft hide spread on either side for use as a butchering blanket.

Underneath its skin the bull looked like some mutant albino. The second layer appeared to be a white sheath of subcutaneous fat that was almost

(continued on page 19)

# ESTIMATE OF THE SITUATION

Marge Christensen

## RESPECT

In the October, 1984 issue of the *MUFON Journal*, editor Dennis Stacy, in his column, "From the Editor," quoted Rodney Dangerfield in saying (regarding UFOlogists), "We don't get no respect."

If you think that UFOlogists "don't get no respect," try public school teaching for awhile. It's no secret that public education in the U.S. is under fire from critics in every aspect of society. In fact, I often find that I get more respect when introduced as a *UFOlogist*, than when I am introduced as a teacher!

Morale in teaching is so poor that the entire teaching staff of our school system has been instructed by the Supt. of Schools to list as our #1 goal for this year, that we *will be positive*. As simplistic a prescription as this sounds for combatting the forces of negativism, it is not such a bad idea.

If one manages to maintain a positive outlook, it will enable him/her to keep sight of the fact that it is the students and the education process itself which are of prime importance, not the public regard for teachers. This stance, can only result in increased public respect for educators.

UFOlogists would do well to take a lesson from this analogy. If we can manage to be positive about the UFO subject, and our role in researching it and increasing public awareness of the phenomenon, we will then expend less of our valuable energies combatting biased, venomous dribble from the skeptics, and perhaps we will accomplish a great deal more constructive work in the field as a result. Our "respect rating" by the public would very likely rise a few points also.

During the past months, many of us (notwithstanding this author) have tended to take note primarily of the negative side of the state of affairs in

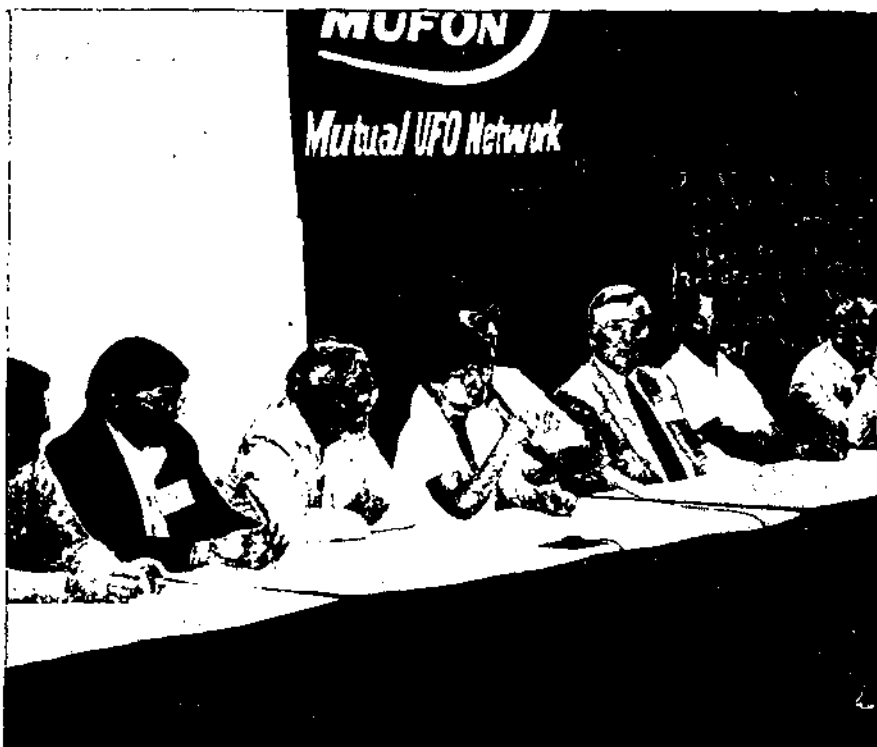

Marge Christensen (center) on the Speakers' Panel at the 1984 MUFON Symposium

—Dennis Stacy

UFOlogy. Fortunately, in my fervor to be positive as a teacher, I recently unconsciously let some of that uncontrolled enthusiasm spill over into the UFOlogist side of me. The results were not only eye-opening, but quite heartening and very promising.

Rather than risk being accused of a "Polyanna attitude," I should mention that as your PR Director, I have a distinct advantage over most of you, and that is that I have established a very active and extensive communication system with several State Directors and Asst. State Directors, so I am able to view the operations of our mutual network from a comprehensive vantage point.

While I have observed that it is true that apathy abounds among our membership, there are also clear indications that this situation is beginning to slowly give way to a new "conscientious activism." The MUFON

National Newsletter has begun to bring about a much more active communications network and a great deal more active participation on the part of State Directors across the country. People who were previously simply names on a piece of paper are now communicating with one another and sharing information and providing mutual assistance. This has brought about a greater sense of cohesiveness in the organization, as well as a greater degree of efficiency in getting the job done.

Also, there is a movement toward accountability and professionalism on the part of all of us, and that movement is rapidly gaining momentum. Dan Wright, Michigan State Director, has compiled a comprehensive examination for field investigators, and has invested a great deal of time and

(continued next page)

## SITUATION, CONTINUED

thought into revising the exam to reflect input from consultants, State Directors, field investigators, and members who have responded to Dan's request for feedback. The overall reaction to initiating such an exam has been entirely favorable. This, in itself, is a clear indication of a widespread desire for upgrading our standards and preparedness.

In an attempt to promote efforts to inform the public on the UFO subject, and to provide standardization for our various State organizations, Barry Greenwood, Dan Wright, and Tom Gates are currently compiling two slide presentations — one for the public, and one for training field investigator trainees — which will be made available to all MUFON State organizations at a minimal price in the very near future.

## ARCHIVES

Attempts to better equip our State organizations do not stop there. At the 1984 MUFON UFO Symposium at San Antonio, TX, a proposal was presented for the establishment of regional UFO resource collection centers in order that the wealth of data in our possession be made more readily accessible to researchers. To date, two such regional centers have been established. Barry Greenwood, Massachusetts MUFON Asst. State Dir., has offered to serve as a regional collector, as has Doug Labat, Louisiana State Director. A Massachusetts MUFON member is compiling an extensive computer file of Barry's archives, which comprise one of the most extensive collections of UFO material in North America. The catalog, which already numbers hundreds of pages, will be made available to researchers immediately upon its completion, hopefully by the end of December, 1984. In addition, Massachusetts MUFON has purchased a tape cassette copying machine, and thus has the capability to reproduce audio tape cassettes in large numbers with relative ease. It will also be possible to reproduce other items such as videotapes and to make Xerox copies of paper items if so requested by

researchers, as long as these materials are used for instructional purposes, and not for profit. The computer print-out (book) of resources, as well as any items to be reproduced will be available to interested researchers at minimal cost. It is further planned that Doug Labat's listings will eventually be added to the computer file, so that we will have a more complete listing of available materials. It is also hoped that other archivists will volunteer to serve as regional collection centers.

An additional cause for optimism about our current situation is that there are fairly widespread indications of State organizations expressing a willingness to become actively involved in public education endeavors. At the San Antonio MUFON Symposium, it was announced that in mid-August, 1985, we will hold our first NATIONAL UFO INFORMATION WEEK, and will ask the participation of every State organization. In a recent questionnaire sent to all State Directors, each organization was asked about its potential preparedness to contribute in some way to such an endeavor. Twenty-one State Directors have responded to date.

The following States have indicated a willingness to participate in at least three of the following projects: UFO display at shopping mall or county fairs; one-day UFO conference; press releases to newspapers; appearances on radio or television: North Carolina, Northern California, Southern California, Michigan, Nebraska, Utah, Iowa, Massachusetts, Maine, Pennsylvania, New Jersey, Connecticut, New Mexico, Texas, and Missouri.

Additional projects suggested include seminars in schools; printed posters; one-day teach-in; speakers on college campuses; independent study project with academic credits for college students.

## UFO WEEK

Furthermore, an important development in the preparation for the National UFO Information Week has been the desire of the Fund for UFO Research and the Center for UFO Studies to join us in this important

effort. Dr. Bruce Maccabee has indicated that the Fund will handle all publicity in the Washington, D.C. area. Dr. J. Allen Hynek and Mr. John Timmerman of CUFOS have been extremely gracious in their offers to assist in this endeavor. Mr. Timmerman will be working on some public service announcements for radio stations, and Dr. Hynek is hoping to put together a UFO documentary for television. This genuine spirit of cooperation among our three organizations has always existed, but it is particularly heartening to be able to work together on such a project and to see tangible results.

It is our sincere belief and hope that with increased public awareness of the reality of the UFO phenomenon, it will be incumbent upon the media to offer more responsible, serious coverage of UFO news events. Also, it will be much more difficult for the govt. to withhold information from the public because the public will see through any half-baked debunking explanations of genuine UFO cases. The bottom line is that we will never know unless we make the effort. No one else is going to do it for us. The important thing to note here is that we are going to make that effort in the summer of 1985, and that effort will be a group effort on the part of numerous States.

On an entirely different front, there is reason to be optimistic about the information we have been able to obtain from government agencies recently under the provisions of the Freedom of Information Act. It was recently learned, for example, that "A UFO by any other name might result in document releases." A document received recently referred to sightings of unidentified flying objects as "irregular sighting reports." Requests are already being filed for documents regarding "ISRs." An additional document just received refers to the "agency of the Air Force responsible for investigating UFO sightings." This opens still another door to requests for additional documents. The Citizens Against UFO Secrecy (CAUS) have revived their newsletter, "Just Cause," and have begun making subscriptions available to persons who wish to

*(continued next page)*

## SITUATION, CONTINUED

support their endeavors to file requests under the FOIA for additional documents. This organization warrants our support, and is getting a great deal accomplished in the area of government documents. The annual subscription fee for the CAUS Newsletter is \$10, and should be sent to JUST CAUSE, Box 218, Coventry, CT 06238.

Despite the negative aspects such as the dropouts from our ranks, the constant, unconstructive attacks from the ever-persistent fanatical skeptics, the relative dearth of media coverage on the UFO subject, and the petty squabbling among UFO organizations which sometimes occurs, there does appear to be a ray of optimism beginning to penetrate the cloud cover.

## OPTIMISM

When one considers the various points of this article, in addition to the following summary of events of 1984, one gets a rather new and hopeful perspective of the estimate of our situation:

### 1984 SUMMARY

- 1) Congressional Research Service published *The UFO Enigma*, an amazingly accurate depiction of the UFO subject, even including a copy of the Kirtland AFB document.
- 2) *Clear Intent* was published, and sold out rapidly. The book is already into its fourth printing.
- 3) MUFON 1984 UFO Symposium in San Antonio was a smash hit with a greater financial profit than the previous 14 symposia combined.
- 4) UFO Forum in Beverly, MA, played to a standing-room only crowd, and will now become an annual event.
- 5) UFO Conference in Brewster, NY, attended by 1000 persons, most of whom were witnesses of the strange objects seen over NY and CT. Also, as a result of the conference, there was widespread media coverage of the subject.



Marge Christensen Addresses San Antonio Symposium

-Dennis Stacy

6) The *N.Y. Times* published two pro-UFO articles, an unusual occurrence for that newspaper.

7) A new research institute was donated to the Center for UFO Studies, in Phoenix, Arizona, and this promises to herald a new era of meaningful research into the subject.

8) Closing ceremonies of the 1984 Summer Olympics included the landing of a giant UFO modeled after the one in the movie, "Close Encounters of the Third Kind." This is indicative of the popularity of the UFO subject with the public.

There are other positive events of 1984, but suffice it to say that there is clear cause to believe that the current estimate of the situation is beginning to reflect a distinct hint of optimism.

## NEW ERA

This may be only the beginning of an exciting new era in UFOlogy, only if we work to make it happen. Although the response we have had for the National UFO Information Week has been very positive to date, we still need

the cooperation of those States yet unheard from. Those State organizations in which apathy dominates, need to do some self-assessment and attempt to get their acts together. The members of the Committee on Public Information and Public Education are prepared to provide assistance wherever possible. Specific regions of the U.S. are the responsibility of various members of the committee, and these persons will be in contact with the "silent States" in the near future. It is also up to you to help yourselves to a certain extent. If you haven't already done so, purchasing a copy of the 1984 MUFON Symposium Proceedings is a *must*. There are step by step instructions included for State Directors to use in getting their various organizations off the ground. Also, make use of the telephone. It tends to be a rather effective means of communication. In many cases, help is only a phone call away. Take advantage of low weekend rates.

If everyone pulls his or her share of the job, we can effect a change in the situation in UFOlogy as mentioned

(continued on page 19)

# EARTHLIGHTS REVIEWED

Gregory D. Long

A new school of thought is emerging in UFOlogical speculation. The school is attempting to explain UFOs as the product of geophysical processes that generate high-energy luminous balls of light at faults. These "earth lights" seem to behave intelligently, which is spurious (these thinkers believe) since the "intelligence" behind them results either from common misperception, or even more, from reactions the lights make to some heretofore unknown "psychic" energy transmitted by the unwitting witnesses.

Spokesmen for the school include M. Persinger and G. Lafreniere, authors of *Space-Time Transients and*

*Unusual Events* (Nelson-Hall, New York, 1977); and Dr. William Brandy of the U.S. Bureau of Mines in Denver, who has demonstrated that quartz-bearing rock subjected to high pressure will, upon cracking, release shortlived balls of energy. Supposedly, if this electromagnetic phenomenon can occur in the laboratory, it can occur as well on the grand scale of nature. Persinger and Lafreniere suggest that these balls of energy can, in proximity to witnesses, stimulate the portion of the brain involved in deep-rooted archetypal imagery, sparking hallucinations and "UFO experiences."

Paul Devereux, who lives in Great Britain, is the author of *Earth Lights,*

subtitled *Towards an Explanation of the UFO Enigma*, the most ambitious attempt so far to develop a drum-tight explanation of UFOs as a form of ill-observed, although not so rare, form of electromagnetic energy produced through tectonic stress. Devereux differs from Persinger and Lafreniere in that he does not subscribe to the stimulus/hallucination principle of UFO sightings. Devereux agrees that UFOs originate from geophysical processes, but he also believes that the ancient Neolithic peoples of Britain knowingly erected megalithic stones (such as those of Stonehenge) at places in

(continued on next page)

—artwork by Simone Mendez



## EARTHLIGHTS, CONTINUED

Britain near UFO-producing faults.

The shamans of the Neolithic tribes practiced an "elemental technology," using a form of psychokinesis (PK) in which imagery of the mind interacted with the external energy-forms of nature. This interaction occurred, and apparently still does today — although unconsciously — in the presence of psychically predisposed individuals because the UFO acts as "a carrier of imagery," its substance accommodating the form of the image. Devereux writes:

*The mental signals affecting some UFOs will, presumably, come from different levels of consciousness, and the intensity with which a UFO is likely to respond to such an input into its system will vary with a number of conditions — the proximity of the human "transmitters," the phase of development in the UFO, its level of plasticity and stability at that phase, the ambient electromagnetic conditions, the strength of the PK, and so on.*

Devereux supplies an answer to why ancient stone sites were built (he believes more was involved than predicting astronomical events and erecting a large-scale calendar from stone). The interaction of mind with the energy forms was "an outward representation of profound mental processes..." These mental processes contained the ancient myths:

*Solar heroes, Earth Mothers, demons and giants — all the representations of the forces of physical and mental Nature may actually have taken on tenuous form in the ancient world. It is easy to understand how the vague, inchoate racial memories of this time have come to be misinterpreted in our day and age as references to ancient astronauts.*

In short, the ancient shamans knew how to "activate the outer mechanisms (the earth lights) to present their inner visions."

This powerful psi ability peaked



Paul Devereux, Author of EARTHLIGHTS

— Dennis Stone

around the third millenium B.C., Devereux states, and fragments of The Knowledge exist today although the means of linking the consciousness with the physical world seem to be completely forgotten. However, contemporary UFO sightings are of "shape-shifting" earth lights that display "the elements from the common cultural ethos....If the UFO pageant today resembles nothing more than the incoherent ravings of a fevered mind, then that is the true reflection of our current collective mental situation."

Simply expressed, the earth lights theory proposes a terrestrial source of UFOs, a "profoundly sensitive energy form" that can sustain a humanly transmitted mental image. Or as I would put it: *We have met the UFO—and he is us...under our feet.*

All of this is heady stuff. One obvious problem with the theory is the place of apparently structured, metallic objects in the scheme—and especially those seen under daylight conditions by multiple witnesses. Devereux seems to think that the reports of daylight discs are of earth lights which take on a metallic appearance due to "some refractive process" or "some kind of electrical 'sheen' effect." This

appearance includes portholes, domes and the other "craft"-like appurtenances, such as antennae, common to many daylight objects.

Additionally, Devereux is careful to choose only those sightings of nocturnal lights that could conceivably be taken as the product of earth stress — yet oddly, the selected cases have enough "high strangeness" about them, and the reported objects display such undeniably intelligent behavior, that it is hard to believe that we are dealing with a nonsentient form of energy that is either coincidentally behaving in an intelligent manner as a result of natural effects, or is somehow being shaped by the force of psychokinesis acting at a distance of miles in some cases.

Despite this farfetched approach to explaining the rich variety of UFO appearances as reported by thousands of witnesses all over the world, Devereux does manage to present a compelling argument for the UFO-fault connection in Part 3 of the book: "UFOs As Earth Phenomena." In this section, Devereux correlates stone sites, meteorological and seismic phenomena, the incidence of UFOs,

(continued next page)

## EARTHLIGHTS, CONTINUED

alleged paranormal events and geological features of the landscape to arrive at convincing patterns that UFOs derive from faults and that the ancients may have known of their origin.

Studying records of these events for England and Wales, Devereux graphically demonstrates strong correlation between all the components. As an example, he analyzes the strange lights observed in Barmouth from Christmas 1904 to July 1905, where "The phenomena mainly took the form of lights of all colours, usually globular though sometimes in columnar form..." During the sightings, a religious revival was taking place in the district. Devereux notes that in 1903 an earthquake occurred along the great Bala Fault which dominates the Barmouth area. Devereux wonders if "electromagnetic elements accompanying tectonic events may have triggered mental processes producing the contagious zeal (that the religious leader of the movement) was experiencing" at the time?

Devereux also notes that other prominent UFO "window" areas having faults, such as Warminster and Dyfed, have had reports of UFO sightings that suggest that the phenomena originate from the earth itself. For example, Cley Hill on the Warminster Fault is "a generating and earthing point for the phenomena we call flying saucers or UFOs," he states.

Naturally the Earth-Lights school must precisely describe the mechanisms of luminous-display production. How is it that the earth-lights sustain their form up to 15 minutes, or even hours at a time? How can the lights travel thousands of feet into the air? Why do the earth-lights approach energy sources such as vehicles and power lines, including animals and people? Devereux proposes "energy fields" around people that "attract" UFOs. But what are these fields? Can they be detected? How do they attract earth-lights from thousands of feet away? It is nice to hypothesize "personal energy fields," but what does the term really mean?

Devereux asserts that some UFO

"entities" are formed from the earth-lights themselves, which may form from a columnar "terrestrial discharge event" mistaken by observers as a ghost or otherworldly being. If so, what do we do with all the detailed CEIII reports in which beings are directly associated with landed UFO "craft"? How does an earth-light divide itself up into several humanoids who scoop up soil samples and leap into their vehicle and speed away? How do we explain the rich details of humanoid appearance and behavior? CEIII witnesses must be either extremely stupid or mad.

Devereux also never touches on the problem of the light characteristics of nocturnal UFOs. Why do some nighttime UFOs seem to undergo color transformations? Why is it that some witnesses report UFOs that seem to bear several different lights that blink and flash? Why do some nocturnal lights divide and reform?

It is safe to predict that readers of *Earth Lights* will ask even more questions. Devereux has directly

challenged current thinking in the UFO field which still considers questions of the extraterrestrial or ultraterrestrial source of UFOs. Devereux has taken the time to seek correlations between geological events and lights that are undeniably real. The patterns do exist. But do they exist in *nonfaulted* areas of the world as well? And if the earth lights have always been with us, why has their presence been so little recognized until now? Has the observation and reporting of these lights been the result of a "raised consciousness" on the part of a public newly awakened to the natural world around it due to the expansive spirit of the Space Age? If so, then sociologists and psychologists have a rich arena in which to explore the mechanisms of human perception and social knowledge because the general lack of reports of strange lights before the modern era of UFOs requires an explanation.

*Earth Lights* is published by Turnstone Press Limited, Wellingborough, Northamptonshire, England.



PAUL DEVEREUX

# WHAT HAPPENED IN RENDLESHAM FOREST?

A DRAMATIC tape recording, allegedly made by panic-stricken American servicemen during a close encounter with an alien space craft in a Suffolk forest, is authentic, their former base commander has exclusively told the EADT.

The chilling 20-minute recording, a major new part of the evidence gathered by UFO investigators probing a claimed double landing in Rendlesham Forest, near Woodbridge airbase, was given to the researchers by former base commander Col. Sam Morgan.

The EADT has traced Col. Morgan to the space command headquarters linked to the Peterson Airbase, Colorado and in a frank transatlantic telephone conversation he said, "I do not think it is a hoax."

The tape recording is due to be played at a London Press conference today to launch "Sky Crash — A Cosmic Conspiracy," a book on the alleged incidents which took place on the nights of December 27 and 29/30, 1980.

## Frightened

The incidents were first reported in the EADT and the book's authors, Dot Street, of Blackberry Way, Oulton Broad; Brenda Butler, of Mafeking Place, Leiston, and national UFO investigator Jenny Rendles, claim there has been a conspiracy to cover up the truth about what happened.

Col. Morgan told the EADT, "I think the men really were out there that night and they saw something which frightened them.

"You can hear their excited conversations and references to frightening strange lights. The only opinion I have is,

that based on the evidence available, those guys definitely saw something which cannot be explained.

## Erased

"As for them fabricating it all and putting on an act, I do not think they could have pulled it off."

He gave the tape, part of which had since been inadvertently erased, to researchers because, "There was no reason not to," added Col. Morgan.

The recording was made during the second alleged

close encounter by the then deputy base commander Lt. Col. Charles Halt. His report to the Ministry of Defence on both incidents gave the book's authors a major breakthrough when it was leaked.

## Reports by John Grant

close encounter by the then deputy base commander Lt. Col. Charles Halt. His report to the Ministry of Defence on both incidents gave the book's authors a major breakthrough when it was leaked.

## Stricken

As previously reported by the EADT, it was the first time there had been official confirmation that unusual lights and objects had been seen, and traces of radiation had been found in imprints on the ground and on a tree at the site.

## Shouting

In subsequent evidence given to the investigators, witnesses claimed that in the first encounter three silver-suited "entities" were seen repairing their stricken space craft and some witnesses claimed that contact was established with them.

When his base in Oklahoma was contacted by the EADT, Col. Halt was said to be on duty at a "classi-

fied location" and was unavailable for comment.

The book was written before the investigators heard

the Halt tape but they had heard from witnesses about passages in it. They claim it tells of a "red, sun-like light" which flies through the forest and silently explodes into multiple coloured lights.

A small craft, similar to the one in the first alleged encounter, was seen on or close to the ground.

Col. Halt and a small number of men with him quickly retreat amid panic and shouting.

The book concludes that incidents undoubtedly did take place and puts forward

several possible explanations if the UFO landing claims are untrue.

Included among the authors' suggestions is the alleged possibility that the UFO story might be a blind to cover-up tests on weaponry which went wrong.

## Inquiry

Or, they say, the Americans might even have recovered by helicopter part of the Russian satellite Cosmos 749 under cover of darkness when it was accidentally dropped into the forest.

In any event, they are calling for a full public inquiry and say they are fully prepared to make all their evidence available to one.

The book is published by Neville Spearman Ltd, of Friars Street, Sudbury, and costs £7.50.

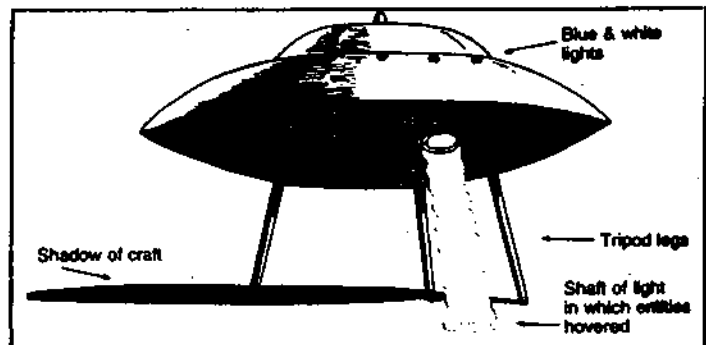

The December 27, 1980, UFO on the ground based on a sketch by an American serviceman.

# Recording of UFO sighting 'not hoax'



Two of the authors, Brenda Butler, left, and Dot Street, on the site of the alleged landing of the spaceship in Rendlesham Forest.

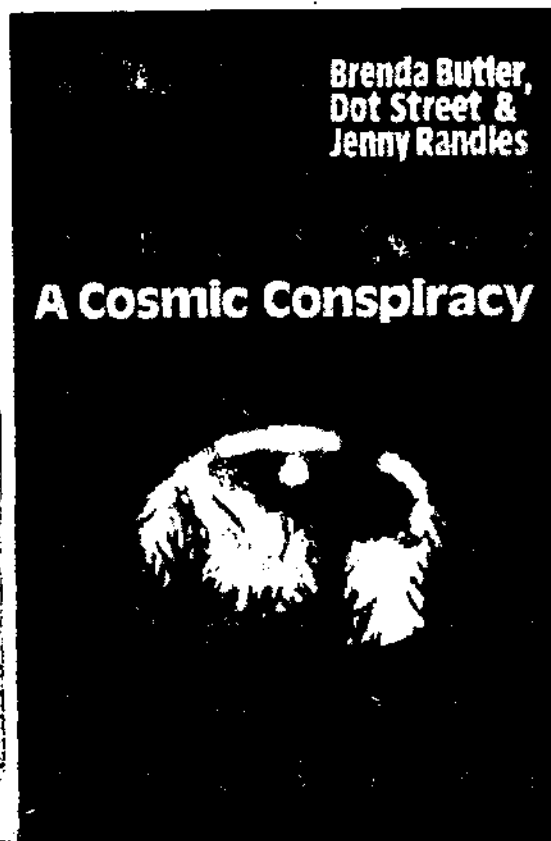

The cover of the new book which claims UFOs landed in Suffolk.

# 'Like the one that got away...'

THE Rendlesham Forest "Sky Crash" incident has been entered in the files of officialdom as "unexplained."

USAF and Ministry of Defence officials accept that something took place... but both say they have no interest in the matter.

The "Sky Crash" story is like the fisherman's tale of the one that got away... it gets bigger each time it is told.

That is the view of Capt. Victor Warzinski, in command of the USAF public affairs department on the Bentwaters/Woodbridge twin airbase.

He told the EADT, "I do not think there was ever any doubt that something happened which we cannot explain."

## *Off-base incident*

But, he said, there was "not the slightest shred of documentation" beyond the report by Col. Halt which is headed "unexplained lights."

Any incident which took place off-base did not come under the jurisdiction of the USAF. The Halt report was therefore sent to the Ministry of Defence and the matter was left to them to handle "as they felt most appropriate."

The USAF had no other course of action open to it beyond making the report available "as a matter of courtesy." Any other action would have been "like sending out our cops to enforce British law," he said.

Asked specifically about the traces of radiation allegedly found at the site, he said that these were "only normal background counts — the sort you or I would get if we went out anywhere and took readings."

The readings were not officially taken. They were obtained by

off-duty personnel. Asked why they went to the site unofficially and at night he said, "Your guess is as good as mine."

The USAF would not comment on any of the speculation in the "Sky Crash" book. But of the incidents in general, he said, "I do not get the feeling that there has been any cover-up in any sense of the words."

## *Remembered*

He added, "It is like the old fisherman's tale of the one that got away... it gets bigger each time it is told. The fish in reality does not get any bigger but the story sure as hell does."

The case was instantly remembered by both Ministry of Defence officials contacted by the EADT yesterday.

Spokesman Mr. Dermot Hill said the Ministry's DS8 department had investigated the incidents and had found no defence or military significance or implication and had therefore taken no further action.

## *'Reasonable people'*

"It was looked into and there being no military explanation we lost interest in it.

"I can see perfectly well that reasonable people who are interested in such things would find it very interesting. I am not in any way saying that these people must be crankish or anything of that sort... I am simply saying that the MoD was satisfied there was no military significance."

Col. Halt's report was "thorough" and it was "basically all we have on our files about it."

## RENDELSHAM FOREST, CONT.

"SKY CRASH" material  
from  
"East Anglican Times"  
October 25, 1984

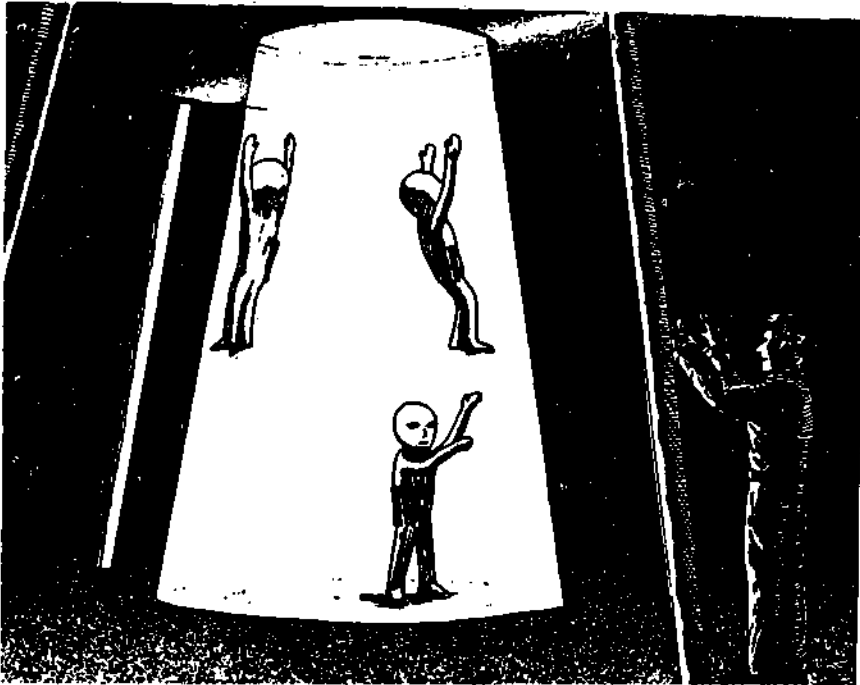

*The American serviceman's view of the alien contact with the base commander.*

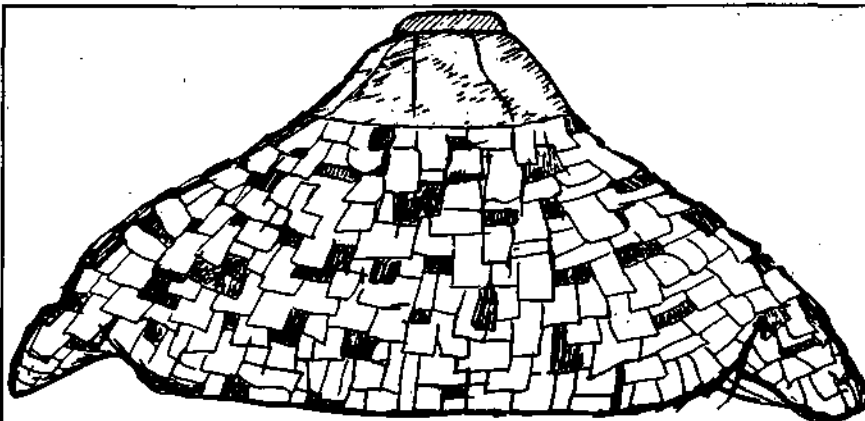

*The craft which appeared after the alleged light explosion on December 30, 1980, as described by an American airman.*

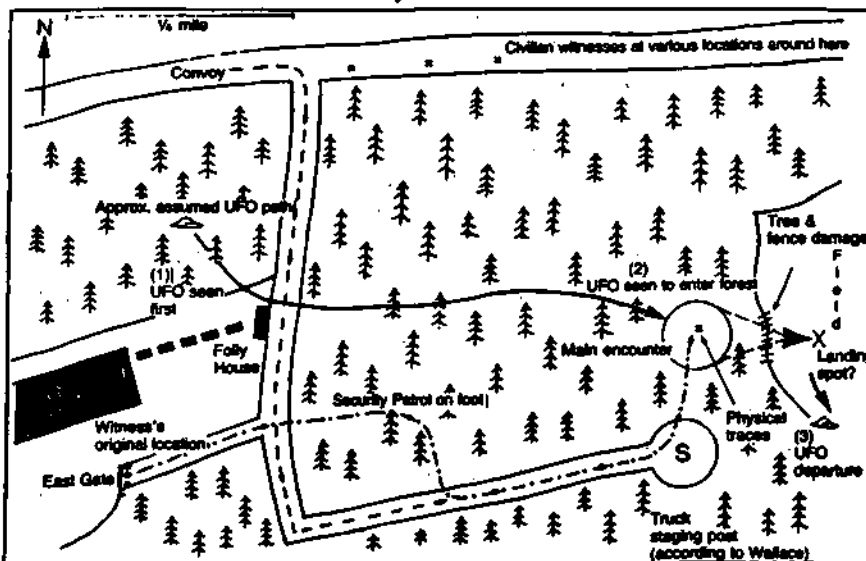

*Map of the path taken from USAF Woodbridge to the site of the alleged encounter with the space craft.*

## MEDIA & UFOS, CONTINUED

an immediate story may be in order and should be reported by someone like Walt Andrus who is level-headed about the phenomenon.

Other ways in which you may aid the news media in keeping the public informed of UFO happenings include:

1. Providing interviews with recognized scientists like Dr. Hynek and Dr. Saunders.
2. Holding conferences such as this which pull together the views of experts in the field.
3. Making appearances before groups such as luncheon clubs, always making sure speakers provide reporters with adequate summaries of their remarks.
4. Releasing pictures of sightings if they tell a significant story.
5. Assisting reporters and editors in pulling together isolated reports and facts so that they may be presented in a total context possessing meaning. A good example here is the significance of the events in 1954 as pointed out by Jacques Vallee.

These are some suggestions I leave with you in the hope that by obtaining your cooperation we in the news media can present a clearer picture of the UFO significance. Additionally, let me say that I'm sure you'll find news media representatives willing to give our field objective treatment if you'll make yourselves available for providing answers which newsmen may need to handle information about UFO's intelligently.

As your so-called keynoter, I'm privileged to welcome you to Quincy, an open-minded city, a truly great city that welcomes new ideas and a city wherein scientific research in many fields has reached a high level of sophistication. Thus, the scientific trend in our exploration of UFO's will attract to its echo a warm welcome from all of us here to all of you.

# UFOS & THE MEDIA

Charles E. Barnum

My good friend, Walt Andrus, asked me to discuss news media in relation to UFO sightings—and then bombshelled me by remarking, "We'll call your talk the keynote speech."

Inserting me as a keynoter in a scientifically oriented gathering such as this is much like asking a lifelong birdwatcher to deliver a paper at a meeting of NASA scientists on a subject such as:

"Location of the engine frame into an airplane's wing, just ahead of the leading edge of the wing, produces the greatest propulsive efficiency while maintaining the best aerodynamic results."

Frankly, I'm here, as most of you are, to learn something; and hopefully to discover that the study of UFO phenomena may be off and running on a scientifically guided course.

As a newspaperman whose skepticism is representative, I believe, of journalists generally, I have approached the problem of handling news of UFO sightings gingerly, even apprehensively.

## FEAR

It's a scary subject; it requires mature handling.

The Orson Welles broadcast in 1938 based on H.G. Wells' "War of the Worlds" seriously disturbed more than one million persons, many of them to the point of panic, according to a study conducted by Hadley Cantril. The story was told in the form of a newscast, but announcements were made before, during, and after the presentation stating it was a play based on Wells' novel about an invasion from Mars.

And because "humanoids" are also involved in the UFO picture, editors and newsmen generally must develop ways of presenting reports of sightings which they receive so as not to cause uneasiness, or, indeed, fear.

Thus, when I learned such a

conference as you are now engaged in was contemplated here, I felt a sense of gratitude to the conference planners. We now have an opportunity to use conference materials as a basis for giving our readers a coherent, more comprehensive and authoritative look at the UFO experience.

Additionally, such a conference has educational advantages for news media representatives, as well as others, to learn more about the UFO activity in the context of deliberate consideration and discussion, apart from emotional, even traumatic response to inexplicable strangeness.

Such knowledge should enable all of us in media work to handle news of UFO activity more intelligently, and perhaps with less skepticism. Our need—and this arises somewhat from the fact we've been susceptible to stories arising from misperceptions—is to achieve perspective on the whole complex subject. Moreover, we need to be helped by better screening of reports reaching us, so that we can provide our readers a better, more coherent picture of what is happening on the UFO front.

At least for several colleagues and myself, now that you are in town, a quote from Jack Taylor, of Missouri, seems apropos. He remarked about the new minister at his church: "Our new pastor is doing a wonderful job. We didn't know what sin was until he came to town."

I must acknowledge that as a skeptic I've had my skepticism blunted and my interest aroused by several books on UFO's and one book in particular. It is "The UFO Experience, a Scientific Inquiry," by Dr. J. Allen Hynek, Chairman of the Department of Astronomy of Northwestern University, your 1970 Conference headliner.

After reading Dr. Hynek's book and some other material on UFO's, I'm prepared to acknowledge, "You're undoubtedly dealing with something

that needs, not sniggering, but downright enlightened interest by the scientific community." And I might add, the something referred to needs our news media's careful attention and handling.

## UFO FOCUS

I also will acknowledge, on the basis of a somewhat superficial survey, as I did not have available a wide assortment of papers, that some of us in the newspaper business have not done enough to bring proper focus on the UFO mystery.

Bringing the UFO experience into a sharp focus entails much more than doing as we have generally done, reporting occasional sightings by individuals in our reading areas.

Even Jesus realized that the folks at home do not a prophet recognize, that one becomes an expert only when he travels far from home. So it is with the credibility of sighters in their own backyards. Their neighbors, and their hometown editors, don't credit them with the qualities necessary for expert observation. In this connection, Dr. Hynek's suggested method of rating credibility makes a lot of sense.

The study I made of reports in the press of UFO sightings impressed me in the same way that reports of the late Senator Joseph McCarthy's charges did. As one read the McCarthy blasts—all isolated—one had a growing feeling of unease, and an undeniable fear that Communists were taking over the government. As each story unfolded, the nation experienced a nervous binge.

What was lacking in the McCarthy case was this: A blockbuster wrapup of the whole McCarthy story, pulling all facets together so that the country could get a look at the complete McCarthy case. If his charges were

(continued on next page)

## MEDIA & UFOS, CONTINUED

solid, the wrap-up would have shown them to be so and would have made him a national hero. But when such a compilation was done by a press association, the McCarthy story exploded and he faded from the national scene. There was no documentation of his charges, and nothing was found to substantiate his statements.

As for the UFO phenomenon, I consider the Dr. Hynek book an essential blockbuster wrap-up of the UFO story—pulling together all relevant facets and offering the route to a scientific appraisal of available data.

The UFO story obviously is not going to explode, for Dr. Hynek shows that it has tremendous significance for us and our time, and possesses enough substance to warrant greatly accelerated scientific inquiry.

It was impossible for me to trace a consistent pattern of UFO handling by the news media. I found that some UFO sighters concluded they had been treated too lightly in stories detailing their reports.

For our part locally, I can say that both the electronic and print media have treated UFO stories as straight news events, never minimizing their importance, nor overinflating their significance, or casting aspersions on the persons involved. Also we have reported talks by your local spokesmen, particularly Walt Andrus, fully and accurately.

As I study available materials on UFO's, I have reached several conclusions which might be the same gained by other newsmen after studying the same documents. I cannot, of course, speak for any other newsmen, but I can speak for myself.

My skepticism, which incidentally never reached the point of negative reaction for I tried to be objectively skeptical (whatever that is), has given way to deep interest in the whole subject of UFO's. I credit this change of attitude principally to Dr. Hynek's book. While I was at Northwestern University teaching journalism, I kept abreast of this noted astronomer's activity, and I gained respect for him as a great scientist. So when he says in his



MUFON Director Walt Andrus, Jr., at 1984 Symposium

—Dennis Stacy

book that it's his opinion "that data that now lie scattered about, if properly processed, could establish the substantive nature of the UFO phenomenon beyond reasonable doubt," I believe him.

He refers to these data as akin to low grade ore which must be processed and refined before it is of value.

Let me quote him more extensively at this juncture in order for me to make a point.

### PITCH BLENDE

Writing of this ore, he adds, "Or perhaps a more appropriate analogy might be the case of Marie Curie and the tons of pitchblende that she had to process before they yielded a mite of radium. Those of us who have spent time on the UFO problem are convinced that the probability is very high that there is 'radium in the pitchblende' in the quantities of reports. Although it will be a Herculean task to cull and refine existing UFO data, I feel a rich reward awaits a person or a group that assumes this task with dedication. For if there is indeed 'pay dirt' in the ore of UFO data, it might well represent a scientific breakthrough of

major magnitude. It might call for reassignment and rearrangement of many of our established concepts of the physical world, a far greater event than the rearrangements that were necessary when relativity and quantum mechanics demanded entrance into our formerly cozy picture of the world."

Dr. Hynek, as you may know, concludes his book with these words:

"When the long awaited solution to the UFO problem comes, I believe that it will prove to be not merely the next small step in the march of science but a mighty and totally unexpected quantum jump."

Now here is my point in quoting Dr. Hynek:

Our news media have and will give space to comments like these coming from such an authoritative source. I cite you as an example the article on Dr. Hynek and his views in the Chicago Tribune Sunday magazine of June 4, 1972.

The article interested me particularly because it opens with the following paragraphs and I quote them for a reason. Before reading them, however, let me say that if support on a

(continued next page)

## MEDIA & UFOS, CONTINUED

massive scale is ever to be obtained to do the kind of research that Dr. Hynek, and obviously many of you, are interested in, then material like the magazine article will do much to establish credibility and authority for the project.

### HYNEK

Now may I quote:

"Hanging on the wall of Dr. J. Allen Hynek's office at Northwestern University is a framed cartoon. It shows a flying saucer parked on a college campus and five small creatures confronting a passerby. With antennae sprouting from their helmets and ray guns at their sides, they are asking, 'Could you direct us to that chemistry professor who called us 'swamp gas?'"

"It was Dr. Hynek—an astronomer, not a chemistry professor, who said that strange lights sighted near Ann Arbor, Mich., in 1966 were nothing more than swamp gases released by unseasonably warm weather. Despite his debunking of these sightings, Hynek is not ready to discount all reports of flying saucers. He believes there is a possibility we are being visited by strange craft—and even 'little people'—from another planet. He believes that flying saucers or UFO's—unidentified flying objects—may be something more substantial than mere hoaxes or the results of traumatic experiences.

"Dr. Hynek is an astronomer of impressive credentials, a scientist of as much skepticism as intelligence—and that is considerable. His list of degrees, affiliations, and accomplishments is more than suitable reference for his credibility—and sensibility."

It is, of course, our job in news media to bring before our readers all relevant happenings on our planet, provided we can get adequate information about them. I don't know of any newsman who doesn't try to do this.

We cannot ignore the UFO phenomenon for one reason because many responsible people have become involved, and for another reason because responsible scientists like Dr.



Dr. J. Allen Hynek

—Dennis Story

Hynek and Dr. David R. Saunders are lending their prestige to find scientific answers to the problem.

And while we have a duty to report much of what is happening on the UFO front—and to a limited degree we do—we also must keep our eyes open to the interrelationships that may exist between the UFO mystery and other scientific fields of inquiry.

One of our journalistic difficulties, or perhaps shortcomings might be a better way to express what I mean, is our reluctance—with some notable and laudatory exceptions—to seek out and report the context of events, or simply to put isolated reports, as for instance UFO sightings, in meaningful context.

Let me illustrate. Since the 1969 Condon Report, whose authors, I suppose, thought they were banishing the UFO phenomenon from any further serious consideration, and the closing of the Air Force Blue Book, UFO reports persist in tantalizing the imagination of scientists and others interested in the mystery of space and extraterrestrial life.

Indeed, the UFO phenomenon persists like our peculiar style of downtown architecture—contemporary neglect.

It is worth noting here that the Condon Report's stature was most certainly enhanced when the National Academy of Sciences fully endorsed it and its methodology.

Were we to put the UFO picture in true perspective, therefore, a story is in order reporting continuous UFO sightings of various degrees of credibility—all over the globe. In other words, there's a story here that some of us haven't reported, and I haven't seen it elsewhere, though I may have missed it.

But there's another story of greater significance and import involving the National Academy of Sciences. And this story's dimensions enhance a subject closely akin to the subject matter engaging your attention at this conference.

The story was handled deftly and imaginatively by John Lear, Science Editor of *Saturday Review*, in the June 10, 1972, issue. Lear's piece is a fine job of reporting, and is good journalism, for he has given scope in depth of another development of great scientific potential. You here could with justice hail the revelation contained in a

(continued next page)

## MEDIA & UFOS CONTINUED

document released by the Committee on Science and Public Policy of the National Academy of Sciences that a special panel of two dozen astronomers believes that there is such a thing as extraterrestrial intelligence. The astronomers, in short, believe life exists on the planets of many stars other than the sun, and that the extraterrestrial creatures involved may be trying to communicate with other beings in the universe.

Lear's article was headlined, incidentally, "The search for man's relatives among the stars."

Lear introduced his article by posing an imaginative want-ad that reads as follows:

"Historic opportunity: Is a generous person who can afford to spend \$70 million of his own money willing to spend it in hunting for man's long-lost relatives far out among the stars? Will this person please contact Prof. Melvin Calvin, chairman, Committee on Science and Public Policy, National Academy of Sciences, Washington, D.C."

Because I believe it has intense interest here, I am picking up Lear's paraphrase of the NAS document, a liberty I'm sure the *Saturday Review* will forgive, for it should whet your appetite to buy the magazine and read the entire article:

"During the last few years so many of the primitive molecules from which the building blocks of life on earth are made have been seen in the distant sky that the existence of life on the planets of many stars other than the sun can be taken for granted. The inhabitants of some of these planets must be at least as intelligent as we are, and it is logical to assume that they use the electromagnetic spectrum to communicate with each other over long distances, as we do. We could eavesdrop on their messages now if we tried hard enough. Because our own fate as a species ultimately depends on our willingness to recognize ourselves as evolving creatures in an evolving environment, we cannot afford to wait much longer before beginning to listen seriously for clues to the whereabouts of these remote civilizations, locate



Charles E. Barnum, Keynote Speaker

them, and try to engage them in conversation, pending the still unforeseeable time when discovery of new physical laws may allow us to visit them or permit them to visit us."

The NAS report said in addition that "at this instant through this very document are perhaps passing radio waves bearing the conversations of distant creatures, which we could record if we but pointed an existing radio telescope in the right direction and tuned it to the proper frequency."

The articles I have quoted from are excellent examples of good press coverage of man's search to unlock the doors to the unknown and thus enrich the destiny of all of us here on earth.

Dr. Hynek expressed the wish for a massive scientific investigation of the UFO phenomenon. Such an investigation would take the same kind of money Lear seeks for NAS's probe for extraterrestrial life—a goal believed entirely achievable if sufficient resources are forthcoming.

### UFO COVERAGE

Unraveling of the UFO mystery, too, is possible, in my view after an altogether too brief study of press and book coverage of UFO's. But this will take time, effort, and all the enthusiastic persistence you who are studying

UFO's can muster. In fact, you'll have to go way beyond the motivation of a certain doctor in our town who doesn't operate unless it's necessary. If he doesn't need the money, he doesn't operate.

Meanwhile, back on the farm. I've been forgetting my purpose here. I'm a feeble keynoter; in fact, I've wandered a bit from the so-called topic Walt assigned me.

Strictly hewing to our performance record to date—with some exceptions—our job is to remain objectively interested, reporting UFO sightings without bias.

In closing, I have several suggestions concerning the way UFO's should be reported—these suggestions come from many of us in the news media.

Rushing to news rooms with stories of isolated sightings by one or two individuals will neither serve the cause of UFO scientific inquiry, nor the public's need to know. You realize only too well that sometimes you take months to verify the substance of such reports, so hasty publication might be misleading and present the whole UFO picture in a bad light.

Certainly, if a UFO is witnessed by several, say 5 or more, reliable persons,

(continued, page 12)

# RENDLESHAM FOREST AFFAIR

Walt Andrus, Jr.

## **SKY CRASH: A Cosmic Conspiracy**

By: Brenda Butler, Jenny Randles and Dot Street

Published by:

Neville Spearman Limited

The Priory Gate, Friars Street

Sudbury, Suffolk, England

Published: October 25, 1984

Price: 7.50 pounds

SKY CRASH is a culmination of nearly three and one-half years of research on one specific UFO case that involves close encounters of the first, second and probably the third kind. The question posed is: "what really happened in the Rendlesham Forest in close proximity to the east gate of the U.S.A.F. Base at Woodbridge on the nights of December 27 and December 29/30, 1980?" Starting from a rumor, Brenda Butler, through her personal contacts at two major U.S. Air Force bases, discovered an event like the plot from a science-fiction movie. For who could believe in tales of contact between the authorities of this world and the explorers of another alien realm? "It was like something out of *Star Wars*," one witness has explained.

Even though the plot for SKY CRASH reads like science-fiction, if what the authors have been told by several different sources was even remotely near the truth, then Rendlesham Forest has played host to one of the most significant events in the history of this planet.

## **BREAKTHROUGH**

Steve Roberts, a security officer in the U.S.A.F. stationed at Bentwaters/Woodbridge, provided the first clue to Brenda six days after the December 27th monumental event. Realizing one person was inadequate to investigate a sighting with this potential, Brenda shared her information with Dot Street. The two worked as a team during the

latter part of January, 1981. In February 1981, Jenny Randles became part of this intriguing mystery and subsequently summarized the entire case, as it was then known, into the book SKY CRASH.

The credentials for these three "super-sleuths" are as follows: Brenda Butler — housewife and independent investigator of strange phenomena from Leiston, Suffolk, and family friend of Steve Roberts; Jenny Randles — fulltime author from Warrington, Cheshire, and Director of Investigations for the British UFO Research Association (BUFORA); and Dot Street — housewife and accredited regional investigator for BUFORA from Oulton Broad, Suffolk. As a full-time freelancer with several books, Jenny Randles was able to tie all of the loose ends together and write SKY CRASH with the research aid of Brenda and Dot.

The three author/investigators have written SKY CRASH in a chronological sequence which follows their unremitting search for the truth to the initial rumor. It is not the typical UFO story, since it contains all the ingredients of a spy thriller: fear spiced with mystery, intrigue and devastating consequences. Using the writing techniques of Sir Arthur Conan Doyle and Earle Stanley Gardner, Jenny Randles has the reader anticipating what new clue will unfold as the persistent investigation continues. The format is clearly that of a detective thriller, though SKY CRASH is backed up by documented testimony and demonstrates an official cover-up from the very beginning.

## **CONFIRMATION**

The evidence is undeniable, supported as it is by official confirmation from both the Pentagon and the British Ministry of Defense. It is impossible to confront this evidence

and conclude that something strange did not take place in Rendlesham Forest on the nights in question.

Since I consider this book and its investigation one of the most significant cases of the modern era, I will make no attempt to review it in depth, but will instead recommend it to all serious UFO investigators and researchers. SKY CRASH is probably the finest example of how a rumor about a UFO landing is diligently pursued, and how three competent and experienced investigators unearthed clues and solved an insurmountable jigsaw puzzle over a three year span.

## **CREDIT**

We must give the majority of the credit to the three tenacious English investigators for their "never-say-die" attitude when they were confronted with government secrecy by both British and United States officialdom. At the same time, we must also acknowledge the outstanding work by Barry Greenwood, Larry Fawcett and Lucius Farish in the U.S., who provided numerous pieces of the puzzle. Without this cooperative investigation, transatlantic telephone calls, utilization of the Freedom of Information Act, etc., the key evidence would probably not have been forthcoming, since it was indeed a U.S. Air Force event and not a Royal Air Force incident. The authors have acknowledged credits and expressed their gratitude to each of the key participants in their book by name where permitted. Pseudonyms have been used throughout and are so identified to protect the witnesses; in addition, the book clearly depicts the unfortunate treatment dealt U.S. airmen and British civilians when they were subsequently exposed.

Practically all U.S.A.F. personnel

(continued next page)

## SKY CRASH, CONTINUED

witness to the events on December 27 and December 29/29, 1980, were promptly transferred from the Bentwaters/Woodbridge base to other assignments throughout the world to make them more difficult to locate and interview.

It is conceivable that several of the base officers, who were also witnesses, were later promoted in rank as a means of obtaining their cooperation and silence.

Accolades to everyone involved in the research and writing of SKY CRASH for their quest in search of the truth. In the prologue to the book, the authors briefly state their own feelings in this regard: "We concluded that we had no more right to the facts than you have. Since we collected them in our long fight for truth, they were potentially available to anybody who tried hard enough. Consequently, this provided the obvious course of action. We should set down all the facts that we collated, and let you sift through them and judge according to your own fair appraisal."

Brenda, Dot and Jenny have demonstrated the persistence and courage that few investigators could mount against such seemingly impossible odds. This superb work, aided by the outstanding research of fellow investigators in the United States, should shine like a beacon for all of international ufology.

---

## LETTERS TO THE EDITOR

**Dear Editor,**

As a subscriber to the *Journal* and one fully aware of the paradoxical nature of the UFO phenomenon I would like to express some thoughts I have had after reading several articles presented in recent issues. Basically I would like to address this letter to those individuals who consider themselves field investigators and/or write articles on this group of phenomenon.

18

From the very beginning the term 'UFO' was intended to indicate an object, apparently manufactured, whose design seems to exhibit a level of technology higher than our own and whose motions seem to defy our commonly accepted laws of physics. This is not to imply that a UFO must be 'nuts and bolts', but that it is a device! Presently the term 'UFO' seems to be thrown into any situation where an observer cannot readily identify what he is seeing. If such a sighting then turns out to have a conventional or natural explanation it only serves to detract from the reality of the UFO phenomenon as a whole.

I would like to see field investigators concentrate their efforts on investigating 'high-strangeness' incidents, UFO reports that fit the criteria! This is not to say that reports of nocturnal lights or otherwise should not be recorded and checked, but the case for UFO's would be best served by concentrating on those sightings that stand the best chance of yielding significant results.

As for the articles published on this topic, I would prefer to read in-depth interviews with persons influential in this field of study, or updates on recent events. Perhaps one page with a simple break-down of extremely current reports by day, date, location, and category would be simple and informative as far as general sightings are concerned. Far too often I have read a step-by-step account of a nocturnal light that indicated nothing that truly qualified it as a UFO. Too many articles on this phenomenon turn out to be 'stories' instead of informative articles.

At times it appears that the area of 'UFO phenomenon' has been made so broad that anyone wanting to take a figurative 'shot' at it will be assured of hitting something. The phenomenon itself has come to encompass a hodgepodge of Fortean elements and therefore it becomes even more crucial that we remember that what we are trying to establish is not the existence of a UFO phenomenon, but the existence of a UFO!

Sincerely;  
**Christian P. Lambright**

### UFO NEWSCLIPPING SERVICE

The UFO NEWSCLIPPING SERVICE will keep you informed of all the latest United States and World-Wide UFO activity, as it happens! Our service was started in 1969, at which time we contracted with a reputable international newspaper-clipping bureau to obtain for us, those hard to find UFO reports (i.e., little known photographic cases, close encounter and landing reports, occupant cases) and all other UFO reports, many of which are carried only in small town or foreign newspapers.

"Our UFO Newsclipping Service issues are 20-page monthly reports, reproduced by photo-offset, containing the latest United States and Canadian UFO newsclippings, with our foreign section carrying the latest British, Australian, New Zealand and other foreign press reports. Also included is a 3-5 page section of "Fortean" clippings (i.e. Bigfoot and other "monster" reports). Let us keep you informed of the latest happenings in the UFO and Fortean fields."

For subscription information and sample pages from our service, write today to:

UFO NEWSCLIPPING SERVICE  
Route 1 — Box 220  
Plumerville, Arkansas 72127

Lawrence Fawcett and Barry J. Greenwood

# CLEAR INTENT



**THE GOVERNMENT COVERUP  
OF THE UFO EXPERIENCE**

**What does the government know  
about UFOs and why won't it tell us?**

With a foreword by Dr. J. Allen Hynek

## NEWS 'N' NOTES CONTINUED

nowhere touched by the butchering. The men clearly knew what they were doing and worked rapidly, pausing only to sharpen their tools. They shared a single bucket of water into which they occasionally dipped their hands.

On a whole, the operation was remarkably bloodless, even when they cut into the chest cavity and later removed the legs. In less than an hour the entire bull was history, having been field-dressed, hung on hooks and sold off. On the ground itself there was hardly any blood at all, the great majority being contained by the bull's flayed hide.

The point I am trying to make here is that incredibly deft and devastating violence can be wrought on a fresh carcass by skilled hands, in the field, and leave only an amazingly small residue of blood behind. It does not require covert funding or extra-terrestrial spacecraft, and I might not have believed it myself if I had not seen it with my own eyes.

## SITUATION, CONTINUED

earlier. If people simply don't care enough, perhaps then we deserve to get "no respect." I, for one, strongly object to that statement. I think that history will show that we deserve the public's respect and gratitude for our farsightedness and determination in researching one of the most important enigmas of our time, and one which will someday impact just about every facet of earthly life.

Let us hope that the next time that someone submits an estimate of the situation to the Journal for publication, that it will not be of the pessimistic nature of those we have seen in the past. Only we can make the difference. Think about it. And, think *POSITIVE*.

## DIRECTOR'S MESSAGE, CONT.

Atlantic Ocean has been an ongoing detective case for the authors and researchers in the U.S.A.

\*\*\*

Several people have asked **Stanton T. Friedman** and MUFON in Seguin how they might obtain video copies of his movie "UFOs Are Real," since FOTOMAT no longer carries it in their stock. Stan has advised that he is pleased to provide a videotape of the 93-minute, full-length documentary for a price of only \$50.00 U.S. funds which includes first class postage. As technical advisor for the film, Stan tried very hard to keep out the last two minutes dealing with the Bill Meier hoax in Switzerland, but was unsuccessful. People who would like to purchase a copy of this very good documentary (originally produced for motion picture theatres but not used) should specify VHS or Beta format and write to Stanton T. Friedman, 110 Kings College Road, Fredericton, New Brunswick E3B 2E7, Canada.

Stan has also been using the "Access to Information Law" in Canada to secure UFO documents, clearly indicating that the Canadian Government has also been deceiving the public just as 4000 pages of documents obtained under the Freedom of Information Act (FOIA) confirm in the United States. Even though the Canadian law is relatively new, and costs \$5.00 per submission, Stan has found that many of the documents that he most wanted have been destroyed in the past, but there are plenty still available.

\*\*\*

During a recent telephone conference call with host members of the MUFON 1985 UFO Symposium in St. Louis, they corrected a previous statement in the Journal in my *Director's Message*. **Ken Hanke** is the Assistant Chairman for the 1985 Symposium. I had listed both he and his wife, Helen, as Assistant Chairpersons. Helen is heading up one of the committees.

\*\*\*

**Bruce Maccabee** and the Fund for UFO Research announced on September first that UFONET had been placed on "temporary hold" after a four month period of operation in

which the expenses had been greater than anticipated (i.e., \$1.00 per minute of connect time to the computer plus about \$ .10 per minute telephone long distance expenses). Over the past four months the expense had averaged several hundred dollars per month with only about a dozen active participants. The Fund has estimated that it would cost as little as \$12.00 per month per user to maintain UFONET at a low level of operation; that is, participants would check in several times a month. In view of the expenses described, the Fund has invited interested people to write a letter indicating whether or not they would be willing to pay part of the UFONET costs, and if so, at what rate — \$10.00 per hour, \$5.00 per month, etc.

In the meantime, **Michael D. Hart**, Director of the COMPUFON NETWORK, 803 5th Place S.E., Duvall, WA, 98019 has set up a computer network as of November 20, 1984. Anyone in MUFON or elsewhere that would like access to the new Network should contact Michael at the above address or by telephone during the day at (206) 788-5307 and he will supply them with the pertinent information. There is no charge for the use of the system, although there is the cost of the long distance call made by each user. The system allows access by any of the present computers on the market such as Apple, I.B.M., Kaypro, Commodore, Atari, Texas Instruments, etc. Mr. Hart is the State Section Director for King County.

\*\*\*

MUFON has obtained one hundred additional copies of the third printing of *CLEAR INTENT* (paperback) which are available for \$8.95 plus \$1.50 for postage and handling in U.S. funds. Foreign subscribers must use an International Postal Money Order or a check drawn upon a bank in the U.S.A., since collection costs of other checks exceeds the face value of the check. The MUFON Journal Staff would like to take this opportunity to extend our best wishes for the new year to our friends around the world.

# DIRECTOR'S MESSAGE

by  
Walt Andrus

**Thomas P Deuley** has become the new State Director for Texas replacing the Reverend **G. Neal Hern** who resigned due to increased responsibilities within the Episcopalian Church in the Dallas Diocese. In addition to serving as the MUFON Corporate Secretary and Art Director for the MUFON UFO JOURNAL, Tom is also a member of the Board of Directors of the Fund for UFO Research. He was the Host Chairman for the MUFON 1984 UFO Symposium in San Antonio and just completed two terms as President of MUFON of San Antonio.

\*\*\*

**Bob Grattan**, State Director for Virginia, recently received a Fulbright Scholarship to teach library automation and computer literacy in Tunis, Africa, at the University of Tunisia from December 1984 to August 1985. Mr. Grattan has been alerted to seek a professional ufologist in Tunisia to represent MUFON in this north African nation, during his teaching scholarship.

\*\*\*

**Marge Christensen**, Public Relations Director, has announced plans for the National UFO Information Week to be held from August 18 to 25, 1985 in the MUFON P.I.P.E. Line newsletter to State Public Relations Directors. Each local group should start now to make plans for public UFO exhibits, one day seminars, publicity in the local news media, video documentary displays, lectures, etc. in order to be prepared for this ambitious nation-wide public education event. MUFON will provide printed handouts on UFO information (8½ x 11"), one sheet, both sides, with the MUFON address (international) and space for stamping the name of the local organization sponsoring the event and



TOM DEULEY

the "UFO Hotline" telephone number where available.

\*\*\*

**Dorothy Soutanokis**, office manager for SBI, has advised their members and associates concerning the health status of **Peter Mazzola**, International Director. As many of Pete's friends know, he is retired from the New York City Police Department as a result of injuries sustained that caused permanent nerve damage. Compounding this situation, on the morning of November 9, he was involved in a serious automobile accident requiring hospitalization and remained in serious condition. After nearly three weeks' confinement in the Intensive Care Unit, he developed pneumonia. As of December 5, his doctors say he is recuperating and is expected to be released prior to Christmas to rest and recuperate further at home. It has been suggested that "Get Well" cards be sent to Pete at P.O. Box 193, Staten Island, NY 10312. We wish Pete a speedy recovery.

When speaking of ambitious and significant projects, **David Christensen** had embarked on a computerized file listing all books, periodicals, audio and video cassettes, microfilm and books of news clippings at the MUFON resource centers across the country. Starting with the extensive library of **Barry J. Greenwood**, Staff Historian, and **Doug Labat** in New Orleans, Louisiana, the computerized file already has 600 books, 700 periodicals, 415 audio and video cassettes, 120 rolls of microfilm and 30 books of news clippings. We will be entering the MUFON library in Seguin, Texas, into this file early in 1985. At this stage, David Christensen is not tabulating UFO cases or Government Documents, however plans have been made to do so. This started out as a joint venture with Barry Greenwood and MUFON of Massachusetts, however, it will eventually become a series of national resource centers, designating where information is available. For those of you who haven't met David personally, he is the congenial husband of Marge, and an integral member of the Christensen UFO team.

\*\*\*

The Cable News Network (CNN) has been working for several months on the Rendlesham Forest UFO incident for a TV documentary. December 27, 1984, marks the fourth anniversary of this intriguing event and could be the date of showing on national television. ABC-TV News sent a film crew to England on December 5, 1984, to also film this case known by the title of the new book, **SKY CRASH**, by **Brenda Butler**, **Dot Street** and **Jenny Randles**. Ferreting out more eyewitnesses on both sides of the

(continued on page 19)

# MUFON UFO JOURNAL

NUMBER 202

FEBRUARY 1985

Founded 1967

OFFICIAL PUBLICATION OF



MUTUAL UFO NETWORK, INC.

\$1.50

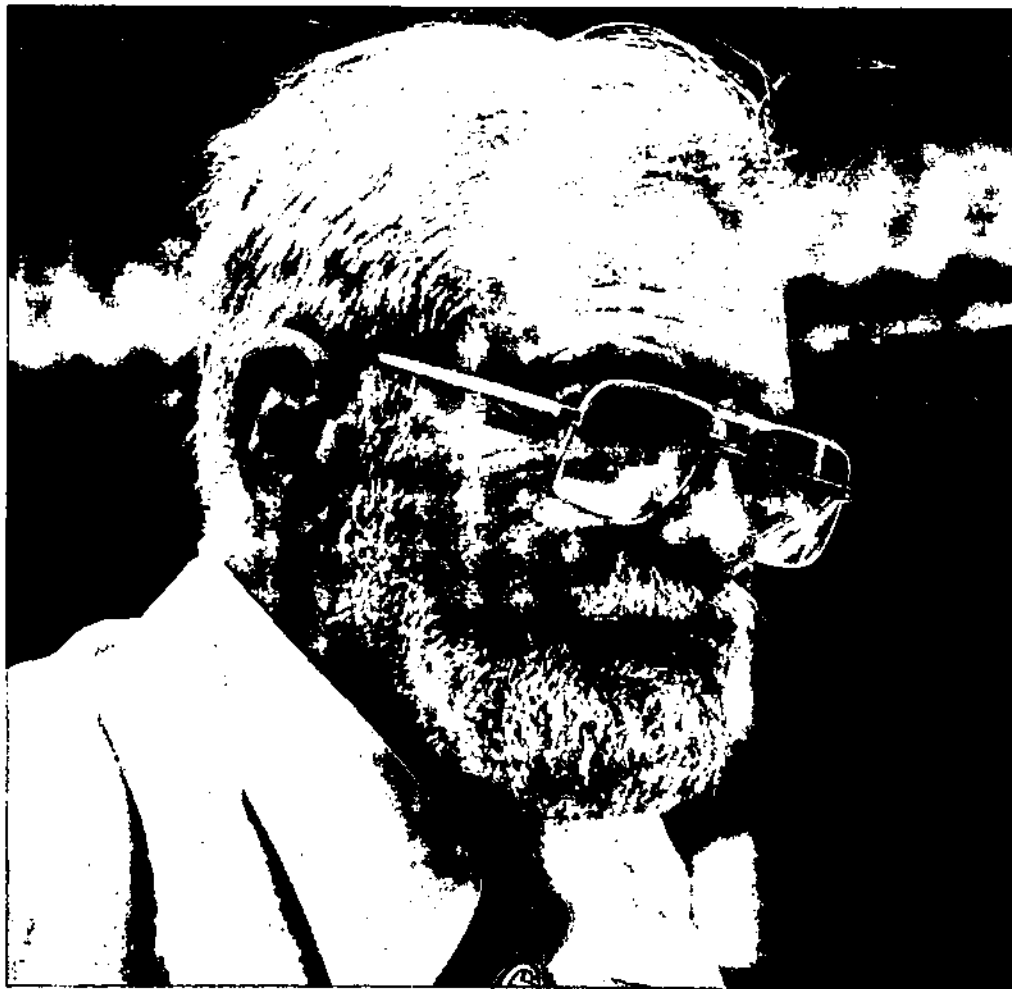

**CLOSE ENCOUNTER  
WITH DR. J. ALLEN HYNEK**

**MUFON UFO JOURNAL**  
 (USPS 002-970)  
 (ISSN 0270-6822)  
 103 Oldtowne Rd.  
 Seguin, Texas 78155-4099

**DENNIS W. STACY**  
 Editor

**WALTER H. ANDRUS, JR.**  
 International Director and  
 Associate Editor

**THOMAS P. DEULEY**  
 Art Director

**MILDRED BIESELE**  
 Contributing Editor

**ANN DRUFFEL**  
 Contributing Editor

**TED BLOECHER**  
**DAVE WEBB**  
 Co-Chairmen,  
 Humanoid Study Group

**PAUL CERNY**  
 Promotion/Publicity

**MARGE CHRISTENSEN**  
 Public Relations

**REV. BARRY DOWNING**  
 Religion and UFOs

**LUCIUS FARISH**  
 Books/Periodicals/History

**ROSETTA HOLMES**  
 Promotion/Publicity

**GREG LONG**  
 Staff Writer

**SIMONE MENDEZ**  
 Staff Artist

**TED PHILLIPS**  
 Landing Trace Cases

**JOHN F. SCHUESSLER**  
 Medical Cases

**LEONARD STRINGFIELD**  
 UFO Crash/Retrieval

**WALTER N. WEBB**  
 Astronomy

**NORMA E. SHORT**  
**DWIGHT CONNELLY**

**DENNIS HAUCK**

**RICHARD H. HALL**

**ROBERT V. PRATT**

Editor/Publishers Emeritus

The MUFON UFO JOURNAL is published by the Mutual UFO Network, Inc., Seguin, Texas. Membership/Subscription rates: \$15.00 per year in the U.S.A.; \$16.00 foreign in U.S. funds. Copyright 1984 by the Mutual UFO Network. Second class postage paid at Seguin, Texas. POSTMASTER: Send form 3579 to advise change of address to The MUFON UFO JOURNAL, 103 Oldtowne Rd., Seguin, Texas 78155.

# FROM THE EDITOR

Is it just my imagination, or are things heating up in the UFO field? Certainly it seems like there is more happening every month than we are able to cram into each issue of the Journal! Still, we are doing our best (and that's a collective best) to bring you both the best and the most up-to-date news in the world of ufology. We like to think we earn your respect and subscription the old fashioned way: by earning it. But we'll never know if you don't tell us, so please let us hear your comments and criticisms.

In the meantime.....Jerome Clark, associate editor at FATE magazine, is the new editor of the International UFO Reporter. He will have a review of SKY CRASH in the April issue of FATE. Walt Andrus will soon be giving us an update of Lucius Farish's role in the same Rendlesham Forest affair and we also hope to have a progress report by Jenny Randles, one of the original authors.

In the immediate future we can look forward to the St. Louis MUFON Symposium (make your reservations now) and National UFO Week, both scheduled for this summer and both worthy of your support. Meanwhile, between this issue and the next we have lots to offer, including my own interview with Dr. J. Allen Hynek, articles by Michael Swords and James McCampbell, artwork by Simone Mendez, a clever cartoon or two by Leonard Bruce, and letters by your, our readers.

## In this issue

INTERVIEW WITH DR. J. ALLEN HYNEK, by Dennis Stacy.....	3
UFONAUTS: HOMO SAPIENS OF THE FUTURE? by Michael Swords	7
STARS & PLANETS by Walter N. Webb .....	13
HUM'N'WHISTLE A UFO TUNE by James McCampbell .....	14
CARTOON by Leonard Bruce .....	18
DIRECTOR'S MESSAGE by Walt Andrus .....	20
COVER PHOTOGRAPH by Dennis Stacy	

The Mutual UFO Network, Inc. is exempt from Federal Income Tax under Section 501(c)(3) of the Internal Revenue Code. MUFON is a publicly supported organization of the type described in Section 509(a)(2). Donors may deduct contributions from their Federal income tax. In addition, bequests, legacies, devises, transfers, or gifts are deductible for Federal estate and gift tax purposes if they meet the applicable provisions of Sections 2055, 2106, and 2522 of the code.

The contents of the MUFON UFO JOURNAL are determined by the editor, and do not necessarily represent the official position of MUFON. Opinions of contributors are their own, and do not necessarily reflect those of the editor, the staff, or MUFON. Articles may be forwarded directly to MUFON. Responses to published articles may be in a Letter to the Editor (up to about 400 words) or in a short article (up to about 2,000 words). Thereafter, the "50% rule" is applied: the article author may reply but will be allowed half the wordage used in the response; the responder may answer the author but will be allowed half the wordage used in the author's reply, etc. All submissions are subject to editing for style, clarity, and conciseness.

Permission is hereby granted to quote from this issue provided not more than 200 words are quoted from any one article, the author of the article is given credit, and the statement "Copyright 1984 by the Mutual UFO Network, 103 Oldtowne Rd., Seguin, Texas" is included.

# CLOSE ENCOUNTER WITH DR. J. ALLEN HYNEK

by  
DENNIS STACY

## AN INTERVIEW WITH THE DEAN

For over two decades, from 1948 to 1969, Dr. J. Allen Hynek was a consultant in astronomy to the United States Air Force. The subject of his advice, however, was not the fledgling space program or even the moon and stars above, but Unidentified Flying Objects, UFOs, or "flying saucers," as they were popularly called: those ghostly lights that went zip in the night and generally scared the hell out of a populace still suffering World War II shellshock and confronting the atom bomb, while peering anxiously into the future of Cold War politics.

As a scientist, Hynek's credentials were unassailable. In 1935, he had received his doctorate in astrophysics from the University of Chicago and moved directly into his first teaching position at Ohio State University. He was an astronomer at the University's Perkins Observatory when he was recruited by the Air Force. Later, Hynek would be a Visiting Professor at Harvard, Chief of the Section of Upper Atmosphere Studies and Satellite Tracking, and the Associate Director of the Smithsonian Astrophysical Observatory. From 1960 until his retirement from academia in 1975, he was Chairman of the Department of Astronomy and Director of Dearborn Observatory, Northwestern University.

As a UFO skeptic, however, Hynek turned out to be a complete flop. His experiences with Air Force Projects Sign, Grudge and Blue Book inevitably convinced him that there was more to the UFO phenomenon than could be handily swept under the carpet of private secrecy and public ridicule that was military policy. In short, he became a "believer."

Hynek's Road to Damascus has hardly been smooth and paved with money, however, as the following interview reveals. He has had to suffer his own share of peer ridicule and economic stress in a search for



DR. J. ALLEN HYNEK

-Dennis Stacy

answers.

In 1972, drawing on his Blue Book experiences and copious files, Hynek published *The UFO Experience: A Scientific Inquiry*, containing his classification of UFO encounters, the Third Kind of which Stephen Spielberg later branded indelibly in the public mind. In 1973, he founded the Center for UFO Studies (CUFOS) and today serves as Director and the editor of its journal, "International UFO Reporter."

**STACY:** Dr. Hynek, as a scientist, you go back as far with the UFO phenomenon as probably anyone alive today. Exactly how did that relationship begin?

**HYNEK:** That's an easy story to tell. In the spring of 1948, I was teaching astronomy at Ohio State University, in Columbus. One day three men, and they weren't dressed in black, came over to see me from Wright-Patterson Air Force Base in nearby Dayton. They

started out by talking about the weather, as I remember, and this and that, and then finally one of them asked me what I thought about "flying saucers."

I told them I thought they were a lot of junk and nonsense and that seemed to please them, so they got down to business. They said they needed some astronomical consultation because it was their job to find out what these flying saucer stories were all about. Some were meteors, they thought, others stars and so on, so they could use an astronomer. What the hell, I said, it sounded like fun and besides, I would be getting a top secret security clearance out of it, too.

At that time, it was called Project Sign, and some of the personnel at least were taking the problem quite

(continued next page)

## HYNEK, Continued

seriously. At the same time a big split was occurring in the Air Force between two schools of thought. The serious school prepared an estimation of the situation which they sent to General Vandenburg, but the other side eventually won out and the serious ones were shipped off to other places. The negatives won the day, in other words.

My own investigations for Project Sign added to that, too, I think, because I was quite negative in most of my evaluations. I stretched pretty far to give something a natural explanation, sometimes when it may not have really had it. I remember one case from Snake River Canyon, I think it was, where a man and his two sons saw a metallic object come swirling down the canyon which caused the tops of the trees to sway.

In my attempt to find a natural explanation for it, I said that it was some sort of atmospheric eddy. Of course, I had never seen an eddy like that and had no real reason to believe that one even existed. But I was so anxious to find a natural explanation because I was convinced that it had to have one that, naturally, I did. In fact, it wasn't until quite some time had passed that I began to change my mind.

**STACY:** Was there ever any direct pressure applied by the Air Force itself for you to come up with a conventional explanation to these phenomena?

**HYNEK:** There was an implied pressure, yes, very definitely.

**STACY:** In other words, you found yourself caught, like most of us, in a situation of trying to please your boss?

**HYNEK:** Yeah, you might as well put it that way, although at the same time I wasn't going against my scientific precepts. As an astronomer and physicist, I simply felt *a priori* that everything had to have a natural explanation in this world. There were no ifs, and or buts about it.

The ones I couldn't solve, I thought if we just tried harder, had a really proper investigation, that we probably would find an answer for. My batting average was about 80 per cent and I

figured that anytime you were hitting that high, you were doing pretty good.

That left about 20 per cent unsolved for me, but only about three or four per cent for the Air Force, because they used statistics in a way I would never have allowed for myself. For example, cases labeled as "insufficient information" they would consider solved!

They also had some other little tricks. If a light were seen, they would say, "aircraft have lights, therefore, probable aircraft." Then, at the end of the year, when the statistics were made up, they would drop the "possible" or "probable" and simply call it an aircraft.

**STACY:** What began to change your own perception of the phenomenon?

**HYNEK:** Two things, really. One was the completely negative and unyielding attitude of the Air Force. They wouldn't give UFOs the *chance* of existing, even if they were flying up and down the street in broad daylight. Everything *had* to have an explanation. I began to resent that, even though I basically felt the same way, because I still thought they weren't going about it in the right way. You can't assume that everything is black no matter what.

Secondly, the caliber of the witnesses began to trouble me. Quite a few instances were reported by military pilots, for example, and I knew them to be fairly well-trained, so this is when I first begin to think that, well, maybe there is something to all this.

The famous "swamp gas" case which came later on finally pushed me over the edge. From that point on, I began to look at reports from a different angle, which was to say that some of them could be true UFOs.

**STACY:** As your own attitude changed, did the Air Force's attitude toward you change, too?

**HYNEK:** It certainly did, quite a bit, as a matter of fact. By way of background, I might add that the late Jim McDonald, a good friend of mine who was then an atmospheric meteorologist at the University of Arizona, and I had some fairly sharp words about it. He used to accuse me very much, saying you're the scientific consultant to the Air Force, you should be pounding on generals' doors and

insisting on getting a better job done. I said, Jim, I was there, you weren't. You don't know the mindset.

They were under instructions from the Pentagon, following the Robertson Panel of 1953, that the whole subject had to be debunked, period, no question about it. That was the prevailing attitude. The panel was convened by the CIA, and I sat in on it, but I was not asked to sign the resolution. *Had* I been asked, I would not have signed it, because they took a completely negative attitude about everything.

So when Jim McDonald used to accuse me of a sort of miscarriage of scientific justice, I had to tell him that *had* I done what he wanted, the generals would not have listened to me. They were already listening to Donald Menzel and the other boys over at the Harvard Astronomy Department as it was.

**STACY:** Did you think you would have been shown the front door and asked not to come back?

**HYNEK:** Inside of two weeks I imagine. You're familiar with the case of Tycho Brahe and Johannes Kepler from the history of astronomy? Brahe had the observations and didn't know what to do with them, and Kepler, who was nearsighted and couldn't make the observations, did. So essentially, I played Kepler to the Air Force's Tycho Brahe. I knew the Air Force was getting the data and I wanted a look at it, so I made very full use of the copying machines at Wright-Patterson. I kept practically a duplicate set of records because I knew that someday that data would be worth something.

Toward the end, however, I was barely speaking with Major Quintanilla, who was in charge. We had started as really good friends and then things got very bad because he had one lieutenant who was such a nincompoop, it seemed to me. Everything *had* to be Jupiter or Venus, or this or that. You have no idea what a closed mind, what a closed attitude it was. I kept doggedly on, but I can safely say that the whole time I was with the Air Force we never had anything that resembled a really good scientific dialogue on the subject.

(continued next page)

## HYNEK, Continued

**STACY:** They weren't really interested in an actual investigation of the subject then?

**HYNEK:** They said they were, of course, but they would turn handsprings to keep a good case from getting to the attention of the media. Any case they solved, they had no trouble talking to the media about. It was really very sad.

I think their greatest mistake in the early days, however, was not turning it over to the universities or some academic group. They regarded it as an intelligence matter and it became increasingly more and more embarrassing to them. After all, we paid good tax dollars to have the Air Force guard our skies and it would have been bad public relations for them to say, yes, there's something up there, but we're helpless. They just couldn't do that, so they took the very human action of protecting their own interests. What they said was that we solved 96 per cent of the cases and that we could have solved the other four per cent if we had just tried harder.

**STACY:** Was it the famous Michigan sightings of 1966, explained away as "swamp gas" that finally did lead the Air Force to bring in a reputable university?

**HYNEK:** Yes, that, as you know, became something of a national joke and Michigan was soon being known as the "Swamp Gas State." Eventually, it resulted in a Congressional Hearing called for by then state Congressman, Gerald Ford, who of course later went on to become President. The investigation was turned over to the Brian O'Brien Committee who did a very good job. Had their recommendations been carried out, things might have turned out much better than they did.

They recommended that UFOs be taken away from the Air Force and given to a group of universities, to study the thing in as wide a way as possible. Well, they didn't go to a group, they went to a university and a man they were certain would be very hard-nosed about it, namely, Edward Condon at the University of Colorado. That was how the Condon Committee and

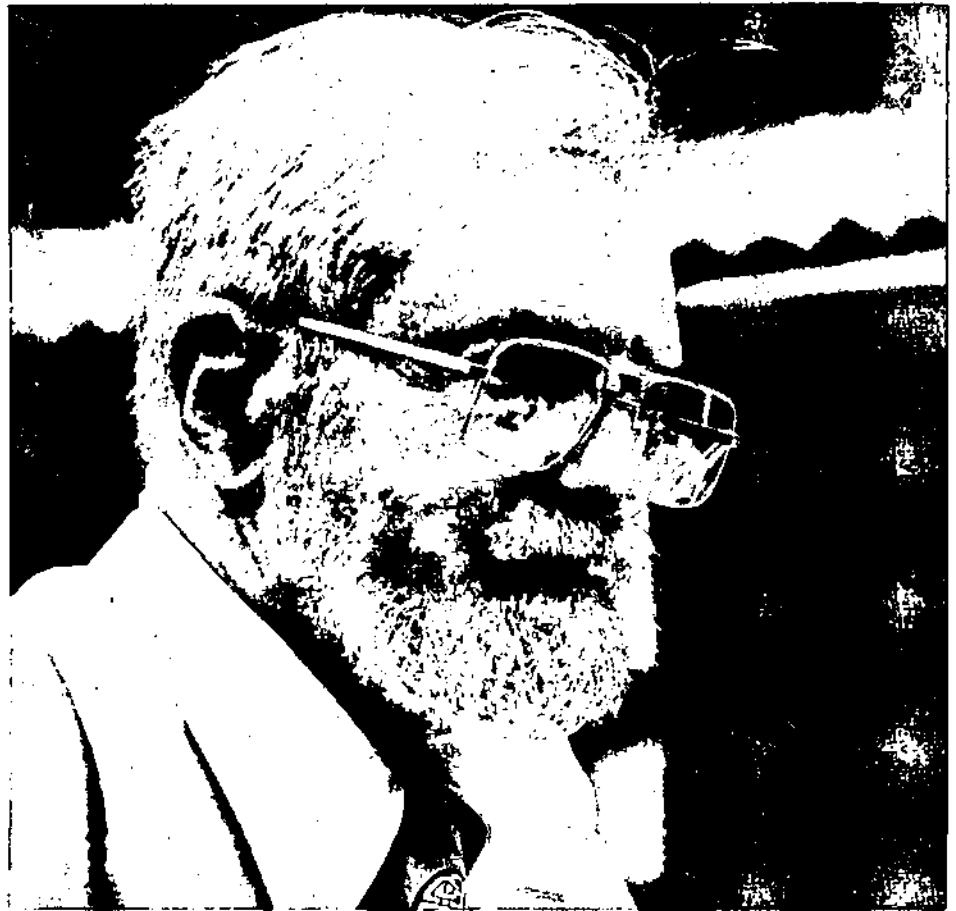

DR HYNEK

*-Dennis Stacy*

eventually the Report came to be.

**STACY:** Were you ever called on to testify before, or advise the Committee?

**HYNEK:** In the early days they called on me to talk to them, to brief them, but that was the extent of it. They certainly didn't take any of my advice.

**STACY:** By 1968, the generally negative Condon Report was made public and the Air Force used its conclusions to get out of the UFO business. Were you still an official advisor or consultant at that time?

**HYNEK:** Oh, yes, I was with the Air Force right up until the very end, but it was just on paper. No one had cut the chicken's heat off yet, but the chicken was dead. The last days at Blue Book were just a perfunctory shuffling of papers.

**STACY:** In terms of the UFO phenomenon itself, what was going on about this time?

**HYNEK:** Well, as you know, the Condon Report said that a group of scientists had looked at UFOs and that

the subject was dead. The UFOs, of course, didn't bother to read the report and during the Flap of 1973, they came back in force.

It was at that time that I just got totally disturbed. It seemed to me that from the scientific point of view a lot of data was being lost, washing down the drain. Nobody was minding the store anymore. So instead of just waving my hands in the air, I said let's do something and make a Center for UFO studies.

And in that year, 1973, I wrote to the three existing UFO organizations pointing out that the Center was to be an association of scientists to study the subject and that we had no field investigators of our own. We did have a police UFO hotline, however, that Northwestern University had helped us set up, and I said that I would like to do it this way: that whenever we got a good report, we would call one of the UFO organizations with the closest

*(continued next page)*

## HYNEK, Continued

investigator. Their man would then go into the field, investigate, and file a report with the parent organization. All we wanted in turn was a copy of the report for our own files. I didn't want an organization that would be in competition with the others. Since then we've added a few investigators of our own, probably less than a hundred altogether.

What happened then, though, was kind of interesting. The Aerial Phenomena Research Organization, (APRO) was afraid that we would turn their list of field investigators over to the Mutual UFO Network (MUFON), which was a splinter group at that time; and the National Investigation Committee on Aerial Phenomena (NICAP) said, sorry, but according to our charter, NICAP investigators can report only to NICAP. Walt Andrus, of MUFON, was the only one to see the light and say, yes, he would do it. But even he had a hard time getting it past his Board of Directors.

**STACY:** Probably your biggest contribution to the public's awareness of the UFO phenomenon was your classification system, culminating in the Stephen Spielberg box-office smash movie, "Close Encounters of the Third Kind." How did you come to arrive at such a system?

**HYNEK:** About 1970, right after the Air Force fiasco, I thought it would be interesting to write up some of my experiences. In writing up the Air Force cases I first of all divided them into two separate groups. I wasn't going to assume any kind of classification that would depend on a theory of origin. I wanted something that was completely *observational* in nature.

Well, the first obvious observation was, did you see it far away from you or close up to you? I chose to call near sightings, say within 500 feet, Close Encounters. Then quite naturally the Close Encounters divided themselves into three groups. There were those that were close, but didn't do anything; those that were close and did do something; and those that were close and had creatures in them or around them. So I now had Close Encounters of the First, Second and Third Kinds. I

didn't think the classification would take off and fly like it did; it was mostly for my own edification, a way of separating the cases I had.

**STACY:** How did the movie itself arise? Did Spielberg call you up and ask to use the name?

**HYNEK:** No, the other way around actually. I'd heard that Spielberg was making a movie called "Close Encounters of the Third Kind," so I called him up and we had a very nice talk. He apparently wanted to make some kind of financial arrangement with me and here I made a very bad mistake. Unfortunately, I said "Be my guest." Of course it's impossible to copyright a title alone, so he didn't pay a thing for its use. He was kind enough, however, to ask me to be technical consultant to the movie, so that worked out very well.

**STACY:** You received a fee for that work, then?

**HYNEK:** A very small fee, but I actually lost money on that. What happened was that my publisher withheld \$25,000 in royalties from the sale of my book, *The UFO Experience: A Scientific Inquiry*. The argument was that I had sold the movie rights to Hollywood. I pointed out that I might be a dumb professor, but I wasn't so dumb as to know you don't sell movie rights for a thousand dollars. Finally, the thing

was settled with me getting \$15,000 and paying \$9,000 legal fees out of that, so I didn't get very much. Some people think I made a lot of money out of the movie, but I didn't. I lost.

**STACY:** What was your opinion of the final product?

**HYNEK:** Spielberg, of course, had his own mind and knew what he wanted to do and I was only a technical consultant, remember. I gave advice about the radio telescope and how a military officer would say things one way as opposed to another, and those sorts of little details.

We sat down and went over the script together and chatted back and forth about it. At that time I didn't like the opening, the part about finding the lost flight of Navy Avengers in the desert and so on. But when the movie came out, it was a marvelous, dramatic opening, what with the wind and noise and all.

As I pointed out to myself and others, though, the movie didn't presume to be a documentary, it was Hollywood entertainment. Some people criticized me for having to do anything with it at all, saying that it would hurt my scientific image. At that time I was kind of caught up in the glamor of Hollywood myself, seeing how a picture was made, so I went along with it and I had a lot of fun. But that's about all.



EDITOR DENNIS STACY

# UFONAUTS: HOMO SAPIENS OF THE FUTURE?

by MICHAEL D. SWORDS

## ABSTRACT

Current evolutionary theory now sees the possibility of dramatic changes in structural appearance due to small changes in *regulatory genes* (those genes which control the rates of growth and development). This concept has reinstated the theory of "Man as Fetal Ape" as the leading hypothesis for explaining the change of form from ape-like to human. By projecting a similar structural shift in our future, it is possible to construct a picture of a potential next stage in human evolution. This potential "descendent species" is strikingly reminiscent of the occupants in most of the well documented close encounter and abduction cases in ufology. If the "ufonauts" were to turn out to be future forms of Homo Sapiens, then many mysteries in the UFO phenomenon would disappear.

## THE "NEW" HUMAN THEORY

Ape. Ape-man. Man-ape. Man. How did we really come to be? Oddly, the answer to this question may reflect upon not only ourselves but upon the UFO mystery as well.

Everyone is familiar with the standard conception of the evolution of our species from extinct ape-like ancestors. It seems as though every other month some palaeontologist discovers the chart of our heritage. But gaps and questions still remain. All across the fossil record, in fact, there seem to be "moments" of jumps in biological forms. It is as if evolution cruised along quietly for tens of thousands of years and then, BANG!, an abruptly changed structure arose. This realization has convinced many biologists that episodes of rapid structural change are commonplace in Earth's history, and the new theory is called "punctuated equilibrium." But what is the case?

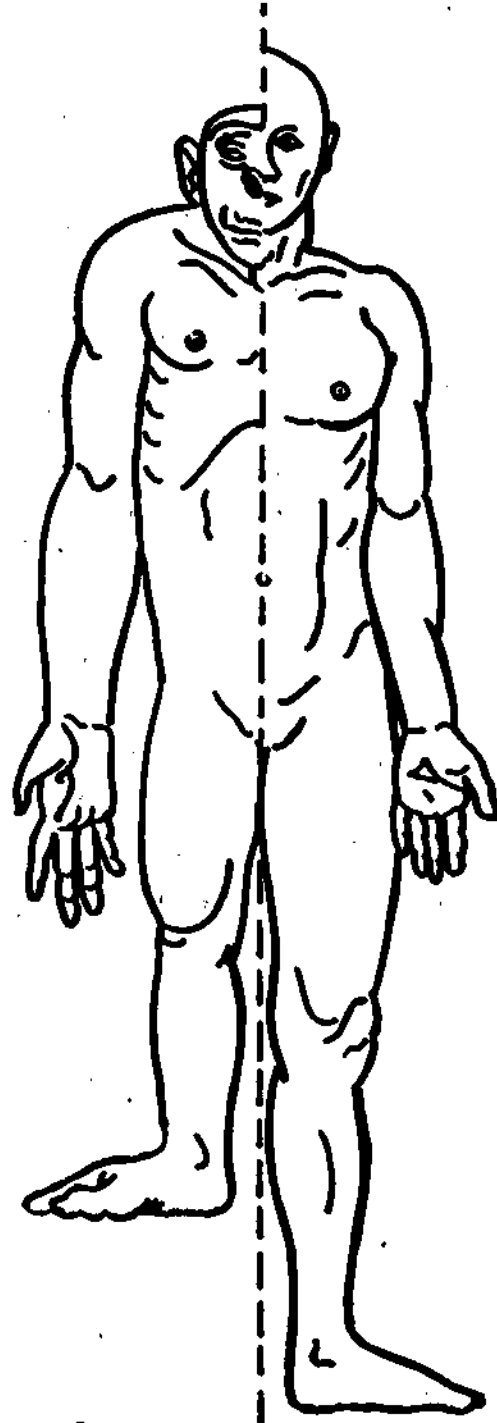

Figure I:  
Although human and great ape genes are 99% identical, the structural forms differ markedly. (Drawing in imitation of that by S.L. Washburn, U. Cal., Berkeley).

(continued next page)

## UFONAUTS, Continued

When we compare the human form to that of our nearest genetic "cousin" on Earth, the chimpanzee, we see many similarities of course. But there are significant differences as well. And yet when we compare ourselves genetically to the chimps we are nearly identical. As someone has recently phrased this: the genes fit, but the bodies do not (see figure one). How can this be? How can we have nearly identical structural genes, yet quite large structural differences in some areas of our bodies? The answer, it seems, is "neoteny." And this is one of the genetic tricks by which Nature can produce leaps of structural difference, "punctuated equilibrium."

In the 1920's anatomist Louis Bolk was struck by the similarities in structure not of humans and chimpanzees, but of humans and fetal chimpanzees. Almost all the easily recognized physical differences between ourselves and the apes are much much closer when comparing our forms with embryonic ape forms. Bolk's conclusion: Homo Sapiens is,

physically, a fetal ape, which has become sexually mature (see figure two).

This phenomenon of a "fetal" or "larval" form of species bypassing the normal physical development and becoming sexually mature turns out to be quite common in animals even today. Many species of amphibians are capable of it due to simple temperature changes in the lakes wherein they breed. Sometimes the changes are permanent, and a seemingly brand new physical form pops up on the ecological landscape from "nowhere." This "retention of fetal or ancestral characteristics in some organs" is Neoteny. It is a change *not* in gene structures, but in the mechanisms that govern the rates of their functions. Thus creatures with the same genes, but working at different rates, can appear remarkably dissimilar.

### FUTURE EVOLUTION?

Since neoteny seems the major candidate for explaining the coming-to-be of humans from the past, what might be predicted for the coming-to-be of

humans in the future? Will the Arrow of Evolution continue to alter our structure? Or will our technology negate its effects? Without being able to predict the future of our struggle to adjust to our own inventions, it is impossible to say whether "natural" selection will continue to operate on the human species. But we could look at our fetal forms and speculate as to the potential for structural change resident there, and whether some of those changes might be valuable.

As we have seen some of the major changes of past neoteny evolution from apes to humans have involved the brain and the features of the face. Comparing these features in adult humans and human fetuses, we note the following:

- 1) The brain of the fetus is again larger in proportion to the body than that of the adult;
- 2) The cranium to contain the brain is again more domed and prominent;
- 3) The eyes have remained large, but the nose, mouth, and ears are diminished;

(continued next page)

Figure 2

Normal chimpanzee development

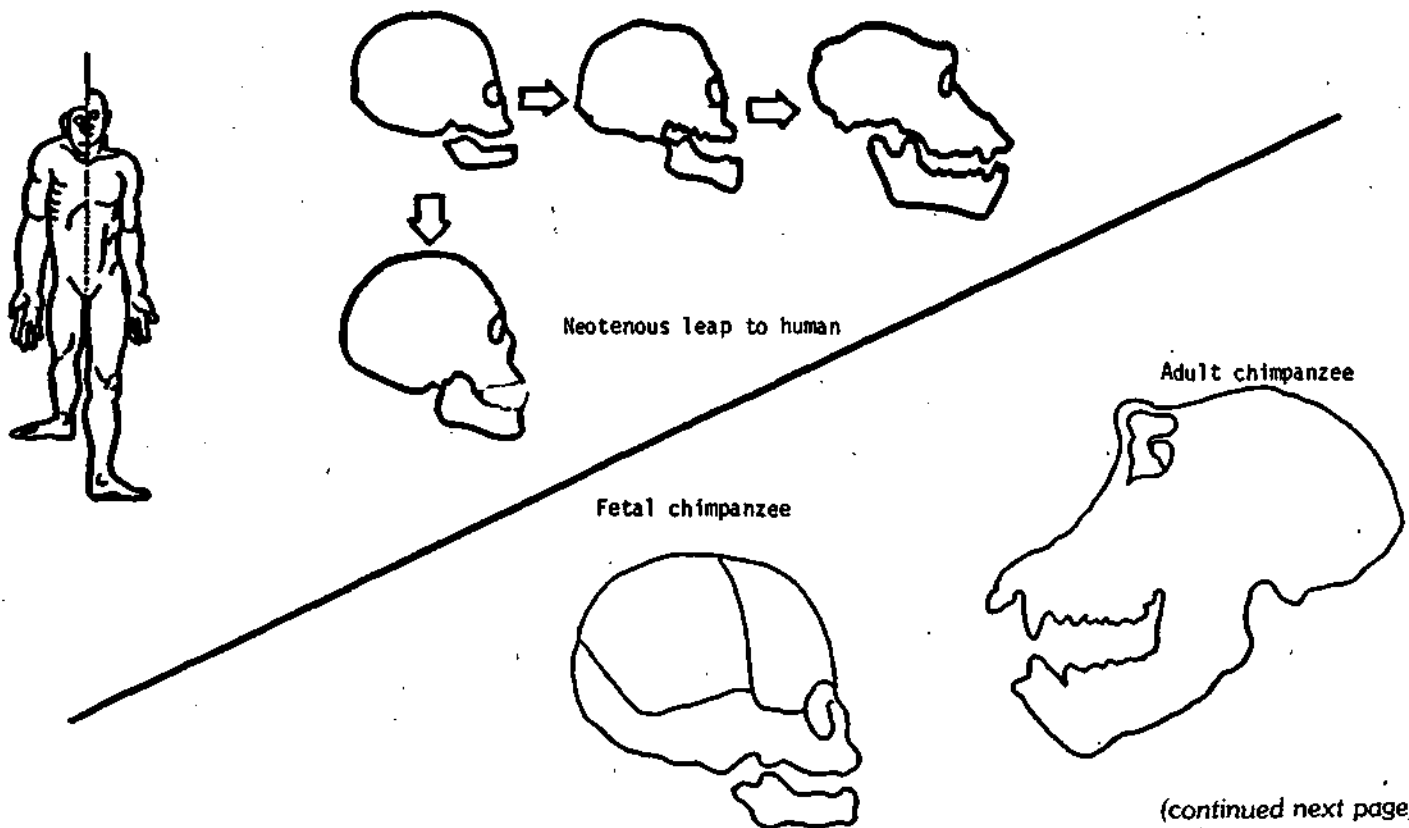

(continued next page)

## UFONAUTS, Continued

Figure 3

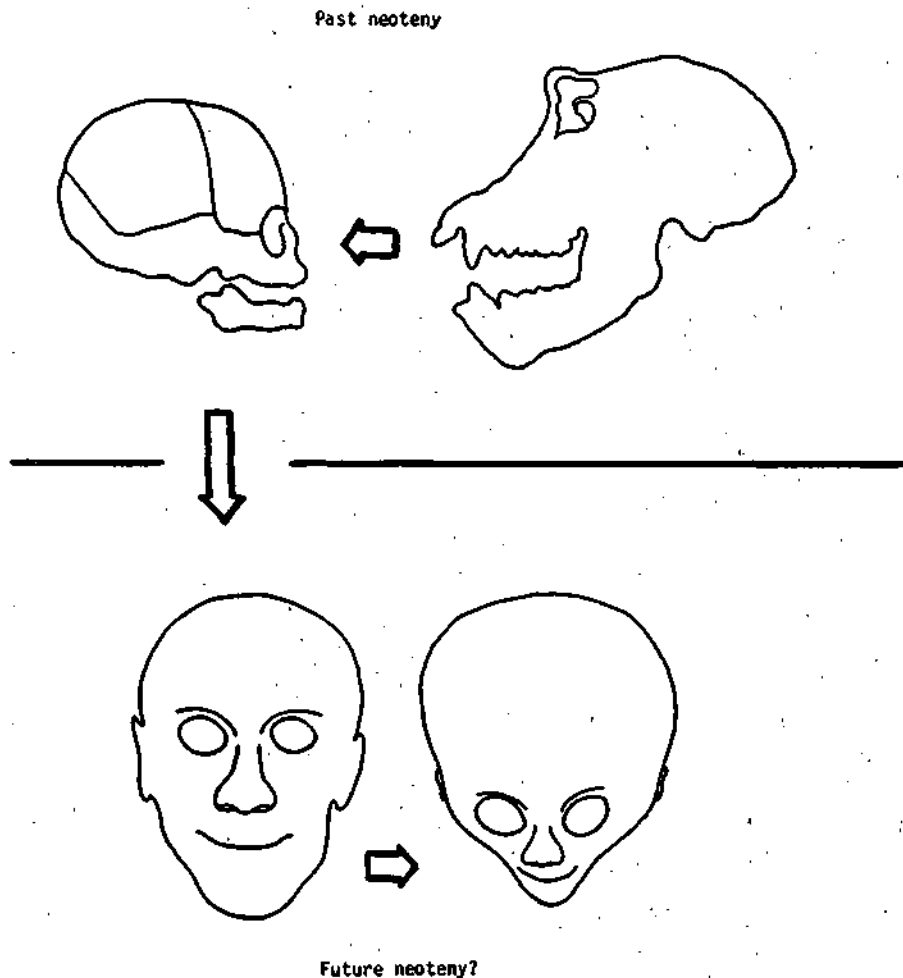

4) The jaw and chin bones are smaller, and the bones of the cranium less massive (see figure three).

Elsewhere in the body, we find that many of the changes of ape-to-man seem to have gone as far as they can or will go. For example, comparing adult humans and fetuses:

- 1) the thumb is readily opposable in both adult and fetal human; the big toe is not;
- 2) the positioning of the skull on the vertebral column is such to allow straight-standing, eyes-front posture in both;
- 3) the positioning of the pelvic girdle attachment is appropriate for straight-standing as well;
- 4) the proportions of limb lengths to trunk length seem to be relatively the same.

Other changes in structure and appearance lead us into the morass of the effects of the pituitary, since this

gland is intimately involved with gene-regulation mechanisms (regulation of growth rates) via its hormones and the systems throughout the body, which they affect.

1. Concerning stature: since we are tall relative to most apes, we think of our evolutionary leap as bringing tallness with it. It didn't. In fact, alterations of growth toward a more fetal type might be expected to reduce height, at least initially. Why? Because we're envisioning a more rapid rate of sexual maturity vs. physical robustness, and the puberty hormones signal that the end to long bone growth is coming in humans. Our early ancestors, it is known, were short. They averaged 112.5 cm ( 3-ft. 8 inches) in height. Our subsequent growth at least partially reflects pituitary gland malfunction of current humanity may be relevant here: congenital isolated growth hormone

deficiency, also known as "sexual ateliotic dwarves." These individuals have a block in the effectiveness (i.e. a rate-regulating problem) of pituitary growth hormone (somatotropin). It causes dwarfing (individuals of 2 ft. 11 inches to 3 ft. 11 inches high) with near normal body proportions and disproportionately large (though not "fetal") heads. They do mature sexually and can reproduce. This is quite near to a neotenus gene-regulatory phenomenon involving perhaps only one gene. It would seem to indicate that a neotenus jump of the type speculated upon above is well within the potential of the human gene pool. And it may focus upon the 3 to 4 foot stature level as the probable first approximation as to the expected height of the new form (see figure five).

2. Skin characteristics: if you ransack the medical literature looking at the effects of altering the pituitary function, you find many effects which are lethal. It seems obvious and justifiable to toss these in the garbage and not litter our discussion, since, if the changes we're imagining included "killer" problems, such "variations" would never survive. It would be an evolutionary loser and be eliminated immediately. Only combinations of traits which can survive need interest us. One common characteristics which changes in pituitary-related diseases which probably no longer need be lethal or even hazardous in a technological world involves skin pigment. Both in hypophysectomy (removal of the pituitary) and Simmonds Disease (a pituitary dysfunction problem), as well as a related thyroid gland problem (Myxedema), the skin loses pigment. Very pale, almost albino-like skin is a common theme. Along with the paleness, the texture of the skin often changes as well. The skin becomes dry; sometimes puffy; sometimes waxy. The amount of superficial body hair diminishes and becomes finer. These effects are largely true in the fetus itself, of course.

3. Some miscellaneous characteristics: most of the other pituitary-related changes in these defects are obviously "out" as far as evolution is

(continued next page)

## UFONAUTS, Continued

<u>Apes</u>	<u>Human Form</u>	<u>Human fetus - Future Human?</u>
large cortex	increased (2 x)	ratio increased
large cranium	increased	ratio increased
partly domed	more domed	more domed yet
heavy jaw	lessened	lessened further
large lower face	lessened	lessened further
large ears	lessened	lessened further
head forward	more upright	sl. more so
much body hair	lessened	lessened further
long armed	shortened	approx. same
short legged	lengthened	shortened
thumb opposed	more so	same
big toe opposed	lessened	same
pelvis angled	more upright	same
massive bones	lessened	lessened further
long in womb	sl. increased	? <u>homo futuris</u> increased

TABLE I.

A comparison of Ape, Human, and Fetal features.

concerned (ex: senility, diabetes, hypoglycemia, adrenal cortex atrophy, emaciation and debility, etc). A few of the others might be tolerable, though.

A) Nitrogen-loss (less protein-storage, therefore less musculature). A technological species would be less dependent upon their own brute force and therefore might easily find a lighter build more energy efficient; maybe they'd even live longer.

B) Lower metabolic rate (and lower body temperature). Along the same lines, to a point this could be an advantage: As has been said of our life span "the hot clock ticks faster," and the hotter fire consumes itself more quickly (see table I).

### UFONAUTS AND ARTIFICIAL BIRTH

If close encounter witnesses are describing the "typical" small "fetoid" ufonauts accurately, and assuming that they really exist, then there is a serious biological problem with their form. This problem evaporates, however, if we envision the use of a hi-tech reproduction technology: artificial

wombs.

A biologist looks at our fetal-ufonaut and thinks: how did that ever get born? The large domed cranium seems far too big for the birth canal indicated by the pelvic width. There are only three scenarios which would allow this:

1) birth could occur "earlier" in brain and cranial development than it would in humans, thereby making the birth diameter of the head very small.

2) sexual dimorphism in ufonauts could be very great with the females (of which we must have seen none in the encounter cases) having very large pelvises proportionately;

3) natural delivery could never take place in this hi-tech civilization, and the large domed craniums would be a result of their liberation of their genetic potential from the limits of their small birth canals.

Scenario "1" is unsatisfying since it would birth a very incomplete being, requiring a lengthy post-birth vulnerability period. Scenario "2" is possible, even though it would be out-of-line for advanced "Earth-type" forms. It also probably requires a strict separation of male and female tasks in that civilization. Scenario "3" is not only

a feasible explanation of the structure, but is a technological development which might be considered likely even in our own civilization.

Why? In present day humans, it is theorized, fetal development proceeds for 9 months or so with the fetal brain consuming 50% of the total oxygen being sent by the mother during much of the pregnancy. Upon reaching a certain size, the mother can no longer supply sufficient oxygen and the fetal brain begins to mildly asphyxiate. As the fetus thrashes about (possibly sending chemical signals into the mother's blood) in protest of the insufficiency, the mother's system begins the birthing process. Over the millenia our species has matched this developmental phenomenon with the pelvic size of women and all turns out well.

But, there is ample evidence that human brain development during this fetal period could go much further. Modern nutrition and prenatal care is pushing fetal development along more quickly. Fetal heads are becoming too large for the birth canals of smaller women. Caesarian births are more common. As bio-science advances, this trend can only become more acute. There may easily be pressure to avoid the problems and the limitations on our brain's development by going to artificial wombs when they are developed. And once such cultural choices become commonly made, the doors to "artificial selection" and genetic engineering of the species are wide open.

### GENETIC ENGINEERING

We tend to think that even though we are willing to stock breed all our familiar animals in the extreme that we will never do likewise with ourselves. We may be kidding ourselves. The technologies of artificial insemination, test tube babies, sex predetermination and cloning are already largely in place. The science of genetic engineering is pursued more hotly than any area of basic research. When college students are asked whether they would use a cheap, safe and effective sex-choice technology almost half say they would.

(continued next page)

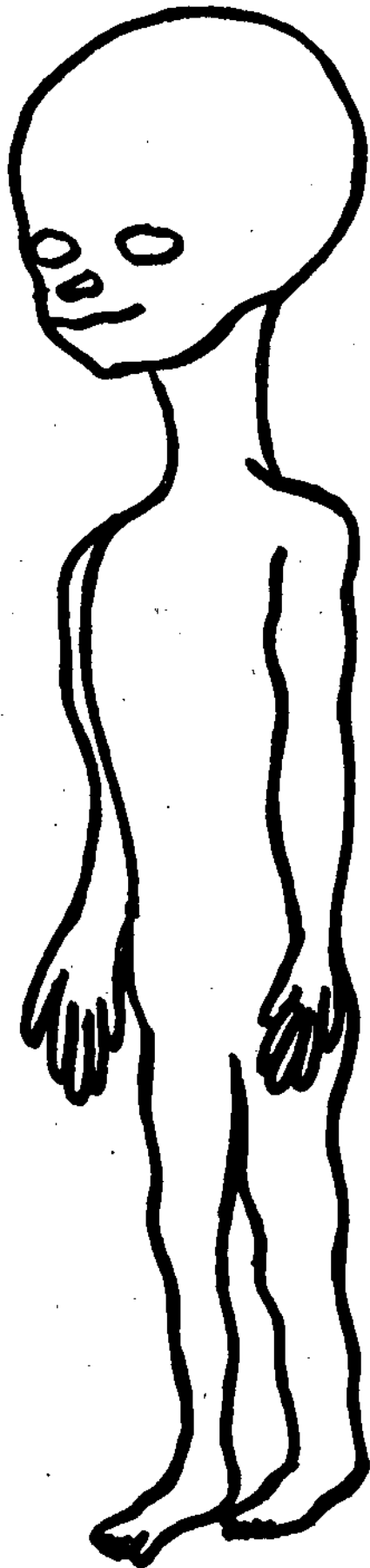

Figure 4

General proportions  
of the developed fetus

## UFONAUTS, Continued

And almost 100% of all parents would like their children to be healthy, bright, and good-looking. Controlling the genetic potential for these characteristics is well within our current concepts of genetic choice and engineering, even though the reality is not here yet. This author considers it highly probably that we will use these powers extensively in the future, rightly or wrongly.

As centuries go forward and technical complexity increases in our world, the pressure for selecting greater intelligence in our offspring might be inescapable. The genetic switch to our next "neotenus jump" in evolution might be seen as the proper course to take. Alongside this pressure an analogous march toward "perfect health" may well be going on. Once most major killers have been eliminated the choice to genetically select those individuals who are resistant to the remaining few fatal defects may be imperative. Why have a child with a 120 year life expectancy, when you could have one of 300 years? Very precise genetic reproduction, perhaps cloning (the simplest precise method), would be attractive and "logical." The point is this: with increased technology it becomes easier to rationalize genetic

choice in offspring and to accomplish it.

When drastic genetic change finally becomes a reality (ex: a neotenus artificial jump), the technology of the civilization would be so advanced as to allow certain qualities in the individual which would not be possible in a natural environment. For example:

A) the head-to-pelvis ratio that we have mentioned;

B) the diminution of sex-organs, secondary sex characteristics, and a general "unisex" look; these characteristics are sometimes seen in pituitary gland abnormalities today by the way. The sexual organs would not even have to be functional, since forms of genetic selection such as cloning do not require active sex cells; why a species would want to go unisex, of course, is a bit difficult for us "unevolved humans" to imagine;

C) In the fetus today the form of the larynx is incomplete, and if expressed in that form in an adult (through a neotenus shift) would probably eliminate normal speech and perhaps speech at all. A hi-tech civilization might make such a crucial loss irrelevant through technology, and of course, if telepathy exists, that ability would also make the loss of speech unimportant.

This picture paints a scene filled with reproductive and genetic

management. Such a species-wide program would be very likely to dramatically narrow the genetic diversity of the species, just as it does today in our agriculture. This is a dangerous game. If some factor in the environment changes, the entire species could be threatened. Or if some new need arose, the species may no longer contain the traits necessary to match it. If it was available, a convenient solution to these problems would be to go back to the genetic "roots," and harvest the cells of your pre-selection ancestors. A need to revitalize and expand the future "gene bank" would make meaning of some of the behaviors of the "abduction examinations." A need so great as to threaten the continuance of the species might make the risk of meddling in the past a reasonable choice to make.

### SUMMARY

What does the Neoteny Theory explain about the "ufonauts?"

- 1) Their facial features.
- 2) Their general build proportions.
- 3) Their lack of hair and pigmentation.
- 4) Their sex-organ diminution; and unisex look.
- 5) Their head-to-pelvis anomaly

(continued next page)

Figure 5

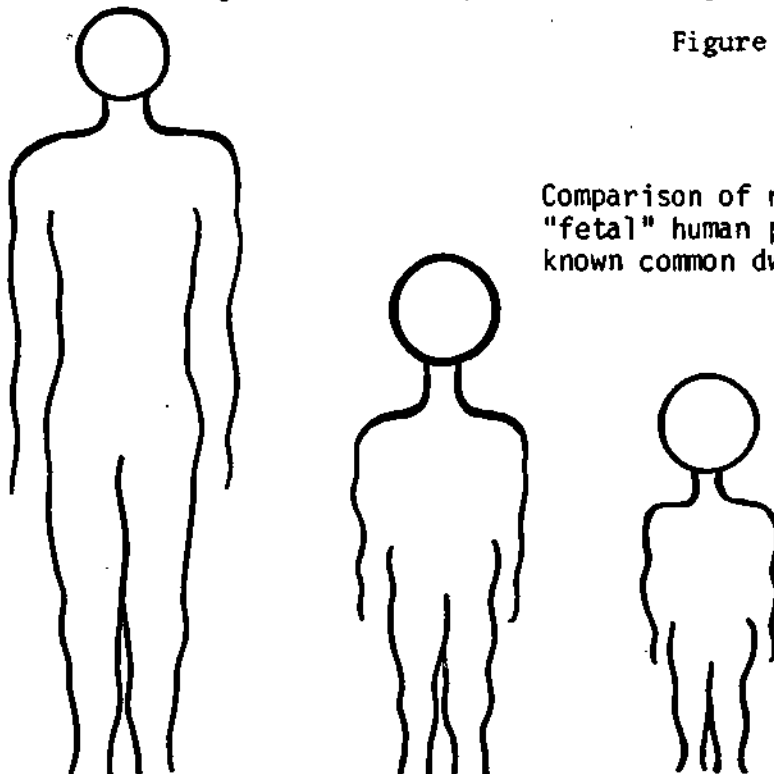

- (artificial birthing).  
 6) Their lack of normal speech.  
 7) Their abduction behaviors.  
 8) Their need not to interfere in obvious ways with their past.  
 9) Their need to create a sophisticated campaign of unreality (in order to ensure non-interference).  
 10) Their ability to breathe our (and their) atmosphere.  
 11) Their non-need to go great spatial distances (only to go *temporal* distances, which may involve no spatial involvement).  
 12) Their general interest in us (their ancestors).  
 13) Their possible association with — "old-style" (non-neotenus) *homo sapiens* in the same craft.

In sum, the idea has within it potential answers for all the commonest objections to ufo-anecdotal descriptions. But it brings up a pair of very large objections in their place, namely:

- 1) How in the world do you travel in time?, and is it even imagineable in a rational universe?
- 2) This theory is essentially post hoc, and those few things which it might predict are things which are likely never to be testable. This unfortunately condemns the theory scientifically, and consigns it ever to be a speculation... except for some lucky person with personal experience and internal knowledge of what may be going on.

So why bring this idea to the fore, if it is not likely to be testible? There is no requirement in *life* that all ideas be testible; only to be respectably *scientific* must this characteristic be present. Some ideas which fall beyond the abilities of the scientific method may nevertheless be true. It is just that science and confidence should not be built upon them. And, who knows, perhaps as the UFO phenomenon goes on, some bits and pieces of concrete evidence may piece together to unexpectedly support one of the several leading theories, including this one. If so, we may be able to say to our local USAF base commander:

Sir, we have met the aliens, and they are us.

# STARS & PLANETS

By Walter N. Webb  
 MUFON Astronomy Consultant

MARCH 1985

## Bright Planets (Evening Sky):

Venus begins the month high in the SW after sunset, still at its maximum magnitude of -4.3. But thereafter the brilliant planet moves rapidly toward the sun, setting earlier and earlier and finally disappearing into the solar glare by the end of the month.

The gap between Mars and Venus widens as the latter planet moves westward. Mars, much fainter than Venus, remains high in the SW, setting 3 hours after the sun in midmonth and a half hour after Venus. The red planet moves from Pisces into Aries.

Saturn, in Libra, rises in the SE around midnight on March 1 and by the end of the month, at 10 PM. The ringed planet appears to reverse direction on the 7th, turning westward for several months—an illusion caused by the earth catching up to the distant world and eventually passing it.

## Bright Planets (Morning Sky):

Jupiter, in Capricornus, is still low in the SE before sunrise but slowly brightening. It rises at 4 AM in midmonth, 2 hours before the sun comes up.

Saturn moves low across the southern sky and stands in the SW at sunrise.

## Moon Phases:

- Full moon--March 6
- Last quarter--March 13
- New moon--March 21
- First quarter--March 29

## The Stars:

During the midevening hours the bright stars of the Winter Circle are sliding into the west. The brightest nocturnal star, Sirius, appears in the SW. The springtime constellations are at last ascending the eastern heavens--Leo the Lion, Bootes the Herdsman, and Virgo the Maiden. The orange star Arcturus (in Bootes) is another of those objects that often cause false UFO reports when they are low in the sky (refraction effects). In midmonth this zero-magnitude luminary, fourth brightest nighttime star, rises in the NE about 7:30 PM.

## REFERENCES ON HUMAN EVOLUTION

1. Blechschmidt, Erich. *The Beginning of Human Life*. 1977
2. Campbell, B.G. *Humankind Emerging*. 1976
3. Capecchi, V. and M. Rigato. "Agility and Body Sturdiness of Primitive Man in Comparison with Contemporary Man," *J. Human Evolution* II: 441-5. 1982
4. Gribbin, John. "The 1% Advantage: human vs.

- gorilla," *Science Digest* August 1982, pp. 73-77.
5. Kolata, G.B. "Evolution of DNA: Changes in Gene Regulation" *Science* 189:446-7. 1975
6. Lavelle, C.L.B. R.P. Shellis, and D.F.G. Poole. *Evolutionary Changes to the Primate Skull and Dentition*. 1977
7. Miller, J.A. "Evolution: return of the embryo," *Science News* 120:12-14. 1981

# HUM' N' WHISTLE A UFO TUNE

by  
JAMES McCAMPBELL

In one of his classic books, Dr. Jacques Vallee presented summaries of 923 UFO landings that occurred between 1868 and 1968.<sup>1</sup> Small, human-like creatures were observed in many of the events that were considered in the context of mythological entities such as fairies, elves, and gnomes. But the collection of summaries was a gold mine of other details covering the full scope of the UFO experience, including UFO size, shape, structural details, luminosity, aerial performance, artifacts, electrical interference, and sounds.

Witnesses reported hearing some sounds in 103 instances. Their descriptions varied so widely that they initially made very little sense. But all the quotations were tabulated along with other details on large sheets of butcher paper by the present author. By using colored pencils to tie together statements that could easily be alternative ways of describing a sound, it was found that nearly all statements fell into five categories. These were descriptively labeled as Violent, Low Pitch, Rush of Air, High Pitch, and Signals.<sup>2</sup> Of present interest are the Low Pitch and High Pitch categories.

## WEIRD TUNES

Typical words describing a low-pitch tone were "buzz," "electric motor," "generator," "humming," and "humming bees." Such sounds are now so familiar that they have become almost an auditory signature of UFOs at short range. In the Vallee summaries, however, the high-pitch tone was reported somewhat more frequently with such expressions as "high speed drill," "shrieking," "shrill whir," and "piercing whistle." The italicized words specifically denote high pitch.

Every effort should be made to understand what the witnesses have attempted to describe and to relate that to the physical world in which they, and



JAMES McCAMPBELL

-Dennis Stacy

we, live. The repeated references to humming bees is clearly a useful clue. The humming sound from flying bees is produced by the beating of their wings at about 270 times per second.<sup>3</sup> That sound can be approximated by humming in tune with middle C on a piano (261.3 cycles/sec) or C# (277.18 cycles/sec). On the other hand, references to electrical apparatus are reminiscent of much lower tones associated with alternating current at the standard 60 cycles/sec.

In 1973, the author suggested that the low-pitch sound from UFOs might be stimulated by pulsed, microwave radiation.<sup>4</sup> Relatively little was known of the phenomenon at that time; however, medical experiments had shown that some people could hear modulated, radio-frequency energy that they interpreted as a "buzzing or knocking" sound. All the subjects felt that the

sound originated behind their heads regardless of the actual location.<sup>5</sup> Apparently, the pulsed energy bypassed the outer ear and induced signals directly in the auditory nerve. The physical reality of that mechanism had been demonstrated when micro-electrodes were inserted into a single nerve fiber with subsequent exposure to microwaves. Electrical potentials from millivolts up to 0.10 volts were measured between the inside and outside surface membranes.<sup>6</sup> Radar systems are typically pulsed at a few hundred cycles per second whereas the frequency of the radiation itself is in the range of 500,000,000 c/s. Because the upper limit of human hearing is around 20,000 c/s, it is obvious that the test subjects were hearing the pulses and not the carrier.

(continued next page)

## HUM'N'WHISTLE, Continued

### HUMAN HEARING

If a person sitting quietly in the woods hears a twig snap, he will instinctively turn his head and glance toward the source of the sound. This ability to pin-point the source is based upon a very small delay from the time that a sound wave reaches the nearer ear until it reaches the remoter ear, a process known as binaural audition. Without conscious effort, the brain in an instant miracle of computation accurately interprets the time difference in terms of the angle to the source. Clearly, the time of arrival would be the same from any source lying in a vertical plane through the bridge of the nose, that is, perpendicular to a line between the ears and intersecting it midway. The body has no mechanism to determine where on that plane a source may be. If something in the field of vision is the obvious source, it will be so interpreted. But if no source can be seen, it will likely be interpreted as coming from the rear.

Some laboratory tests with actual sound sources on that plane, however, reveal some curious details. It was found that tones in the frequency range from 500 to 2,000 c/sec seemed to come from the rear whereas tones of lower or higher frequencies were interpreted as coming from the front.

As the speed of microwaves is vastly greater than the speed of sound, 186,000 mi/sec compared to 0.21 mi/sec, the time delay for microwaves reaching both ears is practically zero. It is, therefore, no surprise that sounds generated by microwaves appear to come from behind the head. One would naturally suspect that the low pitch tone in UFO events may be caused by microwaves when the direction to the source is in doubt.

### MICROWAVE AUDITION

Extensive research on microwave hearing was conducted during the 1970s but the findings were broadly scattered in sources that are hard for the average citizen to obtain. It was necessary to purchase obscure documents, utilize a first-rate technical

library at a university or national laboratory, or rely upon inter-library loan services of the local library. But a thorough review of the subject is now available in a book, *Microwave Auditory Effects and Applications*.<sup>7</sup> Its author, James C. Lin, Ph.D., is eminently qualified to write such a book as he is Associate Professor of Electrical Engineering, Adjunct Professor of Physical Medicine and Rehabilitation at Wayne State University. He was formerly Assistant Professor of Rehabilitation Medicine and Assistant Director, Bioelectromagnetics Research Laboratory at the University of Washington School of Medicine. In addition to an excellent historical survey and evaluation of the research, he presents his own, original analyses and compares the theoretical predictions with experimental data. This information is of vital interest in the context of UFO sounds although probably not anticipated by Dr. Lin.

While the ear is a complex structure, it will suffice to say here only that hearing occurs in the inner ear where a small, spiral organ, known as the cochlea functions as a microphone. It converts pressure waves transmitted from the air through the outer ear into electrical signals that travel along the auditory nerve to the brain. By means not exactly understood they move hairs lining the supporting cell structure to the organ of Corti to initiate the electrical signals. The wave form of impinging sound is faithfully reproduced as an electrical wave form in the auditory nerve.

The following paragraphs will rely heavily upon the book by Dr. Lin and parentheses in the text will indicate where the information may be found. Original research reports can be easily tracked down in the extensive and well-referenced bibliography in the book. Example, (Lin, p 100).

### PULSED MICROWAVES

A number of parameters must be specified in order to describe a chain of microwave pulses completely. First, the frequency of the radiation must be known. Next, the manner in which the pulses are delivered is important, that is, the pulse rate. As a pulse rate can be

of any width that must also be stated. One can see that a strong but very short pulse followed by a relatively long interval before the next one would deliver only a small amount of power. Thus one speaks of pulse widths, peak powers, average powers, and duty cycles. It need not be difficult to understand the description of pulsed microwaves. One can easily conceive of microwave radiation at 1,000 MHz (million cycles per second) being pulsed at 100 Hz (cycles per second) having a peak power of 300 mW/cm<sup>2</sup> (milliwatts per square centimeter) but an average power of only 2 mW/cm<sup>2</sup>. One further concept to be encountered is that of "threshold," namely, the lowest power level at which any given effect takes place. For example, a person acclimated to cool weather may begin to feel decidedly uncomfortable when the temperature rises to 85°F, the threshold.

In a set of experiments with radiation applied to the back of human heads, three pulses 100 msec apart delivered every second were perceived as a distinct click. The threshold was well below 1 mW/cm<sup>2</sup> for pulse widths of 0.5 to 32  $\mu$ sec and peak power densities up to 10Kw/cm<sup>2</sup> (Lin, p 47). Pulse trains were described as chirps with the pitch corresponding to the pulse rate. When the apparatus was keyed manually, the test subject could accurately interpret a digital code (Lin, p 49).

Further experiments produced much data on the relative loudness that was perceived as a function of the peak power densities. It increased sharply to a maximum at 200 mW/cm<sup>2</sup> then remained nearly constant up to about 650 mW/cm<sup>2</sup> with a constant average power density of 0.32 mW/cm<sup>2</sup>. In terms of average power density, the maximum response lies in the range of 0.5 to 1.1 mW/cm<sup>2</sup> for constant peak power density of 370 mW/cm<sup>2</sup> (Lin, p 53).

The threshold for hearing 2453 MHz was found to be at an average power density of approximately 120  $\mu$ W/cm<sup>2</sup> (microwatts per square centimeter) for pulse widths from 1  $\mu$ sec to 32  $\mu$ sec with corresponding

(continued next page)

## HUMAN WHISTLE, Continued

peak power densities from 40 to 1.25 W/cm<sup>2</sup> (Lin, p 54). As the energy density per pulse remained constant at about 40 μJ/cm<sup>2</sup> (microjoule per square centimeter), the threshold occurred at that value independent of the peak power and pulse width that balanced out.

It has also been determined how the perceived loudness depends upon the pulse width. Measurements at 0.32 mW/cm<sup>2</sup> average power density showed it to be maximum from about 10 to 30 μsec, falling by a decade at 60 μsec and continuing downward rapidly (Lin, p 55).

Microphones in the auditory nerve of cats showed that the wave form produced by a pulse of microwaves was very similar to that produced by the click of a loudspeaker. The response terminated upon surgical isolation of the cochlea or sacrificial death of the test animal.

In summary, it is well established and documented that people are able to hear microwaves from 200 to 3,000 MHz with peak power densities of 100 to 300 mW/cm<sup>2</sup> and average power densities as low as 0.4 mW/cm<sup>2</sup> with pulse rates from 1 to 1000 μsec. "....the microwave-induced sound appears as an audible click, buzz, or chirp depending on such factors as pulse width and pulse repetition frequency of the impinging radiation and is usually perceived as originating within and near the back of the head" (Lin, p 51).

## ANIMAL STUDIES

Much research has been conducted on animals. In the early years, animals with avoidance training were used to establish detection thresholds. In later years, the experimental protocols became quite sophisticated. Anesthetized animals were subjected to surgical procedures for access to organs in the head and attachment of micro-electrodes for measuring electrical responses of various organs. Studies were conducted on cats to measure responses of the primary auditory cortex, brain stem, medial geniculate, eighth cranial nerve, cochlear round

window, and cochlear microphonics.

For microwaves at 2450 MHz pulsed at 20 μsec, the threshold for cats was found to be at average power density of 33.0 μW/cm<sup>2</sup> (= 0.033 mW/cm<sup>2</sup>) and energy density per pulse of 33 μJ/cm<sup>2</sup> (micro Joules per square centimeter). This data permits a direct comparison with the thresholds for man as shown in table 1.

So the peak powers are comparable but the cat is about 3.6 times as sensitive to average power as man.

In other experiments, similar data were obtained for cats and one dog at 3,000 MHz and 15-μsec pulses as pictured in table 2.

involving animal disturbances can be found in a wonderful book published by the Central European Section of The Mutual UFO Network. It is the Proceedings of their 9th Annual Conference in the format of a 471-page, quality paperback.<sup>8</sup> Of 552 cases concerning the strange behavior of every sort of mammal, insect, and fowl, 320 cases involved dogs but only 15 cases involved cats. It is well known that dogs are easily disturbed by UFOs but it is somewhat of a revelation that cats are also. Could the predominance of canine reaction be related to a preference for dogs as pets? Probably not. No one really knows the

	Peak Power (W/cm <sup>2</sup> )	Average Power (μW/cm <sup>2</sup> )	Energy Density per Pulse (μJ/cm <sup>2</sup> )	Reference
Man	2.15	120	40	(Lin, Table III, p 54)
(Ratio)	(1.3)	(3.6)	(1.2)	
Cats	1.7	33	33	(Lin, Table V, p 89)

Table 1.

Cat	0.58	8.7	(Lin, Table VI, p 81)
(Ratio)	(2.9)	(2.9)	
Dog (1)	0.20	3.0	(Lin, Table VI, p 81)

Table 2.

Thus, sufficient data is available to make a direct comparison between man, cats, and dogs, assuming that the single dog was representative of its genus. Based upon the peak power densities and energy densities per pulse, cats are comparable to man in the ability to hear microwaves with cats having 20 to 30% advantage. Dog, however, are nearly three times more sensitive than either cats or man. If UFOs emit microwave radiation of approximately the above parameters, one may be sure that dogs would detect their approach before their owners, a pattern that is well established.

## BEHAVIOR

The strange behavior of dogs under the influence of UFOs is a prominent feature in a host of sightings but the reaction of cats is less well known. A recent catalog of cases

population of dogs and cats in the United States but surveys by pet food manufacturers have produced estimates of roughly an equal number of each, somewhere near 30 million.<sup>9</sup> The differences in their responses could be attributed to their basic natures or different sensitivity to pulsed microwaves. So much for perception of pulsed microwaves as a possible explanation for the Low Pitch category of sounds associated with UFOs.

Many additional mechanisms for hearing microwaves have been proposed but most of them have been discarded by the scientific community upon discovering that their sensitivity is one or more orders of magnitude too small. The sole remaining candidate is known as the thermoplastic process. In that process absorption of a pulse of energy in biological tissue produces an extremely small increase in

(continued next page)

## HUMAN WHISTLE, Continued

temperature. Due to thermal expansion, a corresponding increase in pressure takes place that then propagates through the medium as a sound wave. A microwave pulse impinging upon the head therefore gives rise to a weak sound wave that propagates and reverberates in the cranium. Such vibrations would then be carried by bone conduction to the cochlea where, through conversion to electrical signals, they would seem audible. (Bone conduction of sound in the body is put to good use in certain types of hearing aids. An easy way to experience it is to have a friend stroke low notes on a piano with the sustaining pedal suppressed, place fingers in your ears, and rest your chin on the piano frame. It can also be fun at a local piano bar.

The thermoplastic process has been analysed by Dr. Lin in exquisite mathematic detail.<sup>10</sup> The head was theoretically represented as a sphere of brain tissue. The analysis is extremely elaborate and the computational requirements enormous. In short, it was found that the fundamental frequency reverberation that would be generated in the cranium was completely independent of the microwave parameters and dependent only upon the size (radius) of the head and the acoustical properties of brain tissue. The generated frequencies are quite high and they are inversely related to head size.

Subsequent refinement of the analysis introduced a rigid boundary to the head and extensive computer calculations indicated that the frequencies increased roughly 70% (Lin, p 157). It is expected that actual frequencies measured in the laboratory would fall between the results of the basic and improved models.

Calculated thresholds for perceiving sound through this microwave induced thermoplastic process are quite high. For input data of 2,450 MHz, 10  $\mu$ sec pulses, and 1,000 mW/cm<sup>3</sup> absorbed energy, the refined model yields a threshold of 589 mW/cm<sup>2</sup> of incident power for cats with head radius of 3 cm. (Lin, Fig. 79, p 163). The experimental result for the same

parameters was a threshold of 1,300 mW/cm<sup>2</sup> producing twice the sound pressure in the head. For man with head radius of 7 cm, the threshold was calculated to be 2,183 mW/cm<sup>2</sup> for 918 MHz, 10  $\mu$ sec pulses, and 1,000 mW/cm<sup>3</sup> of absorbed energy. These thresholds of 589 mW/cm<sup>2</sup> for cats and 2,183 mW/cm<sup>2</sup> for man are extremely high in comparison with thresholds for hearing microwave pulses that are much less than 1 mW/cm<sup>2</sup>. It is also emphasized that the thresholds far exceed the safety limits governing microwave exposures to people in the U.S. which are

a) 10 mW/cm<sup>2</sup> for 0.1 hr or longer, 10 to 100 MHz and

b) 1 mW/cm<sup>2</sup> for any 0.1 hr, 1000 MHz. (Lin, p 161.)

Anyone hearing a shrill whistle from a nearby UFO should run away as fast as possible to avoid serious injury.

Under intense irradiation, pulse rates in the auditory nerves of living but anesthetized guinea pigs and cats were measured with microelectrodes. Agreement between the theoretical predictions and experimental measurements is remarkable as shown below.

Mammal	Typical Head Radii (cm)	Theoretical Frequency Range (kHz)	Experimental Values (kHz)
Guinea Pigs	1.5 - 2.5	40 - 70	50
Cats	2.5 - 3.5	30 - 40	38
Man	7.0 - 10.0	10 - 5	Not measured

Table 3.

For both guinea pigs and cats, the experimental results fall within the range predicted by the two theoretical models of the head (Lin, p 161). The frequencies produced by the thermoplastic process are very high. The measured value for cats at 38 kHz, well within their hearing limit of 60 kHz, is beyond the human hearing limit of 20 kHz. It is not possible to say what it might sound like to cats but, on the musical scale, doubling the frequency increases the pitch by an octave. So one could guess the cat to hear something like a tone about one octave above the limit of human hearing. For medium-sized dogs with larger heads, the tone would be lower but for head radii of less than 4 cm it would still be

ultrasonic as far as humans are concerned.

## UFO MUSIC

No measurements of this effect have been made on humans nor is it ever likely because of the dangerously high incident energies. However, success of the theory for small mammals lends great confidence in interpreting the results for man. Theoretical values of 10 to 15 kHz for man represent very high-pitch tones. The highest notes produced by the piano, xylophone, glockenspiel, and piccolo do not exceed 4.19 kHz, the C four octaves for middle C.<sup>11</sup> The predicted frequencies would lie in the 6th octave above middle C or in the second octave above the piano keyboard. The musical triangle is perceived as having a very high pitch but it theoretically has no fundamental tone.<sup>12</sup> (A thrilling use of that instrument can be heard on a good hi-fi in Piano Concerto No. 1 in E Flat Major at Franz Liszt.) Old-fashioned radios used to produce a squeal between stations of 10 kHz because the broadcast frequencies of neighboring

stations were separated by 5 kHz. It was known colloquially as the 10-kilocycle whistle. This discussion should impart some idea of what the microwave, thermoplastic vibrations would sound like. The language used by UFO witnesses to describe their experiences of the High Pitch would appear to be appropos.

A rather remarkable set of facts seems to couple the known effects of microwave radiation to the auditory experiences of UFO witnesses and possibly their pets. At very low and measured thresholds, individual pulses of radiation could be heard as substitutes for sonic pressure waves

(continued next page)

## HUM'N'WHISTLE, Continued

with the transduction taking place in the cochlea. At much higher intensities, microwave pulses could initiate the thermoplastic production of high-frequency sound waves in brain tissue that depend upon head size and propagate to the cochlea via bone-conduction. It appears to be significant that pulsed microwaves can account for two major categories of sounds experienced in the presence of UFOs, especially since two distinctly different mechanisms are involved that have only been discovered recently. In other words, the technical details suggest that UFOs emit pulsed microwaves. So hum and whistle a UFO tune!

### REFERENCES

1. Vallee, Jacques, *Passport to Magonia*, Appendix, p 164 ff, Regnery, 1969.
2. McCampbell, James M., *UFOlogy*, Chapter 4, *Celestial Arts*, 1976.
3. Shaw, Frank R., and Whitehead, Stanley B., *Honey Bees and Their Management*, Van Nostrand, 1951.
4. McCampbell, *Ibid*, p 49.

5. *Digest of the 1961 International Conference on Medical Electronics*, New York, IRE.
6. Copson, David A., "Microwave Heating, In Freeze-Drying, Electronic Ovens, and Other Applications," Chapter 19, *Radiation Biology of Microwaves*, The AVI Publishing Company, 1962.
7. Lin, James, C., *Microwave Auditory Effects and Applications*, Charles C. Thomas, 1978.
8. Schneider, Adolph, *Animal Case Catalog*, March 25, 1983, *Herausgegeben von Dipl-Phys. I. Brand, Seltsame Flugobjekte Und Die Einheit Der Physik*, p 437, *MUFON-CES-Bericht Nr. 9*, 1983.
9. *Encyclopedia of Science & Technology*, McGraw-Hill, Vol 9, p 234 and Vol 5, p 801, 1977.
10. Lin, Chapter 6. The original paper was Lin, J.C., "Microwave-induced Hearing: Some Preliminary Theoretical Observations," *J. Microwave Power*, 11:295-298, 1976.
11. McGraw-Hill, *Ibid*, p 772.
12. *Encyclopaedia Britannica, Micropaedia, Ready Reference and Index, Vol. X*, p 114.

© 1985 James McCampbell

# MUFON

103 OLDTOWNE RD.  
SEGUIN, TX 78155

### UFO NEWSCLIPPING SERVICE

The UFO NEWSCLIPPING SERVICE will keep you informed of all the latest United States and World-Wide UFO activity, as it happens! Our service was started in 1969, at which time we contracted with a reputable international newspaper-clipping bureau to obtain for us, those hard to find UFO reports (i.e., little known photographic cases, close encounter and landing reports, occupant cases) and all other UFO reports, many of which are carried only in small town or foreign newspapers.

"Our UFO Newsclipping Service issues are 20-page monthly reports, reproduced by photo-offset, containing the latest United States and Canadian UFO newsclippings, with our foreign section carrying the latest British, Australian, New Zealand and other foreign press reports. Also included is a 3-5 page section of "Fortean" clippings (i.e. Bigfoot and other "monster" reports). Let us keep you informed of the latest happenings in the UFO and Fortean fields."

For subscription information and sample pages from our service, write today to:

UFO NEWSCLIPPING SERVICE  
Route 1 — Box 220  
Plumerville, Arkansas 72127

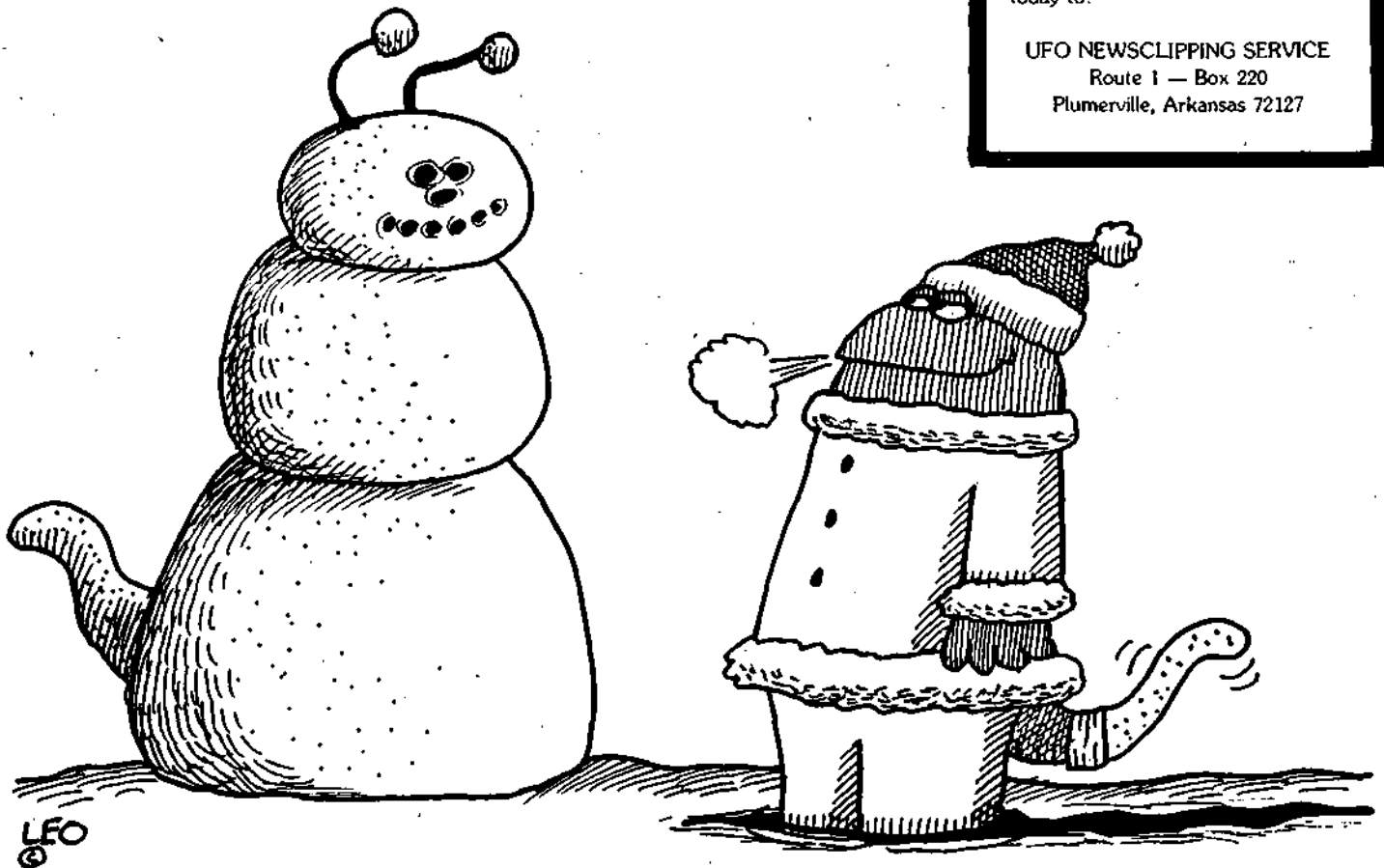

## DIRECTOR'S MESSAGE, Cont.

Francisco, California, aired a full hour UFO program from 7 to 8 p.m. on November 24, 1984, through the cooperation of **Paul Cerny, Tom Gates** and other members in the San Francisco Bay Area group.

\*\*\*

The TELUFONET was utilized to advise all State Directors on the showing dates and times of CNN's UFO documentary, with the initial call by **Marge Christensen** to **Thomas P. Deuley** and **Douglas Labat** at 10:40 a.m. C.S.T. on Saturday, January 19th. A revised TELUFONET list was mailed on 1/21/85 to State Directors affected. If any State Director has misplaced their TELUFONET list or needs the revision, please contact **Walt Andrus**. The MUFON P.I.P.E. Line newsletter is mailed only to the people on the national committee, not to all State Public Relations Directors as stated in my Director's Message in the January 1985 issue of the Journal.

\*\*\*

With the airing of "UFOs: The Bentwaters Incident," the demand for the new book **SKY CRASH: A Cosmic Conspiracy** by **Brenda Butler, Jenny Randles** and **Dot Street**, has exceeded existing supplies. There are at least two sources in the U.S.A. which would be more convenient than ordering from the publisher in England to obtain your personal copy. **Arcturus Book Service**, 263 North Ballston Ave., Scotia, NY 12302 U.S.A., has listed **SKY CRASH** for \$13.95 plus 85¢ for fourth class postage in their January 1985 catalog. **Bob Girard** has advised that this first order was sold out immediately and the waiting list will be filled with his second shipment. He will gladly accept your order, but it will be treated as a reservation for future shipments (telephone 518-372-2373). At the time of this writing, **William L. Moore Publications**, 4219 West Olive St., Suite 247, Burbank, CA 91505 (telephone 818-506-8365), still had a small supply at \$14.00 postpaid.

\*\*\*

The newsletter **JUST CAUSE** published by **Lawrence Fawcett**, and edited by **Barry Greenwood**, has resumed publication with thier second

issue, dated December 1984. Consisting of four pages, a subscription may be obtained from P.O. Box 218, Coventry, CT, 06238, for the price of 4 issues - \$10 (\$15 foreign).

\*\*\*

**Kenneth W. Behrendt**, 274 Second St., Elizabeth, NJ 07206, who has formerly published articles in *The Sixth Quark Journal*, *The SBI Report* and the *Cambridge UFO Research Group Newsletter*, has now become the editor and publisher of his own twelve-page UFO semi-technical magazine titled *Annals of Ufological Research Advances* (AURA) with volumen 1, no. 1 dated January 1985. He does not advise the subscription price or frequency of issue, therefore we refer interested readers to the above address.

\*\*\*

**Dr. Virgilio Sanchez-Ocejo**, MUFON Special Representative to South America and President of the Miami U.F.O. Center, P.O. Box 313, Opa Locka, FL, 33054, has set up a window display in a book store in the heart of "Little Havana" in Miami, Florida. The sign on the window in Spanish reads **INFORMESE CUANTO ANTES** or translated: "get information as soon as possible." Every Saturday their members are present to provide information about the UFO phenomenon and various organizations, publications and books for the public.



Barry Greenwood

## In Others' Words

UFO reports from China, as detailed by author **Paul Dong**, are featured in the November 6 **NATIONAL ENQUIRER** issue. Dong's book, **THE FOUR MAJOR MYSTERIES OF MAINLAND CHINA**, contains a section on UFOs which describes numerous UFO sightings from all parts of that country. In Brazil, the small town of **Demerval Lobao** has been "terrorized" by egg-shaped UFOs during 1984, according to an article in the **ENQUIRER's** November 13 issue. UFO sightings near **Tyrone, Pennsylvania** are the subject of a report in the December 11 issue.

**Doug Curran** doesn't particularly believe in "flying saucers," but his travels all over North America in the past six years have been in search of people who do believe. Curran, a Canadian photographer, will publish his observations and photographs in a book titled **IN ADVANCE OF THE LANDING: FOLK CONCEPTS OF OUTER SPACE**. A summary of his research appears in the "Anti-Matter/UFO Update" section in the December issue of **OMNI**.

**Bruce Maccabee's** continuing series of articles for **FATE** focuses on cases from 1949 (New Mexico) and 1950 (Alaska), in the January issue of that magazine. The February issue contains an article by Maccabee on missing Air Force films of UFOs which were taken during 1950 sightings in New Mexico.

Although it does not pertain directly to UFO research, **JOURNAL** contributor **Ann Druffel** has co-authored a book with **Armand Marcotte**, **THE PSYCHIC AND THE DETECTIVE**, dealing with Marcotte's psychic investigations of crimes. For those who may wish to obtain a copy, the book is available at \$7.95 (softcover) from **ACS Publications** - P.O. Box 16430 - San Diego, CA 92116.

A new line of paperbacks, featuring material from the **NATIONAL ENQUIRER**, will be published as a joint venture with **Pocket Books**. One of the first titles in the series will be **UFO REPORT**, available in May.

-Lucius Farish

# DIRECTOR'S MESSAGE

by  
Walt Andrus

The UFO Study Group of Greater St. Louis, host for the MUFON 1985 UFO Symposium at the Chase Hotel in St. Louis on June 28, 29, and 30, 1985, has announced the following specific plans for this year's event: 1) The featured speakers are George Fawcett, Stanton Friedman, Peter Gersten, Budd Hopkins, William Moore, Ted Phillips, John Schuessler, Leonard Stringfield and David Webb; 2) Advanced reservations for all four sessions is \$25.00 prior to June 21, 1985; 3) Checks should be made payable to "UFO Study Group of Greater St. Louis" and mailed to Mrs. **Helen C. Henke**, 4024 90th Ave., Florissant, MO 63034; 4) The price at the door for all sessions will be \$28.00; 5) The price for each of the four sessions is \$7.50; 6) An added feature of this year's symposium will be a "Breakfast With the Speakers" on Sunday morning.

This will be an opportunity for everyone to talk with the speakers and be served a full course, delicious breakfast by the Chase Hotel. The price of the breakfast will be \$10.00 and reservations are open until June 24, 1985. Hotel reservations can be made by contacting the Reservation Manager, Chase Hotel, 212 North Kingshighway, St. Louis, MO 63108. The phone number is (314) 361-2500. Fifty rooms are being held for attendees, but reservations should be made no later than thirty (30) days prior to the Symposium to insure accommodations. Room rates are \$60.00 per day for a single or double, \$70.00 for three persons and \$80.00 for four persons. There is no charge for children under 18 years of age.

\*\*\*

With the recent introduction of new ultra-saver rates by the major airlines to match the rates of other carriers, substantial savings may be obtained by making your reservations to St. Louis now in order to meet the



specific conditions applicable to these new rates.

**Donald M. Ware**, State Director for Florida, has selected **Everett R. Walter, Ph.D.**, as his Assistant State Director. Dr. Walter is also a Consultant in Electrical Engineering for MUFON. His prime responsibility will be to seek competent people in southern Florida. Two promotions were recently announced by **Bruce A. Widaman**, State Director for Missouri. **Walter A. Palmer** is the Assistant State Section Director for St. Louis County, and **Joseph L. Palermo** has accepted the responsibility as Director of Public Information for Missouri. **Thomas M. Clark** of Mt. View, California, has volunteered his expertise as a Research Specialist in Propulsion Systems.

\*\*\*

It is a pleasure to welcome back **Robert D. Boyd** to his former position as State Section Director for Mobile and Baldwin Counties in Alabama, after having lived in England for over six years. Bob took advantage of this time to prepare a 345-page report titled "A Comparative Unit." The content of this work consists of over one hundred

cases initially reported as UFO sightings and/or experiences over Mobile and Baldwin counties, Alabama, U.S.A. These sightings occurred from 1947 through 1977, within a geographical area of approximately 4,000 square miles. This area, including bodies of water, is located between coordinates 30.10 to 31.15 Latitude north and 87.25 degrees Longitude, west.

\*\*\*

Typical examples of recent UFO electronic media public education programs across the country consist of the following outstanding events:

1) Cable News Network (CNN) produced the special assignment documentary "UFOs the Bentwaters Incident" by Chuck DeCaro, in cooperation with **Larry W. Fawcett** (showing dates January 22 through 25).

2) WLS-TV Channel 7, Chicago, produced a live one-hour segment on UFOs on January 18, 1985 (9 to 10 a.m.), on the very popular program "AM Chicago," hosted by Miss Oprah Winfrey. Walt Andrus and two of the abductees from Budd Hopkins' paper "The Haunting of Kitley Woods" from Indianapolis, Indiana, appeared (on January 29th, Oprah Winfrey appeared on the Johnny Carson Show with Joan Rivers as host, based upon her own popularity as a TV talk show personality).

**Ray Boeche** and **Scott Colburn** are the hosts for a weekly program on KZUM/FM in Lincoln, Nebraska, each Saturday morning from 11 a.m. to noon, titled "Unexplained Phenomena."

4) KVUE-TV Channel 24 in Austin, Texas, ran a segment featuring **Walt Andrus** and the work of the Mutual UFO Network on January 29, 1985, on the program "Good Morning Austin."

5) KGO-TV Channel 7 San

(continued on page 19)

# MUFON UFO JOURNAL

NUMBER 203

MARCH 1985

Founded 1967

OFFICIAL PUBLICATION OF



MUTUAL UFO NETWORK, INC.

\$1.50

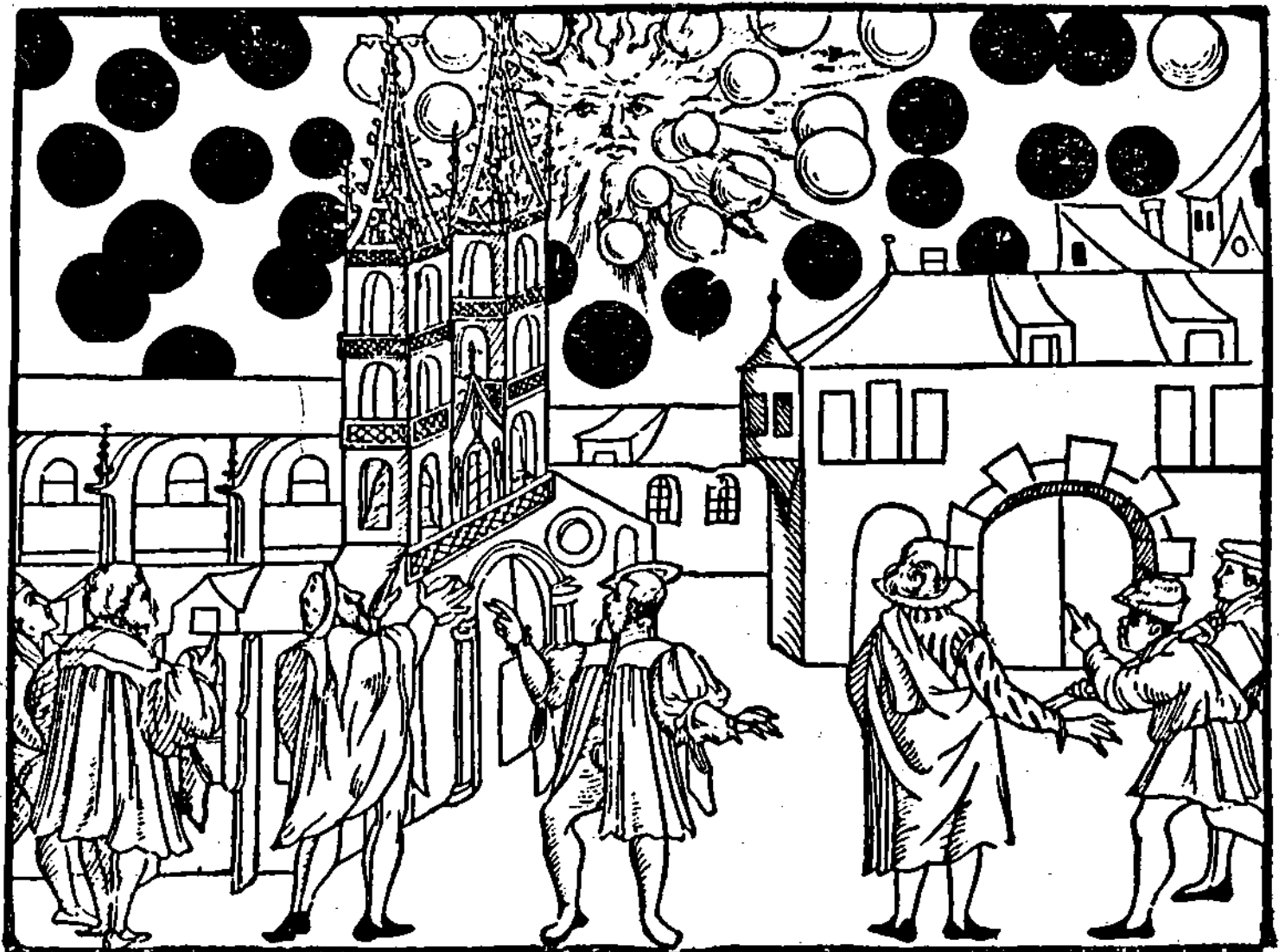

Basel, Switzerland, 1566

**MUFON UFO JOURNAL**  
 (USPS 002-970)  
 (ISSN 0270-6822)  
 103 Oldtowne Rd.  
 Seguin, Texas 78155-4099

**DENNIS W. STACY**  
 Editor

**WALTER H. ANDRUS, JR.**  
 International Director and  
 Associate Editor

**THOMAS P. DEULEY**  
 Art Director

**MILDRED BIESELE**  
 Contributing Editor

**ANN DRUFFEL**  
 Contributing Editor

**TED BLOECHER**  
**DAVE WEBB**  
 Co-Chairmen,  
 Humanoid Study Group

**PAUL CERNY**  
 Promotion/Publicity

**MARGE CHRISTENSEN**  
 Public Relations

**REV. BARRY DOWNING**  
 Religion and UFOs

**LUCIUS FARISH**  
 Books/Periodicals/History

**ROSETTA HOLMES**  
 Promotion/Publicity

**GREG LONG**  
 Staff Writer

**SIMONE MENDEZ**  
 Staff Artist

**TED PHILLIPS**  
 Landing Trace Cases

**JOHN F. SCHUESSLER**  
 Medical Cases

**LEONARD STRINGFIELD**  
 UFO Crash/Retrieval

**WALTER N. WEBB**  
 Astronomy

**NORMA E. SHORT**  
**DWIGHT CONNELLY**

**DENNIS HAUCK**

**RICHARD H. HALL**

**ROBERT V. PRATT**

Editor/Publishers Emeritus

The MUFON UFO JOURNAL is published by the Mutual UFO Network, Inc., Seguin, Texas. Membership/Subscription rates: \$15.00 per year in the U.S.A.; \$16.00 foreign in U.S. funds. Copyright 1985 by the Mutual UFO Network. Second class postage paid at Seguin, Texas. POSTMASTER: Send form 3579 to advise change of address to The MUFON UFO JOURNAL, 103 Oldtowne Rd., Seguin, Texas 78155.

# FROM THE EDITOR

In our centerspread this issue you'll find the prevailing critical British viewpoint toward the Rendlesham Forest Affair as represented by skeptic Ian Ridpath. Next month you'll be able to read Jenny Randles' lengthy commentary on what has transpired in the Affair since the publication of SKY CRASH!

The issue will be a special International Edition with a variety of articles that indicate the world-wide scope of the UFO phenomenon. In the meantime, we'd like to thank our Art Director, Tom "Macintosh" Deuley for the computer generated graphics which appear on page 3 and 17, with more to come; Leonard Bruce for his timely cartoon; and Janet & Colin Bord of the Fortean Picture Library for our cover: "From a Basel broadsheet written 1566 by Samuel Coccius, describing how on 7 August 'many large black globes were seen in the air, moving before the sun with great speed, and turning against each other as if fighting. Some of them became red and fiery and afterwards faded and went out.'"

## In this issue

SAY HELLO TO E-T! by Donald M. Ware .....	3
UFOS: MORE ENGINE EFFECTS by James McCampbell .....	4
FARISH'S ROLE IN RENDLESHAM by Walt Andrus .....	7
SIGHTINGS by Mark Uriarte & Brad Sparks .....	8
A FLASHLIGHT IN THE FOREST by Ian Ridpath .....	10
CARTOON by Leonard Bruce .....	13
NEWS'N'NOTES .....	14
LETTERS .....	16
APRIL STARS & PLANETS by Walter Webb .....	18
DIRECTOR'S MESSAGE by Walt Andrus .....	20

The Mutual UFO Network, Inc. is exempt from Federal Income Tax under Section 501(c)(3) of the Internal Revenue Code. MUFON is a publicly supported organization of the type described in Section 509(a)(2). Donors may deduct contributions from their Federal income tax. In addition, bequests, legacies, devises, transfers, or gifts are deductible for Federal estate and gift tax purposes if they meet the applicable provisions of Sections 2055, 2106, and 2522 of the code.

The contents of the MUFON UFO JOURNAL are determined by the editor, and do not necessarily represent the official position of MUFON. Opinions of contributors are their own, and do not necessarily reflect those of the editor, the staff, or MUFON. Articles may be forwarded directly to MUFON. Responses to published articles may be in a Letter to the Editor (up to about 400 words) or in a short article (up to about 2,000 words). Thereafter, the "50% rule" is applied: the article author may reply but will be allowed half the wordage used in the response; the responder may answer the author but will be allowed half the wordage used in the author's reply, etc. All submissions are subject to editing for style, clarity, and conciseness.

Permission is hereby granted to quote from this issue provided not more than 200 words are quoted from any one article, the author of the article is given credit, and the statement "Copyright 1985 by the Mutual UFO Network, 103 Oldtowne Rd., Seguin, Texas" is included.

# SAY HELLO TO E-T!

Donald M. Ware  
State Section Director, Florida

For the purpose of this exercise let us assume that some UFO's are extraterrestrial craft controlled by beings of advanced intelligence. The common knowledge of these beings would probably include what we humans consider advanced technology. A problem that now emerges is how to convert common knowledge of aliens to useful information for humans. The potential benefit of progress on this problem makes it worth consideration by serious investigators.

If we view the total information associated with the UFO phenomenon as a pie, that portion of this information acquired by government agencies and by civilian investigators can be represented by slices of the pie as shown below.

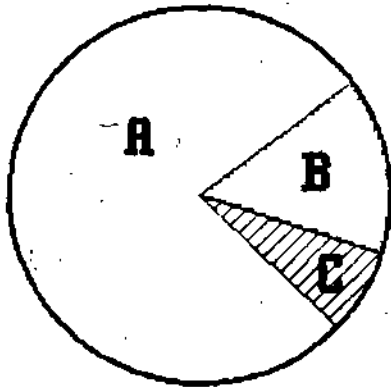

- A. Information associated with UFO phenomenon.
- B. Information acquired by government agencies.
- C. Information published by civilian investigators.

The relative size of the B slice, previously acquired information, cannot be determined. The total amount of information available is not known, and the information acquired by some government agencies remains classified. What does seem apparent is that the amount of information published by civilian investigators is a

small portion of that acquired by government agencies. This is based on acceptance of the evidence indicating retrieval of crashed vehicles, i.e., *The Roswell Incident* and Leo Stringfield's status reports; government possession of data from numerous encounters with camera and radar; and alien communication with military commanders during landings at Holloman AFB, NM in 1968, and possibly near Bentwaters AFB, United Kingdom in 1980.

## ALIEN COMMUNICATION

There is also evidence in the UFO literature of civilians communicating with aliens. Several such cases that have been investigated by trained UFO investigators are: Betty Andreasson in *The Andreasson Affair* by Ray Fowler; Virginia Horton and others in *Missing Time* by Bud Hopkins; and the mother in the "Mother and Child Texas Abudction Case," *MUFON UFO Journal*, Jan. 1982. During most of the 100 or more apparent abductions that have been investigated, an opportunity was available for the abductee to ask questions. In some, the opportunity was specifically offered. It is interesting to note that Betty Andreasson, and several individuals investigated by Bud Hopkins, apparently had more than one encounter with alien beings. Can we assume that some other abductee will have another encounter? And, if one did, will we humans be able to take advantage of the situation and learn something significant?

It seems apparent that aliens have not voluntarily imparted significant technical knowledge to the human race. Perhaps it is their policy not to do so to avoid too great an impact on our society, or for some reason. If this is true, then any technical information we might acquire could be considered unofficial, but still useful and interesting.

## FUTURE QUESTIONS

Now let us consider several questions that might be asked by future abductees, the answers to which, although "unofficial" might produce significant information. It is important that the questions be balanced between being too technical to teach to past abductees and perhaps the general public, and being too non-technical to produce useful information.

1. *How can we best contain a thermonuclear reaction?* Our scientists have been working hard on this problem for many years in the laboratories of Princeton, Los Alamos and Lawrence Livermore. The quest for safer and cheaper energy has tremendous potential benefits for all humans. Any useful information from aliens in this area could probably be recognized within a few years, and the results could not be hidden under the lid of government secrecy for long because of the need for cheaper energy in the open market.

2. *Describe yourself biologically; i.e., body temperature, pulse rate, respiration rate, food and oxygen requirements, etc.?* Answers to this question could help relieve our fear of the unknown and allow humans to develop friendlier thoughts toward alien visitors. If any great surprises occur, that would be interesting too. Much of this information is not readily obtainable from cadavers that may be in the possession of some government agency.

3. *How far away is your home planet, and how long, in earth time, did it take you to get there?* A simple answer to the first part would hopefully be in light years. An answer to the second part would indicate the average speed of travel.

4. *How long have your people been watching us, and what are your*

(continued on page 6)

# UFOS: MORE ENGINE EFFECTS

by  
*James McCampbell*

## DIESELS, TOO?

UFO interference with automotive engines is well recognized and thoroughly documented. Catalogs of such events have been compiled in Australia, England, Germany, and the United States. In 1981, the Center for UFO Studies released summaries and statistical analyses of 441 cases including 268 in which engines not only ran roughly and lost power but completely stalled.<sup>1</sup> Only one case in that catalog pertained to the failure of a diesel engine that coincided with loss of headlights along with many other details that will be reviewed later.<sup>2</sup>

Although not intended to be comprehensive, a rather extensive search of the literature for the present study uncovered only four additional cases that occurred after the CUFOS publication or whose original documentation may have been unavailable. A review of eight known events may shed some light upon this perplexing and apparently neglected subject.

A very famous case in Forli, Italy on November 14, 1954, (Case 1). Two tractors were being driven side-by-side down a road when a UFO was encountered. One of them, operating on gasoline with electrical ignition, failed but the other one, a diesel-powered machine, did not.<sup>3</sup>

## ELECTRICAL INTERFERENCE

As many hundreds of UFO sightings have involved electrical interferences of wide variety, it was natural and probably correct for most people to attribute the failure of gasoline engines to some sort of electromagnetic phenomenon. However, that conclusion may have spawned a subtle and pervasive notion that diesels are immune to interference by UFOs.

Another highly publicized example

that demonstrates the resistance of diesels took place in the early morning hours of November 6, 1967, in England (Case 2). While driving a diesel truck, the witness saw a strange, egg-shaped object above some trees about ¼ mile away. The lights and radio went out but the engine continued to run as the object landed on the road only 15 yards away. A flexible tube came from the bottom of the UFO with a box on the end. Connected to the box were four short hoses that sucked up grass, gravel, and dead leaves from both shoulders of the road. Then a Jaguar that drove up to the landed UFO on the opposite side lost both its headlights and engine.<sup>4</sup> So again under comparable circumstances, a diesel engine continued to run while a presumably, spark-ignited engine failed.

That diesel engines can be disrupted was probably first observed on a fishing boat plying Hawk Inlet, Alaska on December 16, 1958 (Case 3). The UFO had been seen the previous day floating on the water about ¼ mile away. When it appeared about 70 ft. above the mast, the fisherman radioed the Coast Guard. About 5 minutes later, the "boat's power" failed and the radio went dead. An auxiliary diesel generator was barely running but it came back to normal as the UFO flew away.<sup>5</sup>

The description of this case is less than explicit but the language would ordinarily be taken to mean that the boat's propulsion system failed. It would be rare, indeed, for a boat with a diesel generator to be powered by other than a diesel engine thereby requiring the storage of two different kinds of fuel. Nevertheless, it is quite clear that the diesel generator malfunctioned, a detail that will be seen in other cases.

Robert Gomez was driving a "vacuum" truck west of Alice, Texas in the early afternoon of June 12, 1981 when he encountered a hovering, disc-

shaped, and brightly-glowing object (Case 4). As his truck slowed down, he depressed the the accelerator to maintain speed and reported that the exhaust stacks were blowing smoke. The truck seemed to be about 1 ft. above the road. His AM radio failed but he was able to report to his dispatcher on a CB. The AM came back on when the UFO disappeared into some clouds.<sup>6</sup>

Gomez was carrying 165 gallons of water under no pressure at the time of the sighting but the tank was later found to be pressurized to 55 psi. Upon attempting to drain the tank, no water came out. Only steam. From thermodynamic relations it can be established that the temperature of the water and vapor in the tank had been increased to about 303°F. Upon opening the drain, he reduced the pressure at the exit to 14.7 psi, one atmosphere. As the vapor pressure of the hot water was 69.7 psi absolute, it would suddenly flash to steam and that process would continue until the tank was empty. Further information in this case is being sought so that a detailed, quantitative analysis can be done.

On March 21, 1974, 21-year-old Maximiliano Iglesias Sanchez had two remarkable and complex encounters with several UFOs and their occupants (Case 5). While driving a diesel truck at 2:30 a.m., he approached to within 200 meters of a UFO standing on the highway and spanning the breadth of the pavement. His lights and engine failed. Another UFO was seen nearby and two, tall human-like creatures. At 11:15 p.m. the same day, he saw three UFOs at the same location with one sitting on the road. Again, the engine failed. He panicked as four "beings" approached him and then hid in a ditch 2 kilometers away to escape their pursuit. Later, upon driving away and yielding to curiosity, he returned to the

(continued next page)

## DIESELS, TOO, Continued

site on foot and observed four beings working on an embankment with strange tools.<sup>7</sup>

### TRAIN STALLS

A diesel train of 14 cars was stalled on March 10, 1983, by a huge UFO near Ventilla, Bolivia, (Case 6). First seen as an enormous, blinding cloud of light over the city, it then flew toward the train changing color from bright white to glowing orange. Seventy passengers on board were awakened and screamed in terror. A yellow ray of light struck the locomotive and stalled the engine. Engineer Sixto Churaz said that "I tried to start up the engine, but it was dead. Fifteen minutes later the engine suddenly came to life again as the object began to move away from the train." The locomotive had just been through an overhaul and was found to be in perfect condition. Experts from the University of Oruro, railroad officials, and local police confirmed that a UFO had paralyzed the train and that it was not a mechanical breakdown. On three previous nights, nearby villagers being harassed by UFOs tried to frighten them off with gunfire.<sup>8</sup> This episode introduces the extremely challenging element of the engine starting by itself as the UFO departed, a circumstance that has been reported on 27 other occasions for spark-ignited engines.<sup>9</sup>

A truly impressive event took place in Nha Trang, Vietnam at 9:45 p.m. on June 19, 1966 (Case 7). A brightly glowing UFO was seen flying at an estimated altitude of 25,000 ft. over a large, U.S. military base. It dropped down to hover at 300 to 500 ft. above an outdoor movie, appearing to be about 50 ft. in diameter and illuminating the whole area as bright as day. The diesel generator for the movie projector was knocked out. Just outside the base, 8 huge bulldozers (D9s) were working in the dark on missile sites. All their lights went out and their engines failed. At an airfield about 1/2 mile away, six independently-operating, diesel generators failed. Also, two Skyraider fighter planes were revving engines on the runway that failed. They were single-seat, combat aircraft with

powerful, reciprocating, radial engines that burned aviation gasoline. Finally, a Shell Oil Company tanker that was anchored offshore experienced a complete blackout.<sup>10</sup>

Eight UFOs were sighted between November 9 and December 14, 1978, in the vicinity of an oil-gathering center near Kuwait City, Kuwait (Case 8). The government appointed a committee of experts from the Kuwait Institute For Scientific Research to investigate. An Institute representative, Ratib Abu Id, told U.S. embassy officials that they had rejected the idea of espionage devices and did not know enough about the subject to rule out spaceships. In addition to the events above, a senior official of the Kuwait Oil Company (KOC) reported to the embassy that the UFO "...which first appeared over the northern oil fields seemingly did strange things to KOC's automatic pumping equipment. This equipment is designed to shut itself down when there is some failure which may seriously damage the petroleum gathering and transmission system and it can only be restarted manually. At the time of the UFO's appearance the pumping station automatically shut itself down and when the UFO vanished the system started itself up again."<sup>11</sup>

It would be helpful to learn exactly what kind of engine failed and self-started. So a letter of enquiry and a package of information were sent to Mr. Id via the State Department and the Kuwait Embassy. After a two month delay and a follow-up letter, no response has been received. Similarly, the Kuwait Oil Company remains silent regarding details about the event and the subject engine.

Isolated instances of strange effects from UFOs can be easily set aside. The information is not consciously rejected but its acceptance as fact would force an uncomfortable effort to fit it somewhere into one's mental construct or perception of the UFO phenomenon. So it is with diesel interference. Only when sufficient evidence is assembled does it become compelling to try to understand what is happening.

The above cases suggest that diesels are, indeed, subject to disruption by UFOs. They include the

various patterns so typical of spark-ignited engines, namely, a) a rough running and power loss, b) stalling, c) failure to restart, and d) self-starting. Cases involving both types of engines indicate that diesels are more resistant than spark-ignited engines and that a different mechanism is responsible.

Four basic factors are required by an operating engine, namely,

- 1) mechanical structure and parts (timing),
- 2) suitable fuel,
- 3) oxygen, and
- 4) ignition (spark or compression).

All previous efforts to analyse interference with automotive engines have been focused upon the electrical, ignition system. But failure of ordinary diesel engines cannot be attributed to a system that is not present. Rarely, if ever, is mechanical damage reported that would necessarily persist after a UFO event. Neither does it appear that changes take place in the fuel supply making it unsuitable. One is left with a strong suspicion that diesel interference must somehow be related to the oxygen supply. While that notion may appear to be unreasonable, there is scientific justification to examine the possibility, a task beyond the scope of this paper.

Self-starting of the Kuwait pumping station is a real puzzler! The analysis of 27 known cases of spark-ignited engines that started by themselves showed that they all occurred as the UFO flew away.<sup>12</sup> That pattern was faithfully repeated in Kuwait. But the only proposed mechanism for self-starting is based upon a sustained arc discharge across the breaker points while the UFO is present. It's collapse upon departure of the UFO would ignite a cylinder with a fresh charge that had come to rest past top-dead-center. Engine cranking would be vigorous. But large, fixed engines are usually diesels and there is the rub.

## DIESELS

The notably higher efficiency of diesel engines over gasoline engines is achieved by using a higher compression

(continued on next page)

## DIESELS, TOO, Continued

ration. The compression ratio in gasoline engines is limited to about 7 or 8 to 1 to avoid explosive pre-ignition of the fuel-air mixture. Ratios of 14 to 1, however, are possible with diesels because they compress only air. A metered amount of fuel under high pressure is sprayed into the cylinder at the critical time. With the air temperature in the cylinder at about 500°F, the fuel is immediately ignited so spark plugs are not required.

When reliable supplies of natural gas are available, such as in petroleum fields and along gas pipelines, it can be used as a fuel in stationary engines. Older types of these engines compressed a mixture of gas and air but were limited to low compression ratios typical of gasoline engines. This problem was circumvented by designs that utilized very lean mixtures of gas and air, yielding compression ratios that were comparable to diesels. Ignition in them was produced by a pilot injection of fuel oil supplying only about 5% of the BTUs. Even that small amount of refined oil can represent a significant logistics problem and expense, so in later developments, manufacturers introduced models that replaced the diesel oil injectors with spark plugs! These engines, known as "high-compression, spark-ignited gas engines" are produced in great variety by several manufacturers in the range of about 1500 to 4500 horsepower. They are "...the ideal choice for compression stations on gas pipelines."<sup>13</sup>

Because of the higher pressure of gases in the spark gap, these engines require much more powerful electrical systems in accordance with Paschen's Law. Secondary circuits operate at about 25,000 volts. So they would be uniquely sensitive to interference by any source of ionization in the atmosphere that would reduce the breakdown potential and permit shorting the high-voltage surges to ground rather than allowing delivery to the spark plugs. While there are many variations in design of the electrical systems, they have breaker points.<sup>14</sup>

Consequently, collapse of an arc across the points could cause this type

of diesel to self-start in complete analogy to automobile engines. It is hoped that complete descriptions may eventually become available for both the engine in the Bolivian train (Case 6) and the one in the Kuwait pumping station (Case 8).

### REFERENCES

1. Rodeghier, Mark, *UFO Reports Involving Vehicle Interference, A Catalogue and Analysis*, edited by Mimi Hynek and Sanna Hans Longden, Center for UFO Studies, October, 1981.
2. Rodeghier, *ibid.*, pp 61 and 78.
3. Lorenzen, Coral and Jim, *UFOs, The Whole Story*, p 145, Signet, 1945.
4. Lorenzen, Coral and Jim, *Encounters With UFO Occupants*, p 16, Berkley, 1976.
5. Summary in Falla, Geoffrey, "Vehicle Interference Project," p 49, *The British UFO Research Association*, publication date unknown but later than July 1978. Original source was APRO Bulletin, May/June, p 6, 1969.
6. Hill, James M., "South Texas Vehicle Effect Cases," *MUFON UFO Journal*, p 8, January 1982.
7. Olmos, Vicente-Juan Ballester, *A Catalogue of 200 Type-I UFO Events in Spain and Portugal*, p 44, Center for UFO Studies, 1976. First hand investigation by Olmos. Detailed accounts and translations from Stendek are available in *Skylook*, Vol 83 p 5, October 1974, Vol 85, p 3-7, December 1974, and Vol 88, p 5, March 1975, *Mutual UFO Network*.
8. Richman, Gary, *Stunned Passengers Watch In Terror As UFO Stops Train Cold*, *National Enquirer*, July 26, 1983. Kindly supplied by Lucius Farish.
9. McCampbell, James M., *UFO Interference With Vehicles And Self-Starting Engines*, in *UFOS: A Scientific Challenge*, MUFON 1983 UFO Symposium Proceedings, p 46, Pasadena, California, July 1, 2, & 3, 1983.
10. Fowler, Raymond E., *UFOS: Interplanetary Visitors*, p 102, Exposition Press, 1974. Also Stringfield, Leonard H., *Situation Red, The UFO Siegel*, p 197, Doubleday, 1977.
11. Cable No. 79 Kuwait 486, January 29, 1979 and Cable No. 80 Kuwait 3223, July 8, 1980 from the American embassy in Kuwait to the Secretary of State in Washington. The cables, the latter having been previously classified Confidential, were released under the Freedom of Information Act to Peter Gersten et al who kindly furnished copies to the author. This case was briefly mentioned by Gersten in "What The Government Would Know About UFOs If They Read Their Own Documents," in *UFOS...the Hidden Evidence*, 1981 MUFON UFO Symposium Proceedings, p 26, M.I.T., Cambridge, Mass., July 25 & 26, 1981. It is extremely interesting to note in the cables how widely UFO information is dispersed throughout the government. Copies were sent to the American embassies in Abu Dhabi, Dora (Iraq), London, Al Manamah (Bahrain) and Muscat. The U.S. Commander in Chief (Europe) duly received his copy. Distribution in Washington included the Secretary of Defense, National

Aeronautics and Space Administration, National Security Council, National Science Foundation, Department of Energy, Central Intelligence Agency and about a dozen other agencies that cannot be positively identified.

12. McCampbell, *op. cit.*, 1983.

13. Kates, Edgar J., *Diesel and High Compression Gas Engine: Fundamentals*, Chapter 18, *High-Compression Gas-Burning Engines*, American Technical Society, 2d Edition, 7th Printing, 1965.

14. Kates, *ibid.*, p 404.

©1985 James McCampbell

## SAY HELLO, Continued

reasons for being here now? The first answer could add some credibility to the work of ufologists who have studied the Book of Dyzan, the Bible, and other indications of Ancient Astronauts. The second part of the question is more complex, since there are probably numerous answers. It is far more complicated than asking our sociologists why they study the primitive tribes of Brazil or the Philippines, etc. The answers, if well publicized, could foster a less hostile attitude toward the aliens.

5. How do you eliminate fear in humans? Abduction stories in the literature include numerous accounts of aliens causing humans to go rapidly from a state of panic to one of calm and peacefulness. This is presumably done to relieve hysteria caused by fear. Mastering this capability would certainly have national defense implications. Information on how to do this could lead to research by medical and physical scientists.

6. How do you control gravity? This question is more presumptive than the others, and the answer may be too technical to be made unofficially to an abductee who is not a physicist. However, even admission that they do control gravity would be interesting; so if an abductee runs out of other questions he might try this one.

MUFON field investigators who have contact with past abductees may find it productive to provide them with a list of questions they might ask an alien if they ever get the chance.

There also seems to be no harm in

(continued on next page)

# FARISH'S ROLL IN RENDLESHAM

by Walt Andrus

Quoting from *SKY CRASH*, page 29, the following two paragraphs describe Mr. Farish's contribution by the authors to this mystery:

"The other relevant information that Bob Easton had to offer had come from Norman Oliver, then editor of the *BUFORA* Journal. Norman had actually received a letter from one of his contacts in the U.S.A., ufologist Lucius Farish. Lucius had been approached in the last couple of weeks by a U.S. Air Force man who had been sent back to America from his tour of duty in Britain, and discharged from the service. Medical reasons were cited, but he insisted that it was because he had refused to keep silent about 'something big' that had taken place on the base where he was stationed in England, during late December and early January.

"It was not clear whether this mysterious witness, whom we have never been able to trace, was relating things that he had seen or simply fanning the rumors that were spreading around the base. But it seems that he was claiming that there was not merely one landing, but several! These all happened over the course of a few weeks. To a point this confirmed what Steve Roberts had said. The close encounter he was party to was not the only one that had happened."

Since new eyewitnesses have been revealed in the United States after the book was released on October 24, 1984, Walt Andrus wrote to Lucius Farish to obtain clarification of his contribution to the Bentwaters Case as related above by Jenny Randles in *SKY CRASH*. Because few essential details and facts were available from this mysterious witness, and the information was at least fourth hand, that is 1) mysterious witness, 2) Lucius Farish, 3) Norman Oliver, and 4) Bob Easton, Walt Andrus was anxious to get to the bottom of this lead.

Quoting from Lucius Farish in his

letter of January 14, 1985, in response to my inquiry, he has volunteered the following clarification: "I can understand your interest in my 'role' in the Rendlesham Case, as related in the book. Unfortunately, virtually none of the information pertaining to me is correct!" Lou explains that "I received a note from one of the UFON (UFO Newsclipping Service) subscribers, enclosing a portion of a letter which a friend or relative of his had received. The letter-writer was (as memory serves) the wife of someone stationed at the Air Force Base. She briefly mentioned the rumors then making the rounds of the base (landing of a UFO, possible occupants, etc.). As this was the first I had heard of the incident, I wrote a postcard to Norman Oliver, asking him if he knew anything else about the case. I don't recall the sequence of events, but evidently he was contacted by Brenda Butler or Dot Street shortly after hearing from me.

"So, as you can see, I have talked to no U.S.A.F. personnel who were allegedly involved with the case. Norman Oliver, Brenda Butler and Dot Street were never given any information which would have allowed them to draw such a conclusion."

I appreciate Lou Farish's frank assessment of his part in the Rendlesham Forest mystery as will other readers of *SKY CRASH*. With all respects to the diligent authors of this book, their early leads after the original disclosure by Steve Roberts six days after the event, were in many cases rumors that required tireless follow-up to determine their authenticity. Lou's note to Norman Oliver was simply another of the many rumors that leaked out early in the investigation. These were some of the threads of evidence which ultimately disclosed and confirmed one of the most important UFO cases in modern history as depicted in *SKY CRASH* and in the recent Cable News Network (CNN)

Special Assignment Program titled "UFO -- The Bentwaters Incident," produced by Chuck DeCaro, that was aired between January 23 and 27, 1985.

Mr. Ted Turner, the owner of CNN and WTBS-TV in Atlanta, Georgia, is to be congratulated for having the foresight and intestinal fortitude to produce such a revealing UFO documentary. This is the type of program that "60 Minutes" or "20/20" would have loved to break to the American public; however, Ted Turner's TV pioneering spirit through the terrific investigative work of Chuck DeCaro made it possible. Larry Fawcett, Assistant State Director for Connecticut and co-author of *CLEAR INTENT*, must receive his earned accolades, since he served as technical advisor and provided the "leg-work" and contacts to Chuck DeCaro which made the film possible.

We invite everyone to write to Ted Turner and express their appreciation for his courageous investigative documentary on the most important scientific mystery of our time — UFOs.



**SAY HELLO, Continued**

discussing such questions with the general public in our effort to inform them about UFO's and modify their general attitude. In the years to come, if we are wise enough to recognize valid information when we get it, our efforts may significantly increase that slice of the pie representing acquired information.

# SIGHTINGS

by Mark Uriarte & Brad Sparks

DATE OF SIGHTING: 29-30 August 1976

TIME OF SIGHTING: Between @ 23:30-00:00 Hours, (@ 11:30p.m.-12:00 a.m.)

TYPE OF SIGHTING: NL that became CE-1 with personal physical effects and possible occupant seen.

DURATION OF SIGHTING: As a NL maybe 30 minutes, as CE-1 @ 20 Seconds

WITNESS NAME: Wayne Singleton

## TELEPHONE TIP

On or about 1 September 1976, I received a telephone call from Mr. Brad Sparks, a University of California Berkeley student and Aerial Phenomena Research Organization (APRO) UFO investigator. Brad informed me of a possible close encounter case in Sonoma, California (located about 30 miles north of San Francisco). After making an appointment with the witness, Brad, who I already knew as a reliable investigator, and I proceeded to the home of the witness, a Mr. Wayne Singleton (age 15). Wayne at the time of the sighting was a junior at a local high school. During our interview Wayne seemed to us an intelligent and inquisitive young man who wanted nothing more than an explanation for what he saw that night of the 29th of August 1976. Actually Wayne believes it may have occurred just after midnight (1202a.m.) on the 30th. Also present during our interview was Wayne's mother who vouched for her son's excitement the night of his sighting. Also partially involved in this case was a man by the name of Joe (no last name was given) who was a family friend with them at the time of the sighting but not present during the interview.

According to Wayne the following is what occurred on the night of August 29-30, 1976, around his home in Sonoma, California.

## NOCTURNAL LIGHT

On the night of the 29th, Wayne had gone to bed at about 2200 hours (10:00p.m.) P.S.T. Now he has a small room with his bed at one corner and a window near the head of the bed. The window looks out to the back of the house which is small and only one level. The area behind the house is an open flat area that reaches out to the hills in the west about 1-1½ miles away. Near the back of the house is a corral which they own. Also west of their house in the open area are some small buildings which they do not own. At around 2300 hours (11:30p.m.), Wayne states that he awoke and for no reason he just got up and started looking out the window to the hills in the west. There he saw over the hills and slightly to the southwest of his window and viewing point a blue light that he states was moving up and down 'all sorts of ways'.

After looking at this light for an uncertain period of time (he felt the whole sighting from when he first saw the NL to when he last saw the object close was 30 minutes), he then noticed to his right and slightly to the northwest of his window 3 small red lights that appeared close together and which appeared to be over another hill. As he noticed these red lights they started moving closer to him. The closer they got the lighter in color they got. There was no noise coming from any of these lights.

Finally the lights had moved to where they were almost over him at which point they now turned white in color. He was now looking straight up at the lights for they had now stopped above him. To view the lights which was now really an object with form, he had to get down below window level and

look straight up. He estimated that while it had stopped to hover he had it in view for at least 5 seconds and perhaps as much as 10 seconds. From over the hill where he had first seen the red lights to hovering overhead was around another 5 seconds. So the total viewing time of the red lights was about 15 seconds.

Now that the lights or object was over his window he saw the following:

The object appeared oval in shape, though he was not sure for the outline was barely discernible. Perhaps slightly similar to a football. There were also 2 large windows slightly separated from each other in the middle of the object. There was a dark or black rim around the windows and the inside was white or there was a white light from within the windows. To his right he saw a sort of spotlight (the object's left side?), pointing down at him. He said it looked like a sort of flashlight or dentist's light, yet there was no real light on him. He pointed out that at one point when the object was coming towards him he saw in one of the windows a dark or black stick or peg he thought maybe a figure. However, by the time the object had come close enough to where it reached or passed the point of the corral nearby, it was gone. It was in other words, gone by the time it had reached its closest point to the house. Wayne also said, that at the point where the object was coming towards him and when it was just over the corral, he called out to his sister, Cindy, who was in the next bedroom. However he claims that when he called out to her he could not hear his voice, as though his voice did not carry in the air. In short he heard no sounds at all. Wayne also claims that while he was staring at it, he felt hypnotized by it. Then all of a sudden it took off over the house in an easterly direction. He then ran into his mother's room and woke her up.

(continued on next page)

## SIGHTINGS, Continued

Upon telling his mother what had happened, they went outside to see if it was still in the area. However there was nothing there; even the blue light in the southeast was gone now.

### PHYSICAL EFFECTS

Later we learned that there is a kennel nearby and that the dogs were barking at roughly the same time of the sighting. Wayne described his reactions during the sighting as nervous, an odd body shake overcame him and the feeling of slow motion when he tried to move. Also we learned that earlier at around 11:00p.m., Joe had gone outside and while outside noticed that the static electricity in the air was causing his body hair to stand-up.

On the standard form that Wayne filled-out, he stated that the size of the object was larger than a Cadillac car when it was at its nearest point or just above him. At its farthest point it appeared as a pinhead held at arms-length. The weather was clear with no moon out at the time. Wayne also felt that when the object was hovering over the window, it was at an angle and

therefore this accounted for why he could only see the front panel and windows.

Speculating later, Wayne's mother felt that perhaps the blue light seen early in the sighting was a light being used by hunters who sometimes go up into the hills at night because it is illegal to hunt there. Both Brad and I discounted this explanation because of the light's unusual movements as stated by Wayne, and that the light was above the hills instead of in them.

### CONCLUSIONS

It should first be pointed out that Wayne seemed to both Brad and me a sincere and honest young man. He gives no impression of being a hoaxer.

Wayne also did not show any real previous knowledge of the subject of UFO's. He stated that even though he had a book on UFO's 'Beyond Earth, Mans Contact with UFO's', he had never read very much of it. He claims to have purchased the book sometime earlier (months?) from the date of the sighting.

As per my request, I received from Wayne about a week or so later, a letter or write-up in his own words about his

sighting. In the write-up Wayne states in reference to his getting up to look out the window, "I got back-up and started looking out the window. I didn't know why I was doing this, for I never do this."

Wayne also claims in his letter to me, that on the Friday after the interview he and his mother saw what they believe to be a UFO. That it had 3 red lights, but in a different order than the UFO he first saw.

This area of northern California (Sonoma County) is known for its occasional UFO sighting. After weighing all the information as well as reaction and attitude of the witness and family, it is the view of the investigators that a real incident occurred and basically as described by Wayne. We leave it up to the reader to make up his/her own mind. Any questions, comments and arguments that the reader may have on this case the investigators will be most glad to hear from. Also any other similar cases that the reader may be aware of that the investigators are not, the investigators would like to hear about them.

---

-investigated by **MARK A. URIARTE**  
and **BRAD SPARKS**

**DATE OF SIGHTING:** July 25, 1977

**TIME OF SIGHTING:** 0305 Hours

**LOCATION:** San Francisco Marina  
along San Francisco Bay

**TYPE OF SIGHTING:** CE-1

**DURATION OF SIGHTING:** 20 Minutes

**WITNESSES NAMES:** Bryant and  
Mimi Beckett

This case was brought to my attention on 26 July '77, by a member of Amalgamated Flying Saucer Club of America who at the time resided in Berkeley, Ca. The witnesses who received no cooperation from the local police found the phone number of AFSC in the phone book. I was notified by the local Amalgamated representative and asked to investigate the case.

I will break this report into three

parts. First the witnesses' narrative of their experience, then background information on the witnesses and finally other pertinent data and my conclusions. The witnesses are married. Bryant possesses better eye sight than his wife Mimi, who at the time of the sighting did not have her glasses which she needs to see distances. Bryant therefore did most of the talking during the interview. Much of their story comes from him therefore.

### CONE-SHAPED

Bryant who works late hours (he comes home after 2a.m.) and his wife decided to get something to eat at a nearby fast food restaurant that is open 24-hours a day. However, instead of eating there at the restaurant they decided to park along the San Francisco Marina and eat. The time was about 3:05 a.m. when he finished eating. Their car was facing San Francisco Bay with the weather in the

vicinity fairly clear, though most of the rest of San Francisco was fogged in.

As he finished eating he began to light a cigarette when he looked up at the windshield and all of a sudden he noticed this object or light coming straight down over the area of Angels Island about 2½ miles from the marina and the mainland. He thought it must have been moving 250 mph or more and that it looked like something that had been thrown straight down. It looked like it was going to crash into the water when all of a sudden it stopped. It did not bounce or anything as he put it, just a quick dead stop. After it had stopped it began to "kind of bounce" in the air and proceeded to move off at perhaps 15-20 mph. No noise was heard at all up to this point or at any time during the sighting. Also no exhaust or trail was noted. Bryant felt no one would have known it was there unless "you had seen it come down." In short the object

(continued on page 12)

'Despite a massive cover-up, News of the World investigators have proof that the mysterious craft came to earth in a red ball of light. An American airman who was there told us there were three beings in silver space suits aboard the craft. . . . More seriously, they produced a supporting statement from a named American Air Force colonel, which we reprint on the right. And an American UFO expert who said 'You can't hide the truth for ever.' Which is where Ian Ridpath takes up the investigation.

## A flashlight in the forest

FOUR Christmases ago, something remarkable was said to have occurred outside the US Air Force base at Woodbridge, near Ipswich. News of the event leaked out slowly, finally hitting the headlines in October 1983: "UFO Lands in Suffolk — Official," screamed the front page of the News of the World.

The story was sensational. It told of a group of American airmen who were confronted one night with an alien spaceship in Rendlesham Forest, which surrounds the air force base. According to the story, the craft came down over the trees and landed in a blinding explosion of light.

The airmen tried to approach the object, but it moved away from them as though under intelligent control. The following day, landing marks were found on the ground, burns were seen on nearby trees, and radiation traces were recorded. There was even talk of aliens aboard the craft, and allegations of a massive cover-up. It had all the ingredients of a classic UFO encounter.

The News of the World's informant was a former US

airman. He was given the pseudonym Art Wallace, for he claimed that his life had been threatened if he talked. Yet here he was freely giving interviews to newspapers and television.

While his fantastic story might be doubted, it was impossible to shrug off a memo written by the deputy base commander, Lt. Col. Charles J. Halt, to the Ministry of Defence, which was publicly released in the United States under the Freedom of Information Act. Halt's memo, reprinted in full here, is not as sensational as Wallace's story, but it is prime documentary evidence of a type rarely encountered in UFO cases.

UFO researchers in Britain could scarcely believe their luck: this was The Big One, final proof that We Are Not Alone. The News of the World paid £12,000 for the story. A book was recently published about the case, and American TV crews have been filming at the site in recent weeks.

All that evidence, backed up by the word of the US Air Force, could not possibly have a rational explanation.

Or could it? Here are the facts that you have not been told.

Soon after the News of the World story appeared, I went in search of local opinions about the case. I made contact by telephone with a forester, Vince Thurkettle, who lives within a mile of the alleged UFO landing site. "I don't know of anyone around here who believes that anything strange happened that night," he told me.

So what did he think the flashing light was in Rendlesham Forest? I was astonished by his reply. "It's the lighthouse," he said.

That lighthouse lies at Orford Ness on the Suffolk coast, five miles from the forest. Thurkettle plotted on a map the direction in which the airmen reported seeing their flashing UFO, and found that they were looking straight into the lighthouse beam.

Could this really be the answer? I visited the site with a camera crew from BBC TV's Breakfast Time. On the way there, the cameraman was sceptical about the lighthouse theory. I didn't blame him.

It was gone midnight when Vince Thurkettle took us to

the site of the alleged landing, and it felt spooky. The area had by now been cleared of trees as part of normal forest operations, but enough pines remained at the edge of the forest to give us a realistic idea of what the airmen saw that night.

Sure enough, the lighthouse beam seemed to hover a few feet above ground level, because Rendlesham Forest is higher than the coastline. The light seemed to move around as we moved. And it looked close — only a few hundred yards away among the trees. All this matched the airmen's description of the UFO.

The conclusion was clear. Had a real UFO been present as well as the lighthouse, the airmen should have reported seeing two brilliant flashing lights among the trees, not one. But they never mentioned the lighthouse, only a pulsating UFO — not surprisingly, since no one expects to come across a lighthouse beam near ground level in a forest.

So startlingly brilliant was the beam that the television cameras captured it easily. The formerly sceptical

Colonel Charles Halt's memo on official American Air Force notepaper was headed "Unexplained Lights", dated 13 January 1981, and sent to the RAF. It said:

1. Early in the morning of 27 Dec 80 (approximately 0300 L), two USAF security police patrolmen saw unusual lights outside the back gate at RAF Woodbridge. Thinking an aircraft might have crashed or been forced down, they called for permission to go outside the gate to investigate. The on-duty flight chief responded and allowed three patrolmen to proceed on foot. The individuals reported seeing a strange glowing object in the forest. The object was described as being metallic in appearance and triangular in shape, approximately two to three meters across the base and approximately two meters high. It illuminated the entire forest with a white light. The object itself had a pulsing red light on top and a bank(s) of blue lights underneath. The object was hovering or on legs. As the patrolmen approached the object, it maneuvered through the trees and disappeared. At this time the animals on a nearby farm went into a frenzy. The object was briefly sighted approximately an hour later near the back gate.

2. The next day, three depressions 1½" deep and 7" in diameter were found where the object had been sighted on the ground. The following night (29 Dec 80) the area was checked for radiation. Beta/gamma readings of 0.1 milliroentgens were recorded, with peak readings in the three depressions and near the center of the triangle formed by the depressions. A nearby tree had moderate (.05-.07) readings on the side of the tree toward the depressions.

3. Later in the night a red sun-like light was seen through the trees. It moved about and pulsed. At one point it appeared to throw off glowing particles and then broke into five separate white objects and then disappeared. Immediately thereafter, three star-like objects were noticed in the sky, two objects to the north and one to the south, all of which were about 10 degrees off the horizon. The objects moved rapidly in sharp, angular movements and displayed red, green and blue lights. The objects to the north appeared to be elliptical through an 8-12 power lens. They then turned to full circles. The objects to the north remained in the sky for an hour or more. The object to the south was visible for two or three hours and beamed down a stream of light from time to time. Numerous individuals, including the undersigned, witnessed the activities in paragraphs 2 and 3.

  
CHARLES T. HALT, Lt Col, USAF  
Deputy Base Commander

cameraman was convinced. My report was shown the following morning on Breakfast Time, much to the dismay of UFO spotters and the News of the World reporter.

The lighthouse theory soon had its supporters and its detractors. But there were still too many open questions for the case to be considered solved. For instance, what about those landing marks?

Some weeks later I returned to Rendlesham Forest in search of answers. The landing marks had long since been destroyed when the trees were felled, but I now knew an eyewitness who had seen them: Vince Thurkettle. He recalled for me his disappointment with what he saw.

The three depressions were irregular in shape and did not even form a symmetrical triangle. He recognised them as rabbit diggings, several months old and covered with a layer of fallen pine needles. They lay in an area surrounded by 75ft tall pine trees planted 10ft to 15ft apart — scarcely the place to land a 20ft wide spacecraft.

The "burn marks" on the trees were axe cuts in the bark, made by the foresters

themselves as a sign that the trees were ready to be felled. I saw numerous examples in which the pine resin, bubbling into the cut, gives the impression of a burn.

Additional information came from other eyewitnesses — the local police, called to the scene by the Woodbridge air base. The police officers who visited the site reported that they could see no UFO, only the Orford Ness lighthouse. Like Vince Thurkettle, they attributed the landing marks to animals. The case for a landed spaceship was looking very shaky indeed.

What had made the airmen think that something had crashed into the forest in the first place? I already knew from previous UFO cases that a brilliant meteor, a piece of natural debris from space burning up in the atmosphere, could give such an impression. But I was unable to find records of such a meteor on the morning of December 27.

Here the police account provided a vital lead by showing that Col. Halt's memo, written two weeks after the

event, had got the date of the sighting wrong. It occurred on December 26, not December 27.

With this corrected date, I telephoned Dr John Mason, who collects reports of such sightings for the British Astronomical Association. He told me that shortly before 3 am on December 26 an exceptionally brilliant meteor, almost as bright as the full moon, had been seen over southern England. Dr Mason confirmed that this meteor would have been visible to the airmen at Woodbridge as though something were crashing into the forest nearby. The time of the sighting matched that given in Col. Halt's memo.

Finally, I turned to the question of the radiation readings. I learned that readings like those given in Col. Halt's memo would be expected from natural sources of radiation such as cosmic rays and the earth itself. In short, there was no unusual radiation at the site.

As for the star-like objects in the final paragraph of Col. Halt's memo, they were probably just that — stars. Bright celestial objects are the main

culprits in UFO sightings, and have fooled many experienced observers, including pilots. The object seen by Col. Halt to the south was almost certainly Sirius, the brightest star in the sky.

If it seems surprising that a colonel in the US Air Force should identify a star as a UFO, consider the alternatives. Is it likely that a bright, flashing UFO should hover over southern England for three hours without being spotted by anyone other than a group of excited airmen? And if Col. Halt really believed that an alien craft had invaded his air space, why did he not scramble fighters to investigate?

UFO hunters will continue to believe that an alien spacecraft landed in Rendlesham Forest that night. But I know that the first sighting coincided with the burn-up in the atmosphere of an exceptionally bright meteor, and that the airmen who saw the flashing UFO between the pine trees were looking straight at the Orford Ness lighthouse. The rest of the case is a product of human imagination.

## SIGHTINGS, Continued

moved so slowly that it blended into the background so that unless you stared at it for at least several seconds you would not have noticed it.

As for the object, it was cone-shaped and it had yellowish-white lights at the bottom moving left to right, and about 1/3 of the way up it had red lights all the way around it; they were also moving left to right. The color of the craft was grayish-black (how he could tell its color from a distance of 2 miles or so he did not explain). Bryant estimated that as the object began to move it was 20-30 feet above the water. During the entire sighting it never changed its height much. The object moved off towards the Marina side of the bay near Sausalito. It appeared to move around the coastline of the bay. As the cone-shaped object took-off (with the rounded point upwards) the top part of the cone opened up at an angle and as Bryant put it, "a kind of lighted ball came to the top from within the object.

The ball then rested on the top." They do not know if the ball was directly connected to the rest of the object by anything. When the ball came out it was already spinning in a right to left direction.

The little ball also had a band of lights around its middle which were yellowish-white in color and spinning in a right to left direction. Bryant described the ball like "a big fortune teller's globe that was lighted up and kind of cloudy." The little ball appeared to be about 1/3 the size of the top half of the cone (he never did try to give an estimated size to the object overall). While this was happening the entire object was moving and at times it stopped or hovered. The object proceeded to move around the perimeter of the Marina side of the Bay (north of their viewing position).

The object seemed to follow the lights along the shore. When it entered a dark area it appeared to speed up to the next light along the shore at which it would then slow down again. It followed this same pattern moving overall in a westerly direction until it reached the north end of the Golden Gate Bridge. It then proceeded to move along under the bridge until it reached the San

Francisco side (the south end of the bridge). While moving under the bridge it did stop once (perhaps to take in the view?) and then proceeded on to the S.F. side.

All the time the little ball never left the object and it always remained spinning. Once the object reached the S.F. side Mimi became frightened and wanted to leave. Bryant on the other hand was very interested and excited by it all but he decided to leave because his wife was getting very upset. From beginning to end the whole experience lasted about 20 minutes until they left.

They did look for people around them as additional witnesses but saw no one at first. When they drove off, they did notice a parked car some distance down the Marina on the other side of a building. They decided to get the attention of a couple inside the car. However when they noticed that the couple were necking, Bryant felt uncomfortable about bothering them so they did not.

Bryant (who spent a short time in the Air Force) and Mimi felt it was definitely not a helicopter (a fairly common sight at times in the area), a plane or any other man-made or natural object. Also Mimi stated that they saw no boat on the bay at any time during the sighting. There were no physical effects on them and they noticed none on the car.

## WITNESSES

Both are friendly and talkative, especially Bryant. Bryant was at the time of the sighting 19 years of age and Mimi appeared to be about 20 (I did not get her age). Bryant was employed full-time as a head bus boy at a major San Francisco hotel. To the best of my knowledge Mimi did not work at the time. He is a high school graduate who has never attended college. Having served a short tour in the Air Force, Bryant claims to be fairly familiar with Air Force aircraft (given his short tour I tend to believe he is only very limited in his familiarization of Air Force aircraft). Both had only a minor interest in UFO phenomena prior to the sighting, even though Mimi admitted to me that she did once read a paperback book about UFO's. She does not remember the

book's title. In short, both witnesses seem fairly intelligent and neither seem likely to be the type to create a hoax. At least to this investigator. They are convinced they did not imagine their experience and that it happened as they described.

## CONCLUSION

The fact that there were no other witnesses to corroborate the event of course keeps this from being a higher caliber sighting. There was a report that someone (male) saw the same or similar object that same early morning. However, all efforts to locate him did not result in success. The local S.F. police stated that no other reports of anything unusual were reported on that day or morning. It should be pointed out that the witnesses did try to first call a local T.V. station in order to report their sighting and see if anyone else might have seen it.

The station stated it received no other reports, however, someone from the station might call back in order to setup an interview with the witnesses for a later broadcast. Bryant then called information and received a phone number for a local UFO hot-line reporting service (Amalgamated Flying Saucer Club of America).

It should be pointed out that after they reported their experience to the police and one full day after their sighting, the same local T.V. station interviewed the witnesses at the Marina but never aired the interview due to the lack of verification by other witnesses.

Despite the lack of additional witnesses, I am still confident that this case is not a hoax or an example of the witnesses' wild imagination. Cone-shaped UFO's have been reported before. So their description of the object is not totally unique. Therefore, until I receive evidence to the contrary, my final conclusion is that this was more likely the sighting of a real UFO than a misidentified aircraft. I shall leave it up to the reader to make his/her own conclusion as to what was seen.

**MUFON**

103 OLDTOWNE RD.  
SEGUIN, TX 78155

## SIGHTINGS, Continued

DATE OF SIGHTING: Summer 1951

TIME OF SIGHTING: about 12:00 hours or p.m.

LOCATION: Fort Sill, Oklahoma

TYPE OF SIGHTING: Daylight Disc

DURATION OF SIGHTING: less than 2 minutes

WITNESS NAME: Mr. B.W. (witness wishes to keep full name confidential)

### INTRODUCTION

In April of 1976 while attending a lecture being given by noted UFO lecturer Stanton Friedman at San Mateo College in San Mateo, Calif., I meet Mr. B.W. Mr. W wishes his name be kept confidential. Mr. W had briefly related to me a UFO experience he had during the question and answer period of the lecture. Out of interest I went to him for further details. He was kind enough to take the time and related to me the full details of this sighting as best he could remember them. I say this because the sighting occurred in the summer of 1951.

Mr. B.W. is an Aeronautics instructor at the College of San Manteo. He holds a B.S. in economics. He is also a former U.S. Army captain who served in both W.W.II and the Korean War. He is a man who impressed me as very sincere.

### "POLISHED DIME"

According to Mr. W in the summer of 1951, he was serving active duty as a captain in the army at Fort Sill, Oklahoma. Mr. W stated that he was outside on the flight line at about 12 noon, refueling an aircraft, when all of a sudden he caught sight of an object coming from the northeast heading in a southwest direction. The object looked like a dime with a high polish. It was self-luminous and though brighter than the background sky, it was not as bright as the sun. As for its size it appeared as large as a dime held at arms-length. The weather was clear and the winds were

calm. Throughout the sighting the object was sharply outlined against the sky and at no time was any sound heard. The object did not rise or fall while in view as it moved from NE to SW. The object moved rapidly and was therefore in view for less than 2 minutes. There were other witnesses as well and they included one pilot, two mechanics and two tower controllers. Unfortunately, he does not remember their names. Personally, Mr. W was awed at the object's speed, brightness and what he called precision of its heading. Because the object was in observation such a short time, he felt it was very difficult to estimate the distance of the object.

After the sighting, Mr. W stated that army intelligence G-2 at Fort Sill was informed (he does not say by who) of the incident. However their response to his sighting was "he must have had too many the night before."

In reference to physical effects, Mr. W said there were no electrical or physical effects noticed at any time. Of

interest is his comment that he believes the incident occurred the same day as the incident of the famed Lubbock Lights. The Lubbock Lights incident occurred on 31 August 1951. He remembers hearing of the sighting at about the same time as his sighting.

### CONCLUSION

Mr. W gave me the impression of being the type of person one can trust. It is interesting to note that even though he came to hear Friedman's lecture, he still wanted to remain anonymous as far as his sighting is concerned. Though not spectacular, Mr. W's sighting is very typical of the daylight disc type sighting. It is regrettable that he could not remember the names of the other witnesses, especially the two tower-controllers. I accept Mr. W's sighting at face value and leave it up to the reader to make up his/her own mind.

—investigated by Mark A. Uriarte,  
Captain, USAF, MUFON F.I.



LEO  
©

## NEWS'N'NOTES

1-31-85

**MOSCOW (AP)** - Pilots and passengers aboard a Soviet airliner have reported encountering a starlike UFO they said illuminated the ground with a dazzling beam and escorted them to their destination, a Soviet newspaper reported Wednesday.

The newspaper *Trud* quoted a Soviet scientist who specializes in unusual phenomena, including unidentified flying objects, as saying the occurrence was "undoubtedly abnormal."

An Aeroflot domestic flight from the Georgian capital of Tbilisi to Tallinn in Estonia was approaching Minsk when "what appeared to be a large, unblinking star suddenly shed a thin ray of light which fell plumb down to the ground" from an altitude of 25 to 30 miles, the newspaper said.

"Ground control at the time registered splashes on its screens in the same part of air space," *Trud* said. The date of the flight was not given.

Co-pilot Gennady Lazurin told an air controller in Minsk about the sighting and was told at first that nothing could be seen on ground radar, the newspaper said.

"Oh well, they'll be saying we're not normal," Lazurin was quoted as saying.

All four crew members reported that they "could see distinctly everything down in the sector of the ground illuminated by the cone-shaped shaft of light," the newspaper said.

It said the ray suddenly focused on the airplane.

"The pilots saw a dazzling white spot surrounded by concentric colored rings," *Trud* said.

The UFO then reportedly zoomed toward the airliner "at flashing speed," leaving a green cloud in its wake.

The UFO positioned itself beside the plane at an altitude of 33,000 feet and accompanied (sic) it for the rest of

the flight. "like an honorary escort," the newspaper quoted one of the pilots as saying.

Nikolai Zheltukhin, a corresponding member of the Soviet Academy of Sciences and deputy chairman of a state commission on unexplained phenomena, told *Trud* the occurrence "is indeed of interest, although the commission already knows of similar cases."

In 1967, the Soviet Union established a special air force commission to investigate UFO sightings, but few details of its work have ever been released.

Belief in unverified phenomena like UFOs officially has been discouraged in the past, although Soviet news media periodically report unusual sightings.

### UFO FLEET

Buenos Aires woke up in a commotion yesterday morning due to what hundreds of nightwatchers described as a UFO fleet flying over their heads.

The sighting was made in several places of Greater Buenos Aires and in the northern part of the capital, in an E-W direction, a little before 03.00 am, and served as the main topic of discussion to many frustrated tourists at the Retiro bus station, who were left stranded due to a surprise-drivers strike. Gustavo Fernandez, reporting for a radio station on the consequences of the strike, had the satisfaction of transmitting the swift flight of some 15 to 20 circular multicolored objects.

Still surprised, firemen from La Matanza reported next morning what they saw a few hours before: for half a minute the brilliant fleet crossed the sky emitting intense beams of light in all the colors of the rainbow. Radar units in Ezeiza (international airport - Tr.) did not register anything abnormal.

-*Tiempo Argentino* (Buenos Aires),

2-5-84

### CHALLENGER MISSION?

The strange aerial phenomenon that was seen in the early hours of day before yesterday in different places in the country could have been caused by the disintegration of a communications satellite launched by the Challenger, or by the loosening of the enormous fuel tank — 106 meters in length — that the space shuttle launched into space some hours earlier. Neither is the possibility rejected that the luminous effects seen in our skies were caused by the explosion of a balloon simulating orbiting satellites, also launched by Challenger, in what resulted in the second failure of this mission that began in Cape Canaveral last Friday.

Astronomical observers and space experts agreed in their opinion that the phenomenon that caused a commotion in Santa Fe, Rosario, Cordoba, Greater Buenos Aires, the capital city and La Plata could apparently have been caused by particles from an American communications satellite — the Westar 6 — that was lost and disintegrated when its propulsion system failed.<sup>1</sup>

Scientists from the municipal astronomical observatory in Rosario (Santa Fe province-Tr.) were able to determine the trajectory of what they defined as a "particularly luminous elongated cloud that moved in a W-E, slightly N-S, direction."

The astronomers determined — on the basis of other witnesses' testimonies — that the curious formation was seen at 02.20 am Saturday in Cordoba, at 02.45 am in Rosario, and finally in Buenos Aires at 02.50 am. The objects were also seen in Santa Fe city and in some cities in Entre Rios province.<sup>2</sup>

The path of the alleged UFOs was defined as similar to that of a "meteorite exploding and generating a cloud of

(continued on next page)

## NEWS'N'NOTES, Continued

particles that follow the original trajectory." Investigators estimated that the objects moved at a relatively slow speed, 1500 kph, and determined that the colors were the result of incandescence when the particles passed through the atmosphere.<sup>3</sup>

On the other hand, the chief of the Department of Meteorite Observers from the Civil Center of Space Observers in Santa Fe, Mr. Humberto Capozzolo, denied that what Santo Tome and Santa Fe residents saw were UFOs.

This organization issued a communique stating that what happened Saturday was the re-entry into the earth's atmosphere of a large meteor that moved from North to the SE, leaving behind a 15° luminous trail split into two groups, one formed by some 7 or 10 fragments and the other by 2 or maybe 3.

Capozzolo — who was also a witness — added that the particles moved at a speed of about 12 and 15 kilometers per second and the color of the meteor was orange.<sup>4</sup>

He then stated that this could have been caused by the re-entry into the atmosphere of an artificial satellite or by the loosening of the Challenger's fuel tank; this ship is presently in orbit and NASA informs that they will report about the origin and causes of what happened within the next few hours.

-La Nacion (Buenos Aires), 2-6-84

Notes by Harold Guma, Aerospace Engineer employed by Hughes Aircraft and husband of Jane (Thomas) Guma:

1. The Westar 6 did not disintegrate. At time of launching it did not achieve its proper orbit. It has since been retrieved.

2. Distance from Cordoba to Rosario: 400 km - covered in 25 minutes as per clip Speed as per clip: 1500 kph

1500 kph / .60 = kpm, thus: 400 / .25 = 16 minutes as the time it would have taken the meteor to cover these 400 km, instead of 25 minutes.

3. Distance from Rosario to Buenos Aires: 300 km - covered in 5 minutes as per clip 300 / .25 = 12 minutes, and not 5 minutes.

4. Speed as per clip, taking 15 km per second, would be 900 km per minute and 54,000 km per hour, which would render the phenomenon invisible to the human eye, unless it were flying at a very high altitude, but this in turn would make it impossible to be seen with the bare eye.

Translation: Jane Guma - Simi Valley, Ca.

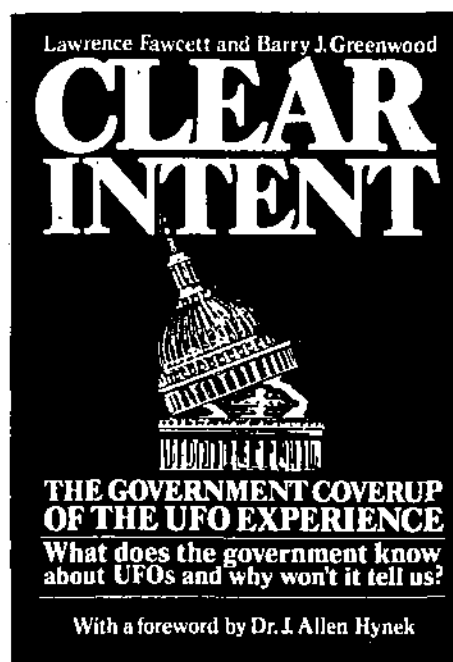

## RADIO NET

Joe Santangelo (N1JS), the manager of MUFON's Amateur Radio Net, recently submitted his annual activity report for 1984. The net meets every Saturday morning at 0800 Eastern Time on 7237 kilohertz. In addition to Mr. Santangelo, we want to thank Leslie Varnicle (WA3QLW) and David L. Dobbs (K8NQN) for sharing net control responsibilities throughout the year. The purpose of the net is to share UFO reports, disseminate news or upcoming TV and radio UFO programs, new books and publications, announce planned MUFON symposia, conferences, and public relations activities.

The inconsistent skip distance occurring at net time throughout the year was a detriment to good communications, plus the heavy influx of ham radio stations operating near the net frequency on Saturday mornings. Many personal friendships have been stimulated between operators checking in on this net on a weekly basis.

The popularity of the net may be measured by the weekly statistics. The largest number of stations reported in (16) on March 24th, the smallest (6) on June 9th, whereas the annual average exceeded ten per week. The following amateur radio stations participated on a regular schedule of districts.

### DISTRICTS

FIRST	SECOND	THIRD	FOURTH	FIFTH	SIX & SEVEN	EIGHTH	NINE & ZERO
N1JS	WB20GS	WA3QLW	K4HXC	W5UAA	W6LTP/7	KNQN	WAOBN
W1LHV	WA2IUI	K3HWH	WA4NKZ	WA5CTJ		W8ZDX	NOCIS
N1BDC	WA2VBT	W31KG	WA4RPU	K5WLT		KA80GF	WB9QQH
K1AJL	N2EQL	WB3AMR	N4JUB	KA5RRL		KA8RWM	KAOLYY
	N2EPG	N3BBI	W4SKE			WD8PLP	WOAJA
			N4FSZ			K8ZDZ	KAODIG

# LETTERS

Dear Editor,

On December 8, 1984, I interviewed Mr. Donald A. Pratt of North Bennington, Vermont, concerning a very interesting event during World War II which both he and several thousand others witnessed. The following is my documented report of the interview I had with him: Please note that this incident happened some forty years ago, and although Mr. Pratt remembers much of what happened that day, there are still a few details, which because of the time span, he has forgotten.

In mid-March of 1945, the battleship U.S.S. *New York* was in the South Pacific, in the area of the Admiralty Islands. The ship had just spent three weeks there making repairs on damage it had received earlier during the battle of Iwo Jima. The *New York* was accompanied by two destroyers as escorts.

Cpl. Donald Pratt was aboard the battleship as part of the FMF PAC (Fleet Marine Force Pacific). The weather that day was warm, very sunny, and clear. The ship and its escorts were on their way to join up once again with the Seventh Fleet.

## ALERT

Suddenly, during the early afternoon, around 1300 hours the ship was called to "General Quarters." Every man ran to his battle station thinking that this might be a Japanese suicide attack. Everyone was in position, all guns were manned and ready. Cpl. Pratt at the time was a gunner on one of the ship's 40 mm gun mounts. All hands waited at their battle stations for something to fire at since the sky was clear as far as the eye could see. Within the ship's radar room a single distinct blip had appeared out of nowhere on the radar scope. A few seconds later the blip became visible in the sky almost directly over the battleship where it hovered, motionless.

By this time, the ship's Capt. K.C. Christian was out on deck observing the object through binoculars. It wasn't

long before most of the ship's two thousand personnel were also observing it, either through binoculars, or with the naked eye.

The object was described as being silver in color, and very shiny. It was much larger than what the brightest star would be at night, but smaller than a full moon. There was no noise that anyone could detect; it did not change color, split up, or perform any erratic maneuvers, but remained above the ship, matching its speed and course.

## WAR NERVES?

After about a half-an-hour had passed, Capt. Christian and many members of the crew were getting a bit nervous. Was it a Japanese trick, or some new kind of weapon? Capt. Christian didn't know, and wasn't going to take any chances. He ordered two of the ship's 3-inch anti-aircraft mounts to open fire on it. For about the next half-hour the 3-inch guns hammered away at the object, but to no avail. It must have been out of their range because the shells did not seem to be reaching it. Later it was learned, that at that time, the object was at an altitude of twenty thousand feet.

Finally, Capt. Christian ordered the guns to cease firing. The object remained above the ship for a few more seconds, then, to everyone's amazement, it climbed up at a fantastic rate of speed until it was out of sight, and off the radar scope. Everyone aboard the ship was stunned by this because they had never seen anything like it before.

I asked Mr. Pratt if the men on the destroyers had seen it too. He replied that they must have....they must have wondered what the firing of the 3-inch guns was all about.

I then asked him what happened, if anything, after the object departed. He said that they were secured from General Quarters, and went back to their normal routine, but it was the talk of the ship for days thereafter. Nobody to his knowledge was told to keep the matter hush-hush nor made to sign any forms pertaining to what they had observed.

"UFOs were not very well known back in those days," Mr. Pratt

explained to me, "You just didn't hear anything about them....or very little. Besides, everyone was preoccupied with the war that was going on at the time. Anyhow, we knew, after watching it for a few minutes that it was not any type of a plane because our ship was only traveling at around twelve knots. An airplane could not travel that slow without stalling and falling into the ocean. It was too sunny and bright to be a star, and it was not a balloon, not in the middle of the Pacific. We didn't know what it was."

Mr. Pratt did mention to me that years later, when he was once again a civilian, he remembers reading a magazine article describing the incident. Also, years after that they had a discussion about it and some other sightings on a television talk show, but he doesn't remember what show it may have been. From these two instances, however it is clear that what took place that day aboard the U.S.S. *New York* was not kept secret.

All Mr. Pratt knows for sure is that they did see the object; it was picked up on radar; they did fire at it with no success; it went straight up and out of sight when it left, and it did not cause any damage, abnormalities, or harm to the ship's equipment, or personnel.

Respectfully submitted

Stephen A. Pratt

(son of Mr. Donald A. Pratt)

*(We appreciate Stephen's efforts. While such anecdotes do not qualify as hard evidence, we print this one in the hope that more data may be forthcoming — Editor)*

Dear Editor,

After reading the article "Towards Truth" (*MUFON Journal*, Dec. 1984) I was quite surprised at the position Coral Lorenzen seems to have taken toward other UFO organizations, and the "pit" which APRO seems to be falling into because of this (my own words). I had always considered APRO to be one of the leading UFO groups in the nation, however, I can see that I was a bit mistaken. It sounds to me that Mrs. Lorenzen is in a desperate race with other UFO groups, a race which

*(continued on next page)*

## LETTERS, Continued

she herself has started and is participating in: Even if she has to break arms, legs, or even relationships with others, she is determined to beat everyone to the "buck." It's too bad because not only is she hurting APRO and giving herself a bad name, but in certain ways this gives UFOlogy a bad taste in it's mouth, so to speak. In order for any organization to survive it must have leadership, respect, and interest in the subject matter which it will be working with. Take away any of these qualities and you break the foundation which holds that organization together. Mrs. Lorenzen....your foundation is breaking!

As to the remark about Mr. Andrus being a pest and a nuisance, but not a threat: If this is so then why does Mrs. Lorenzen mention it? She must be threatened or afraid of something to be putting up such offensive tactics. I have always learned through life that you can accomplish much more together as a group than by being at one another's throats. During the time I have been with MUFON and on the many occasions I have had the pleasure of talking with Mr. Andrus and other fellow members, I have always found them to be courteous, intelligent, and always willing to help in any way they can. We have leadership, respect, interest in our organization, Mrs. Lorenzen. We are solid and you cannot hurt us. Can you truthfully say the same for APRO?

**Steve Pratt**  
North Bennington, VT

Dear Editor,

I enjoyed reading the article in the December issue of the *MUFON JOURNAL*, entitled "The Earth Light Engima," by Hilary Evans. I believe UFO researchers are beginning to fit the pieces of the UFO jigsaw puzzle together. But, it seems they often come to conclusions which tend to show that UFOs are not extra-terrestrial spacecraft, but either or both the effects of natural phenomena, or illusions in the eye of the beholder — that is, psychological or parapsychological in nature. This, of course, follows the pattern throughout human

history, where man has tried to explain the unknown by attempting to fit it within the parameters of the known.

I would like to suggest another approach. Most scientific discoveries have been preceded by hypotheses promulgated by researchers, trying to explain unknown phenomena. A good illustration is Einstein's Theories of Relativity. So, let us assume, or hypothesize, that UFOs are, truly, extra-terrestrial vehicles, manned by intelligent entities. Then, we must ask, how come some observers see them, and many others do not? Mr. Evans, in his article, indicates electromagnetic energy is often correlated with the appearance of UFOs. May I suggest that when there is sufficient electromagnetic energy created, such as with an earthquake — or as in the so-called Philadelphia Experiment (as related by William Moore, in his excellent book entitled "The Philadelphia Experiment") — the spacetime continuum in which we live is affected in such a way that we can see, at least partially, into another dimension. So, when a daylight-disc, a night-light, or a truly nuts-and-bolts UFO vehicle is sighted, could it not be that man is really seeing extra-terrestrial vehicles, due to the electromagnetic disturbance of the spacetime medium in the area, created either by the vehicle itself, or due to some outside source, such as an earthquake, or degaussing generators? The Quantum-Theory of matter deals with Spacetime. An excellent book on this subject has been published entitled "Other Worlds," by Paul Davies, through Simon and Schuster. Here Mr. Davies tells about how spacetime can be warped and twisted and affected by high electromagnetic energy levels. Dr. Rutledge took photos of night-lights and made scientific observations of them at Piedmont, Missouri, an area, which, I believe is very near an earthquake fault.

If my hypothesis is correct, then we have something we can conduct experiments on — the effect of EMF on spacetime, or, more specifically, its effect on: 1) the visibility of spacecraft, its effect on gravitation, its effect on malfunctioning of electrical systems, and its physiological effects on humans

when close encounters are reported. This hypothesis has many ramifications, and could lead us to a method of space-travel through other dimensions that would literally put the farthest reaches of our universe at our fingertips.

**-R. Powell Adams**  
Former State Director for Missouri

# Support National UFO Week

---

18-25 August  
1985

---

**Inform Yourself-  
Inform Others!**

## MUFON

103 OLDTOWNE RD.  
SEGUIN, TX 78155

# STARS & PLANETS

By Walter N. Webb  
MUFON Astronomy Consultant

APRIL 1985

## Bright Planets (Evening Sky):

Mars, moving from Aries into Taurus, has lost its brilliant neighbor Venus to the morning sky. The dim red planet can be seen low in the western sky after sunset, setting some 2 hours later in midmonth. It is below the Pleiades cluster during the week of the 21st and near the crescent moon on the 21st and 22nd.

Saturn, in Libra, rises in the ESE some 2 hours after sunset in midmonth. The ringed planet appears near the gibbous moon on the 7th.

## Bright Planets (Morning Sky):

Venus passes into the morning sky on the 3rd. Our brilliant planetary companion slowly pulls away from the sun's glare, becoming visible again very low in the eastern twilight by midmonth. It gradually gets higher in the sky, rising 1½ hours before the sun by the end of the month.

The second brightest planet Jupiter, in Capricornus, rises about 2 AM in midmonth and is low in the SE at sunrise. This largest of planets appears north of the crescent moon on the 13th.

Saturn crosses the southern sky in Libra, standing low in the SW at sunrise.

## Meteor Shower:

The annual Lyrid meteors, extending from about Apr. 19 to 24, peak on the morning of the 22nd at a rate of about 15 per hour. Though the Lyrids are few in number, their brilliance and tendency to leave behind persistent "trains" make up for their paucity.

## Moon Phases:

Full moon — April 5  
Last quarter — April 11  
New moon — April 20  
First quarter — April 27

## The Stars:

The Winter Circle stars slip lower into the west, while the springtime constellations now occupy the eastern half of the sky in midmonth. Leo, the heavenly symbol of spring, stands due south at 9 PM. Look for the lion's prominent "sickle" which, with the star Regulus, resembles a backward question mark. The first half of April holds the distinction of having more first-magnitude stars visible than at any other time of the year. Eleven of these luminaries range across the sky from east to west in the following order: Vega, Arcturus, Spica, Regulus, Procyon, Pollux, Sirius, Betelgeuse, Rigel, Aldebaran, and Capella.

UFO investigators should be alert for the refractive effects of rising and setting bright stars (and planets), especially Vega, rising in the NE about 8 PM in midmonth, and Sirius, setting in the WSW about 10 PM.

## DIRECTOR'S MESSAGE, Cont.

handling in U.S. funds. Foreign subscribers (outside the U.S.A.) must use an International Postal Money Order or a check drawn upon a bank in the U.S.A. for all purchases and membership dues, since collection costs of other checks exceeds the face value of the check. It has become necessary to return all unqualified checks to the sender, since they have no monetary value. An International Postal Money Order is the preferred form of payment and highly recommended as the best method for foreign purchases or membership/subscription dues. Obviously, we will not ship orders of symposium proceedings or books to foreign countries if we do not have a recognized form of payment. Please help yourself and MUFON by using International Postal Money Orders.

\*\*\*

The success of the CNN Special Assignment program "UFO: The Bentwaters Incidents," produced by **Chuck de Caro**, that was aired from January 23 through the 27th, should be acknowledged by a letter writing campaign to **Ted Turner**, President and Owner of Cable News Network. Please address your complimentary letters to Mr. Turner at Cable News Network or WTBS, 1232 Techwood Drive N.W., Atlanta, GA 30318 and encourage him to produce more UFO documentaries of this nature in the Special Assignment department.

The Charles I. Halt tape recording (audio cassette) made in the field during the investigation of the physical traces left after the UFO landing in the Rendlesham Forest (Bentwaters), is now available to interested MUFON members for \$5.00. The tape is 20 minutes in length and may be purchased from Massachusetts MUFON, P.O. Box 176, Stoneham, MA, 02180 (this is the tape shown on the CNN program).



## DIRECTOR'S MESSAGE, Cont.

The MUFON Field Investigator's Manual (Third Edition) has been recognized as a standard in the English-speaking nations of the world: however it will soon be translated into Portuguese by our colleagues in Brazil. Permission has been granted to **A.J. Gevaerd**, MUFON Representative for Western Brazil, to translate this copyrighted manual into Portuguese and make slight revisions in specific Sections to customize them for use in Brazil. We are confident that the caliber of UFO sighting investigations in Brazil will improve immensely if their investigators utilize and apply these techniques to their reporting.

In November of 1984, **Victor Lourenco**, a member in Toronto, Ontario, Canada, translated from the Portuguese UFO sighting reports in Portugal from 1917 to 1984. Many of them had personally been investigated by **Mr. Joaquim Fernandes**, MUFON Representative for Portugal, starting with the Miracle of Fatima. **Mr. Fernandes**, Director of CNIFO, spent six years collecting data that was unknown to the public due to the 50 year dictatorship regime of Salazar in Portugal. Utilizing his Apple II, **Mr. Lourenco** computerized the entire file into English with translation support from **Larry Fenwick**, CUFORN Director. Most of the cases were reported by the media and for such reason precautions should be taken concerning a deep analysis of the phenomenon. Other cases were investigated by know ufologists, such as **Mr. Joaquim Fernandes** and deserve all the necessary credibility.

**Victor Lourenco** is now in the process of translating and computerizing "Humanoids Over the Iberia Peninsula" by **Jose Figueiredo** of CNIFO and "Humanoids In the Iberian Peninsula" by **Cassiano Jose Monteiro** of CNIFO, Comissao Nacional De Investigacao Do Fenomeno Ovni (Portuguese UFO Committee). **Mr. Joaquim Fernandes** sent the second catalog booklet to MUFON, which was published in 1983. We are indebted to each of these gentlemen for graciously sharing their research work with MUFON.



JOAQUIM FERNANDES  
PORTUGAL

\* \* \*

A new magazine titled **THE UNKNOWN** (A magazine whose time has come), by Co-Editors **Jon Violette** and **Stan Mussman**, is now being introduced to the public on a bi-monthly basis. In their advance advertising literature **Jon** and **Stan** have summarized the purpose of **THE UNKNOWN** in the following manner: "It is our nature as intelligent beings to seek knowledge and understanding. We explore new horizons, constantly learning about ourselves and the world around us — in the process we gain a better perspective of our place in the Cosmos.

"**THE UNKNOWN** is a forum created to enhance this perspective by discussing what must be some of the most profound and worthwhile topics of our time. We cover such subjects as UFOs, Life Extension, Psychic Phenomena, the Near-Death Experience, Mysterious Animals, Reincarnation, and more. Our approach is to evaluate these mystifying phenomena through examination of opposing viewpoints. Presenting research and documentation as well as speculative theories pro and con, we offer a publication that is rational and logical, constantly striving to separate fact from fiction.

"You will hear from the most active and experienced scientists,

researchers, and organizations in their respective fields. We feel that all will benefit from this exchange of ideas. To learn of the startling new developments in these areas of research, subscribe today! This magazine will not be available on newsstands so take advantage of this special introductory offer."

Both **Stan Mussman** and **Jon Violette** have subscribed to the **MUFON UFO JOURNAL** and have purchased the **MUFON UFO Symposium Proceedings** as sources of applicable articles. Articles have been submitted by **Stan Gordon**, **Bill Moore** and **Dennis Stacy** for publication prior to the publishing of their first edition. Subscriptions may be obtained by sending a personal check or money order to **THE UNKNOWN**, 4455 Torrance Blvd., Suite 277, Torrance, California, 90503, for one year (6 issues) for \$14.95 or two years (12 issues) for \$27.50 in the U.S.A. (Foreign is \$4.00 extra per year.)

\* \* \*

MUFON has obtained one hundred additional copies of the third printing of **CLEAR INTENT** by **Larry Fawcett** and **Barry Greenwood** (paperback) which are available for \$8.95 plus \$1.50 for postage and

(continued on page 18)

# DIRECTOR'S MESSAGE

by  
Walt Andrus

The MUFON 1985 UFO Symposium will be held June 28, 29, and 30, 1985, at the Chase Hotel in St. Louis, Missouri. For details concerning speakers and reservations, please refer to a separate article in this issue or the February 1985 issue of the *MUFON UFO JOURNAL*. The 1985 Massachusetts UFO Forum is scheduled at the Beverly Golf and Tennis Club ballroom in Beverly, Massachusetts, on Saturday, August 17, 1985, from 1:00 to 5:00 p.m. and on Sunday, August 18th, from 9:00 a.m. to 3:00 p.m. Moderated by Dr. David M. Jacobs, the speakers are Dr. J. Allen Hynek, Budd Hopkins, Barry Greenwood, Dan Wright, David F. Webb, George D. Fawcett, and John Schuessler (tentative).



BUDD HOPKINS

\*\*\*

Marge Christensen, Director of Public Relations, has announced that August 18-25, 1985, has been designated as "National UFO Information Week." All State and State Section Directors should start making specific plans for public UFO exhibits, showing of UFO video documentaries,



DAVID F. WEBB

one-day UFO Conferences, and a news media blitz as a means of public education to the continuing UFO phenomenon — the greatest scientific mystery of our time. Due to the fantastic public relations job that Robert H. Bletchman, State Director for Connecticut, has been doing, he has been added to the P.I.P.E. Committee by Marge Christensen. The other members of the Public Information and Public Education Committee working with Marge Christensen, are Walt Andrus, John Schuessler, Barry Greenwood, Walt Webb, Dan Wright, Paul Cerny, Tom Gates, Tom Deuley, Doub Labat and Dennis Stacy.

\*\*\*

Edward J. Planz, State Director for Alabama, has appointed Edward O. Brown, a State Section Director, to also serve as Assistant State Director. Mr. Brown (N4JUB) has been active in the MUFON Amateur Radio Net each Saturday morning at 0800 Eastern Time on 7237 KHz. The following State Section Directors have been appointed or changed their status: John R. Thomas was promoted and is

responsible for Kleberg and Jim Wells Counties in Texas; David L. Brewer was reassigned to Shannon, Bennett, Washabaugh and Fall River Counties in South Dakota; James C. DeLotel has assumed the responsibility for Clark, Floyd and Harrison Counties in southeastern Illinois; and Shirley C. Fox has accepted the additional counties of Glades, Hendry and Collier in Florida.

\*\*\*

Maria Angela Thomas Guma (Jane Thomas) will continue to translate Spanish to English for UFO sighting reports emanating from South America. Jane was one of the founding members of FAECE (1977) in Argentina and served on their Board of Directors until December 1984. She recently married Harold Guma (KA6NRY) and is now living in Simi Valley, California where she uses her original call letters LU6DSM in the amateur radio bands. Wayne Powell, an architect in Houston, Texas, was designated as a Research Specialist in Theoretical Physics.



GEORGE D. FAWCETT

(continued on page 19)

# MUFON UFO JOURNAL

NUMBER 204

APRIL 1985

Founded 1967

OFFICIAL PUBLICATION OF



MUTUAL UFO NETWORK, INC.

\$1.50

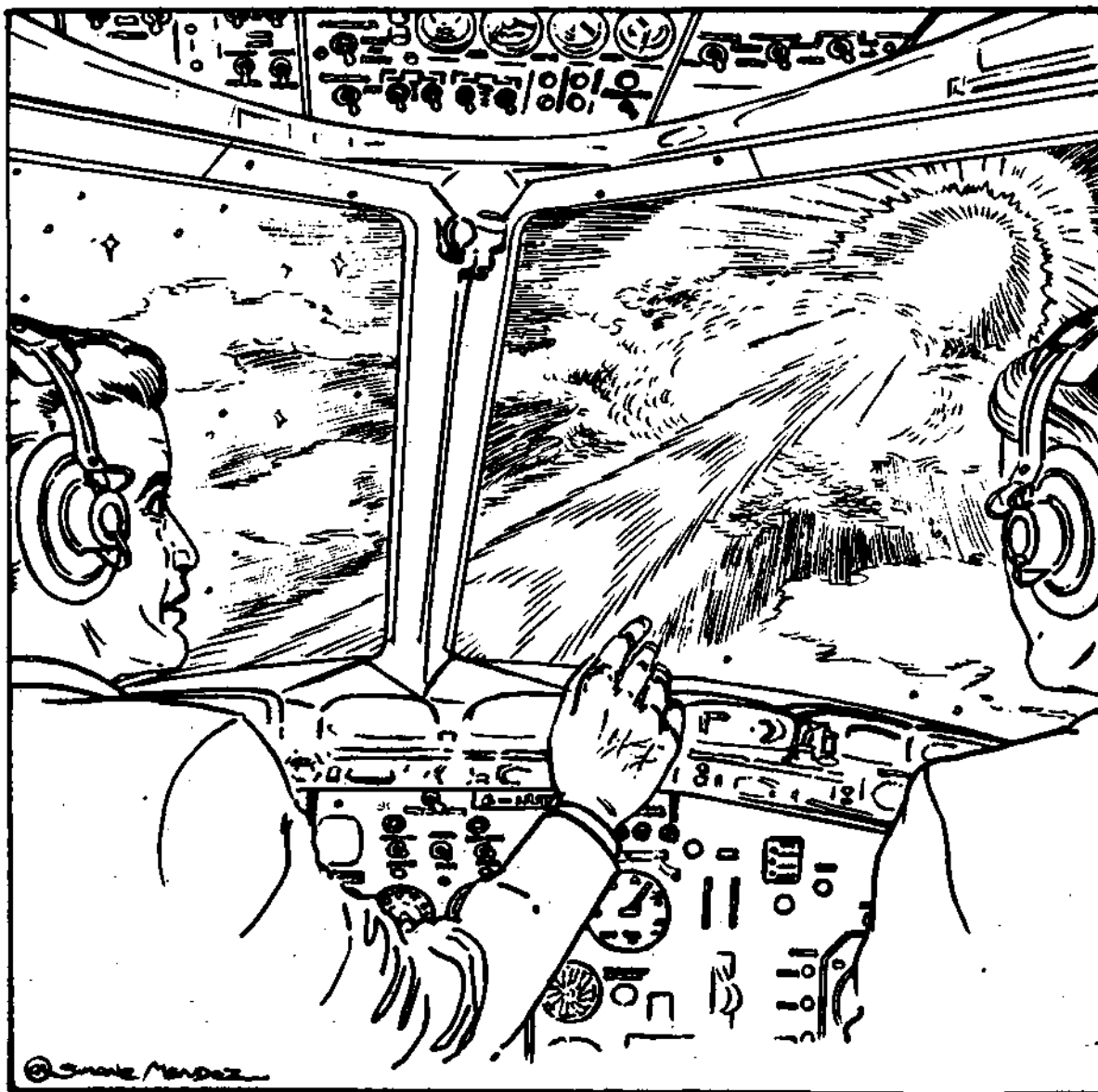

INTERNATIONAL EDITION

**MUFON UFO JOURNAL**  
 (USPS 002-970)  
 (ISSN 0270-6822)  
 103 Oldtowne Rd.  
 Seguin, Texas 78155-4099

**DENNIS W. STACY**  
 Editor

**WALTER H. ANDRUS, JR.**  
 International Director and  
 Associate Editor

**THOMAS P. DEULEY**  
 Art Director

**MILDRED BIESELE**  
 Contributing Editor

**ANN DRUFFEL**  
 Contributing Editor

**TED BLOECHER**  
**DAVE WEBB**

Co-Chairmen,  
 Humanoid Study Group

**PAUL CERNY**  
 Promotion/Publicity

**MARGE CHRISTENSEN**  
 Public Relations

**REV. BARRY DOWNING**  
 Religion and UFOs

**LUCIUS FARISH**  
 Books/Periodicals/History

**ROSETTA HOLMES**  
 Promotion/Publicity

**GREG LONG**  
 Staff Writer

**SIMONE MENDEZ**  
 Staff Artist

**TED PHILLIPS**  
 Landing Trace Cases

**JOHN F. SCHUESSLER**  
 Medical Cases

**LEONARD STRINGFIELD**  
 UFO Crash/Retrieval

**WALTER N. WEBB**  
 Astronomy

**NORMA E. SHORT**  
**DWIGHT CONNELLY**

**DENNIS HAUCK**  
**RICHARD H. HALL**

**ROBERT V. PRATT**  
 Editor/Publishers Emeritus

The MUFON UFO JOURNAL is published by the Mutual UFO Network, Inc., Seguin, Texas. Membership/Subscription rates: \$15.00 per year in the U.S.A.; \$16.00 foreign in U.S. funds. Copyright 1985 by the Mutual UFO Network. Second class postage paid at Seguin, Texas. POSTMASTER: Send form 3579 to advise change of address to The MUFON UFO JOURNAL, 103 Oldtowne Rd., Seguin, Texas 78155.

# FROM THE EDITOR

Our cover this issue, by the talented Simone Mendez, illustrates the widely reported Soviet sighting first made public in late March of this year. The jury on this one is still out; it could be a legitimate UFO or another misidentification of a secret missile launch which so confounds western observers. See "News'n'Notes" for more information.

Inside you'll also find a variety of articles by some of today's leading ufologists that reiterate the worldwide scope of the UFO phenomenon. Most importantly, literally "hot off the press," we have Jenny Randles' update of the ongoing Rendlesham Forest Affair. James Oberg looks at the tendencies of some South Americans to see fire where there is smoke, and Bruce Maccabee begins his own unusual eyewitness account of an even more unusual UFO — a flying "black hole." Leonard Bruce takes a humorous look at E-Tees and Walt Andrus provides the latest information on the upcoming St. Louis Symposium.

Next issue we'll continue Maccabee's detailed analysis and we'll also have an Englishman's argument in favor of the extraterrestrial hypothesis, plus the usual articles and features you've come to expect of the Journal.

## In this issue

<b>RENDELSHAM FOREST UPDATE</b> by Jenny Randles .....	3
<b>KIRTLAND LANDING</b> by Bruce Maccabee .....	9
<b>BLACK HOLE OVERTURE</b> by Bruce Maccabee .....	10
<b>SOUTH AMERICAN "UFORIA"</b> by James Oberg .....	13
<b>CARTOON</b> by Leonard Bruce .....	14
<b>CURRENT ITALIAN SCENE</b> by Edoardo Russo .....	15
<b>NEWSN'NOTES</b> by Dennis Stacy & Walt Andrus .....	17
<b>MAY STARS &amp; PLANETS</b> by Walter Webb .....	19
<b>DIRECTOR'S MESSAGE</b> by Walt Andrus .....	20
<b>COVER</b> by Simon Mendez	

The Mutual UFO Network, Inc. is exempt from Federal Income Tax under Section 501(c)(3) of the Internal Revenue Code. MUFON is a publicly supported organization of the type described in Section 509(a)(2). Donors may deduct contributions from their Federal income tax. In addition, bequests, legacies, devises, transfers, or gifts are deductible for Federal estate and gift tax purposes if they meet the applicable provisions of Sections 2055, 2106, and 2522 of the code.

The contents of the MUFON UFO JOURNAL are determined by the editor, and do not necessarily represent the official position of MUFON. Opinions of contributors are their own, and do not necessarily reflect those of the editor, the staff, or MUFON. Articles may be forwarded directly to MUFON. Responses to published articles may be in a letter to the Editor (up to about 400 words) or in a short article (up to about 2,000 words). Thereafter, the "50% rule" is applied: the article author may reply but will be allowed half the wordage used in the response; the responder may answer the author but will be allowed half the wordage used in the author's reply, etc. All submissions are subject to editing for style, clarity, and conciseness. Permission is hereby granted to quote from this issue provided not more than 200 words are quoted from any one article, the author of the article is given credit, and the statement "Copyright 1985 by the Mutual UFO Network, 103 Oldtowne Rd., Seguin, Texas" is included.

## RENDELSHAM FOREST UPDATE

-by Jenny Randles

I suppose that events since the publication of *SKY CRASH*, by myself, Brenda Butler & Dot Street, must say something about the differences between the UFO movement in both Britain and the U.S.A.

It was a struggle to sell the idea in the first place, both to British UFO researchers and to British publishers. Between 1981, when the three of us first began to chase the case, and August 1983, when we were able to announce the official confirmation breakthroughs on both sides of the Atlantic, Brenda, Dot, and I often felt like lepers. We received no help, no support and our limited personal budgets were dwindling fast.

### REJECTIONS

Similarly, the publisher with whom I have produced three of my most serious UFO books rejected the idea flat, on the grounds that if the events had happened then it would be common knowledge! Likewise, we collected rejection slips like the forest itself collects pine needles in the Fall. Eventually, Neville Spearman, a tiny publishing company with almost no promotional status, took our word for it that there was real evidence. We remain very grateful to them. Even so, working with such a small company has meant that we have had great difficulty promoting what we believe to be crucial questions posed by our manuscript.

Outside of East Anglia itself (see local press articles reproduced in the MUFON UFO JOURNAL issue 201) there has been absolutely no publicity for the case since the book was released in October, 1984. At the press conference, referred to in the "Daily Times" article, no national media sources turned up, despite being invited with a preliminary memo and reminded on the phone. Later, at my own expense, I produced two-page summaries of the conference and sent

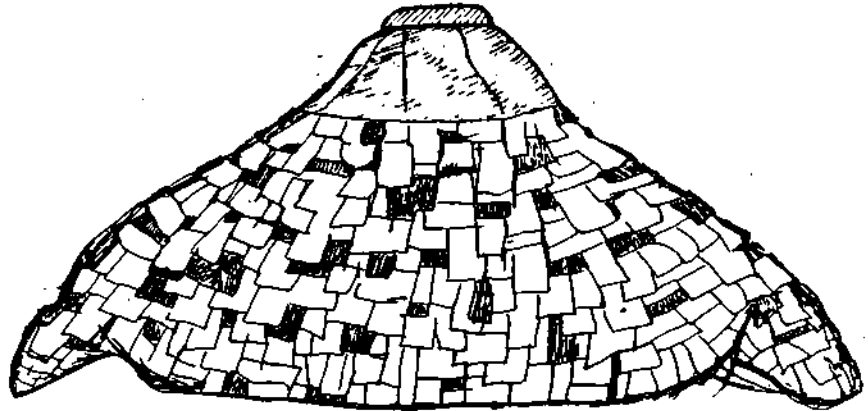

The craft which appeared after the light explosion on 30 December 1980, according to Art Wallace. (Sketched under his direction by Betty Luca.)

them to all national newspaper and television sources. About twenty copies went out in all. *I did not receive a single reply!*

### SECRETS ACT

The British Government can effectively smother press coverage by enforcing what is called a "D" (for Defence) notice. Using our "Official Secrets Act" (a millstone of bureaucratic legislation which can be, and often is, interpreted in whatever way best suits the party in power) the media can be legally restrained from printing anything the government of the day decides to be sensitive on security grounds.

Whether or not a "D" notice was issued regarding Rendlesham Forest is hard to say. We have no real evidence for this statement, but it is exceedingly curious that in October, 1983, the "News of the World" (Britain's largest selling Sunday national) carried four successive articles on the case, including a page-one banner headline, based on a fraction of the material available (chiefly the statements of Larry Warren, alias "Art Wallace," and the Halt memo release). This also led to many subsequent media stories in papers as diverse as "The London

Times" and "The Sunday People" (a contrast not dissimilar to the "New York Times" and "The National Enquirer"!)

Yet the release of *SKY CRASH*, with all its new evidence, has created not even a trickle of media interest. The silence has been deafening.

Unfortunately, as many of the British media sources are owned by big moguls, (often under the influence of "Lord so-and-so") the opportunities for "a quiet word in somebody's ear" are extensive, and all a government really needs to make sure a touchy subject is effectively stifled.

However, the attitude seems to go somewhat deeper into the character of the British; stiff-upper-lip and all that! As I write (March 1985) only two UFO publications have bothered to review the book. One, "QUEST" (about the closest to American thinking published in the UK) went to town. The other dismissed it in a sea of ridicule. This magazine, "MAGONIA," claims the book reflects paranoia, sloppy investigation and total exaggeration of a non-event in the first place. A third publication, from a Nottingham UFO group, has not even reviewed the book. In two sentences it says the case has been explained away as an ordinary

(continued next page)

## RENDELSHAM, Continued

mistake, so end of report. Instead it expounds at length about psychic phenomena!

### BRITISH UFOLOGY

Clearly, this indicates that ufology in Britain has become obsessed with the paranormal and psychological theories, a fault I admit no small level of personal liability towards. Unquestionably, these areas are very relevant to the UFO field. But equally certain, in my view, is the grave danger of leaning so far in this direction that you are running the risk of toppling over the edge of a precipice. American ufology, on the other hand, has overwhelmed us with its enthusiasm for what we tried to do in *SKY CRASH*. It seems that the possibility of government conspiracies finds a home more acceptable in a democratic land which has learned to fight the natural tendency of all bureaucracies to obscure anything problematic.

Yet, this (to us) refreshing approach to undoubtedly serious issues does not seem to be matched by the American publishing industry. As I write, twenty-one USA publishers have rejected the opportunity to publish an edition of our book. Some use the grounds that this is an "English" case (ludicrous because one of our problems in selling the idea over here was that the case was too American!) Others cite the apathy displayed towards ufology these days, a fair (if sad) truth. Yet, by far the most worrying to me, is the attitude expressed in a reader's report sent us by "Prentice-Hall" (probably the most ufo-minded of U.S. publishers). They use this to explain why they rejected *SKY CRASH*.

Now, I make no arguments that the book is the best ever written. I know that is not true. It is confusing and complex. It may even be hard to follow in parts. It does not read like a Spielberg movie. But we, perhaps because we are "Stuffy" English as Prentice-Hall explained, made the absolute decision that we were *not* going to hype-up a space age fairy tale from a potentially explosive case. It would have been easy to do that. To speak in "Gee! Wow!"

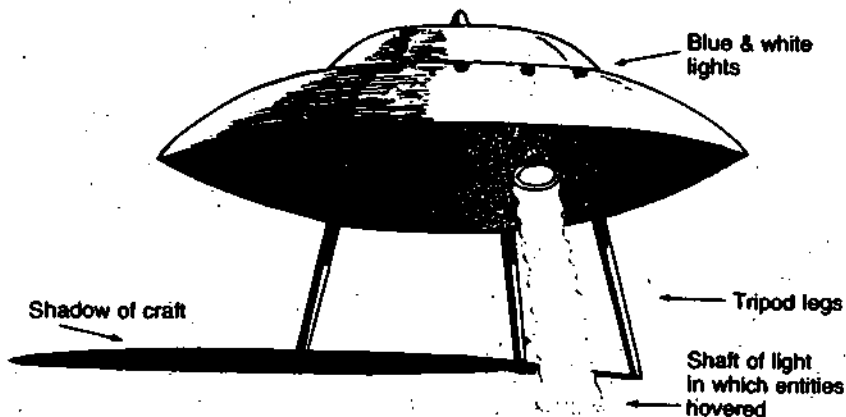

The 27 December 1980 UFO on the ground. Based on a sketch by Steve Roberts.

terms of the awe-inspiring meeting between the aliens and a USAF Brigadier General in a dark, Suffolk wood. But that would have evaded the realities. The only way to honestly set out the facts was to recount them as we uncovered them. We could not possibly tell the story of what happened, other than as fiction, because we even now do not know what happened.

### UFO HYPE

Yet, Prentice-Hall, very disturbingly, said we should have done that. We should have had one answer (presumably that the UFO was a spaceship) and we should have plotted and scripted the book like a novel. As it so delicately puts it, "Gonzo Fans" and "UFO buffs" want mind-blowing facts and an easy, exciting read. It concludes by advising that the company should "Dump these authors!" and rewrite the book from an American point of view.

This, we understand, is precisely what Prentice-Hall plans to do.

Now, leaving aside the enormous expenditure of time, money and effort Brenda, Dot, and I put into our work for *SKY CRASH*, this attitude speaks of a real danger facing the American UFO movement. If this accurately represents the plan Prentice-Hall envisages for future UFO publications, then one has to seriously question the validity of what is likely to appear.

Besides which, we most certainly did not write *SKY CRASH* for "Gonzo Fans," but for any person who cares about the out-of-control nature of western so-called democracies and the

subject disregard being shown for basic rights of citizens.

We elect governments to govern for us, not to do what they like with things such as fact, truth and integrity. It is more important to me than whatever the reality of UFOs turns out to be, that the Orwellian year of 1984 coincidentally saw publication of both "*Clear Intent*" and "*Sky Crash*," demonstrating as they do that Big Brother (or in the UK "Big Sister") is very definitely here.

There has been one British newspaper story about the case, published on 5 January 1985. It was penned by Ian Ridpath (a "space writer" and Britain's CSICOP equivalent of Philip Klass). Ridpath's explanation of the case (a meteor attracting the men into the forest who, disorientated, see a lighthouse five miles away, and later find some rabbit holes and mistake them for landing marks) was elevated to star status very early in the affair. It has had extensive media plugging in the wake of the October 1983 revelations. But there are some rather disturbing aspects to it.

### LIGHTHOUSE

Of course, we knew all about the lighthouse, even before Ridpath conjured it into prominence. It is much the most obvious feature of the environmental lights seen at night from the East Gate of the Woodbridge Base. Nobody on duty there can fail to be aware of it, although it is not visible in

(continued next page)

## RENDELESHAM, Continued

daylight and so the misidentification hypothesis gains credence from that. It is how the lighthouse came to be linked to the case which is to me so intriguing. This is well worth discussing, because (odd as it might be to an American) 90 percent of the British population now believe that the Rendlesham Forest case did not happen, that Ridpath is right, that we are all sensation-mongers, and that USAF forces in Britain are imbeciles, or more accurately, stoned-out-of-their-mind imbeciles.

The theory has, almost single-handedly, ensured that *SKY CRASH* has clocked up practically no sales, and more importantly, that all our calls for serious media enquiries, open public investigations, and questions in the House of Commons, have been totally rejected. Even the UFO committee at the House of Lords have refused to listen to us. It is thus seen to be of grave importance to the future development of the investigation.

Essentially, the "News of the World" featured the case on its front page on 2 October 1983. It immediately created impact on that same day. Within less than 24 hours, remarkable speed for a Sunday when most of the British Press are asleep, the "London Times" (easily the most prestigious newspaper in Britain) had featured the case. The rarity of UFO articles in this newspaper made the event newsworthy in itself. But its dramatic speed and very pointed attitude cannot have been a coincidence.

The "Times" did not talk to Brenda, Dot, myself or the investigative journalists at the "News of the World" who had devoted over two-pages of material to the case. Instead (within a couple of hours of the story breaking) they had gone to East Anglia and filmed a young forestry worker on the site. This man, Vince Thurkettle, was about to be promoted in rank at the office, but at the time was only a junior. He told the "Times" when they came to him that Sunday, it was about time someone thought about an explanation less fantastic than UFOs.

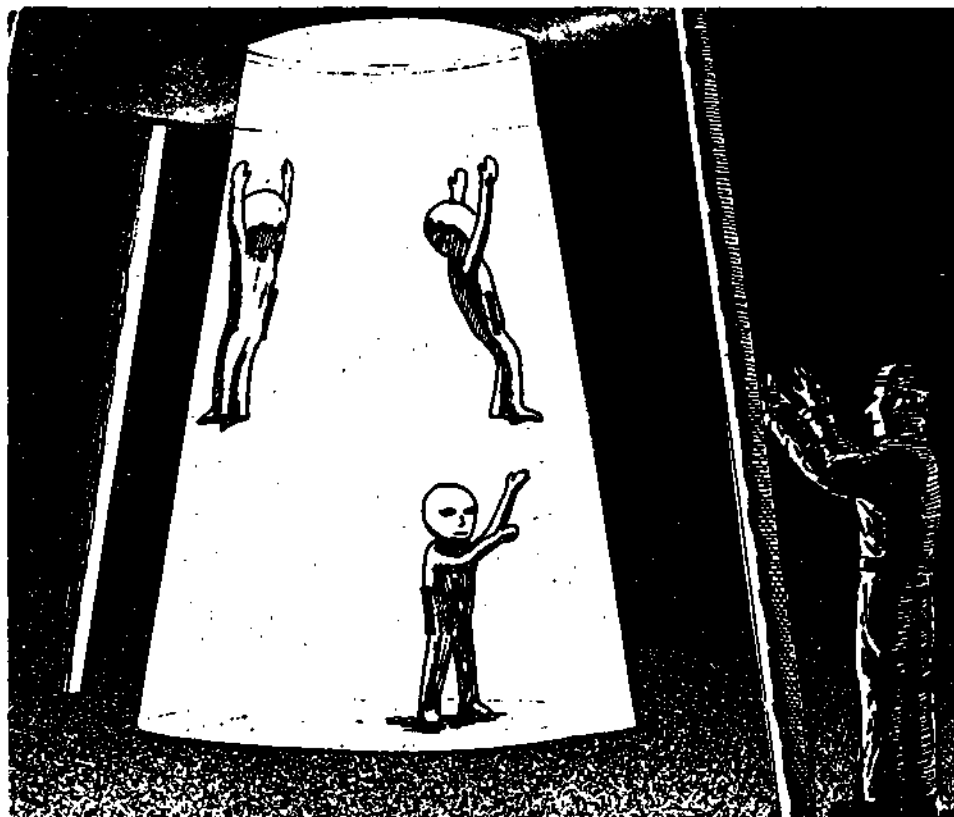

Steve Roberts' view of the alien contact with the Base Commander.

### RABBIT HOLE

Thurkettle noted that about one month after the landing (which he had heard rumours about in the Forestry office) he happened upon some holes in the ground with a giant arrow scratched in the earth pointing at them (this fact has always been omitted from media references, and the time-lag between event and discovery rarely mentioned). These he was told, by some men from the base, were the marks left by the UFO. He examined them and was certain they were scratchings made by rabbits. Droppings were even visible within them.

Armed with this he chanced to notice the lighthouse and pondered if it might have been the UFO. Any dumb Americans who could not tell rabbit holes might not know what a lighthouse looked like. Perhaps they had been brought up in the Nevada desert and had never seen the sea before!

As you can see from this Thurkettle was hardly being over-serious. But his ideas were given huge promotion by the "Times," and were endorsed by every single newspaper which reaches influential sources (i.e.

the less "popular" press, and the ones read by financiers, ministers and civil servants).

I have talked to Thurkettle on the site a couple of times since this dramatic revelation. There is no question that he is less than a hundred per cent convinced by it. He frankly admits that there are puzzles. He accepts the possibility that something else may have been involved. And he talks of his theory as if it "just seemed like a good idea at the time."

He also is worried, as he should be, by the giant arrow in the ground. To me this is so out of phase with the secrecy of the case it strikes me that the most likely scenario is as follows: these marks were concocted around rabbit holes after the events. The men on base were encouraged to believe they were the landing traces to aid in disinformation and to throw the hordes of curious sightseers off the scent. Their later discovery by a forestry worker, and consequent explanation, may have been a planned or unplanned bonus.

Whilst Vince Thurkettle sees this

(continued on next page)

## RENDELESHAM, Continued

himself, the lighthouse/rabbits theory was gratefully seized upon by two different sources.

### BBC COVER-UP?

Ian Ridpath, the anti-ufo debunker, was asked by the B.B.C. (Britain's state owned TV network) to produce an expose of the case. As *SKY CRASH* reveals, in the five days prior to that, a BBC producer we were working with (Doug Salmon) was blocked every which way he went in trying to persuade bosses to let him make a documentary on the case. In the end he put in an official protest and told us that it was clear forces in the upper echelons of the company had conspired against the programme.

Ridpath once more did not talk to any of the investigators on the case before taking a crew out to film the lighthouse with Vince Thurkettle in tow. Instead he used a zoom lens and editing techniques to make the lighthouse look a darned sight stranger than it does - or indeed than it did (because when the events took place the area was masked by a thick blanket of trees, now gone, and the lighthouse was far less prominent than it is in 1985).

"What a shame another UFO case bites the dust" was the way the affair was summed up by the BBC link man. And the shoot-em-down brigade were scoring notable successes in switching public attitudes too.

However, there was a problem for Ian Ridpath. Whilst the lighthouse was a tenable explanation for the "triangular craft" (if you ascribe moronic intelligence to the men involved) he had no idea what they had initially seen crashing into the forest. Even CSICOP draws back from inferring "flight" onto lighthouses, although doubtless James Randi will be figuring out that one for his next trick!

Trouble was, as Ridpath told me after the BBC programme, he could not think of an answer. But, the British bobbies came to the rescue like the cavalry of old. On the day of the original "News of the World" story the head of police in East Anglia had contacted the

local station at Woodbridge and politely advised them they had better have a statement ready to offer the media. This same station had twice denied any knowledge of the case in our previous investigations. Once Brenda and Dot watched them examine their duty book and say there were no reports of UFOs from the base. Now, hey presto!, everything had changed.

A statement offered to the press that first Sunday just happened to include some rather coincidental words. Now they *did* have a report. Two officers had gone out at the request of the base. They saw nothing, only the lights of the Orford Ness lighthouse. Strange that the police should just happen to mention that in their report, is it not? As soon as it got light they went back to the forest and were shown "landing marks," as alleged by the airmen. These, the officers concluded, were marks left by rabbits.

Frankly, I do find it more than a little peculiar that both Vince Thurkettle and the police should independently, and on the same day, end years of silence with this simultaneous conceptual breakthrough about the lighthouse and the rabbits. That smells funny to me. As it should to any half-awake investigative journalist.

But the British police had another crumb of comfort for Ian Ridpath, now crusading widely on behalf of the lighthouse appreciation society. Their records showed the date as 26 December, not the 27th. On this date, so Ian Ridpath triumphantly announced, a bright meteor had been spotted at 0250 hours. Obviously this is what the men saw crashing into the forest, not literally but if you stretch your imagination a bit. Case closed.

### DATES

I have repeatedly asked Ian Ridpath how this date squares with the fact that *none* of the witnesses have ever said it was the 26th (including those talked to within days of the event); that Halt's report itself (based on interviews prior to its dating 17 days after the event) gives the 27th, that the Ministry of Defense in their first public admission to me (13 April 1983) give the date as the 27th, that anyone on duty on

the 26th at 0250 hrs. would likely have begun shifts on the night of Christmas day (a fact likely to be more than usually memorable) and that Halt's report states that the traces were discovered two days after the sighting, not within six hours as police say. Ridpath's only answer to this is that all these people are wrong, otherwise I am accusing the British police of fabricating their records.

Quite honestly, in view of everything else that went on in the wake of the "News of the World" story, I find that position rather more probable than that everybody else got it wrong. It is just too convenient. Again, any half-awake investigative journalist ought to spot these things a mile off. Yet there is a disturbing tendency amongst such people not to do so.

Ridpath still claims, 18 months later, that the case is solved. Chuck de Carro of Cable News Network came to work with Dot and I in December 1984, and rejected all these points flatly, preferring to take the word of the British police (despite a further remarkable coincidence which saw one of the two policemen, who was in the forest in December 1980, interrupt our filming on site four years later and inquire of us what we were doing!).

The lighthouse theory totters on a trip-wire for many reasons. Witnesses were looking in several different directions. Civilians on the road could not possibly see the lighthouse, but they saw the UFO. As the lighthouse stayed where it was *after* the encounter, how come the witnesses describe it as taking off? And so on. There are sufficient fundamental errors in the concept that it is difficult to take it seriously.

What must be added is that regardless of the widespread media support for the theory it has no official backing whatsoever. The British Ministry of Defense still insist the case is unexplained. Current public relations officer at Bentwaters (Captain Victor Warzinski) told me there was never any doubt in the minds of the USAF that something had happened which has not been explained. And all the witnesses involved in the case (from seniors like

(continued on next page)

## RENDELESHAM, Continued

Colonel Charles I. Halt, down to juniors like ex-airman Larry Warren) agree that the idea is stupid.

So why do the media continue to push it? And who do the media refuse to carry any counter articles? Why have I been refused on four separate occasions, since publication of the book, an hour of newspaper time to go (at my own expenses) to London and present the evidence against the lighthouse? I am afraid the answers seem pretty obvious, even if I do risk claims of paranoia by saying so.

The week that our book was released (to nil publicity) another book came out (to quite a fanfare). This one is entitled *Lies! Damned Lies!* and is about unethical journalism. It is penned by a feature writer from the "Times," that same paper which first set the lighthouse on its adventures.

*Lies! Damed Lies!* has sold in great numbers and contains several pages on the case. It mentions none of the investigators, nor their investigations. Instead it lays into the "News of the World" with ridicule and accusations of gross exaggeration, hyping up a non-event to sell papers. In the end it specifically states that the case is "fiction."

## LIES

Under Britain's libel laws this is certainly a candidate for a lawsuit. Brenda, Dot and I supplied the data to the "News of the World" (under contract) and so the accusation of that material being fiction falls on us as much as the paper. To win damages all we would need to do is prove that the evidence is not fictional. We would not even need to prove the reality of UFOs. Naturally, we would relish the opportunity.

Sadly, to fight the case would take thousands of dollars, which none of us have. Despite rumours to the contrary circulating around the USA, Brenda, Dot and I are penniless thanks to this case. We are not millionaires. We have had costs way in excess of the small sum paid to us for the book, or from the newspaper. Dot's telephone was disconnected because she could not

pay her bills. I have had to sell my house. Brenda has more or less had to retire from ufology.

The "News of the World" lawyers passed judgement that the *Lies!* book was actionable, but the paper's sponsors backed out of the court case with no reason given. So it looks as if the get-UFOs campaign will score another victory.

Ian Ridpath's January 1985 article was in "The Guardian" (the only highbrow newspaper, a favourite of government officials, not yet to carry the whitewash). It mentioned neither the book nor our investigations, failed to reply to any of the criticisms of the lighthouse theory we have previously set out for its writer, and stated that he had solved the case and everything else was the product of the imagination of "UFO buffs" and the U.S. Air Force.

On 5 March 1985, I was asked to take part in a TV debate networked across the country by the I.B.A. (the independent equivalent of the BBC). The discussion was on UFOs in general, but I was promised that Rendlesham Forest would get an airing. My opponent was Dr. John Mason, an astronomer with whom I have cordial relations despite his semi-skeptical stance. However, Ian Ridpath contacted the IBA and invited himself into the audience. From the floor he hogged a lot of air-time to tell everybody he had solved the case. I was not asked to reply and was eventually forced to

interrupt and shout out one, pungent and decisive remark.

"Let us kick this lighthouse nonsense in the head right away," I said. "It was not a lighthouse which flew over someone's house outside the forest!"

A large section of the audience applauded this and afterwards wanted to know why so much air time was given the anti-UFO speakers.

Also in the audience was Ralph Noyes, whom we mention but briefly in *SKY CRASH*.

Noyes was head of the Ministry of Defense department DS 8 (which handles UFO matters) in the years 1969-1972. Now retired, but still covered by the Official Secrets Act, he surfaced in somewhat odd circumstances around the time of the October 1983 public pronouncements. I am still not sure why he has been able and willing to speak so openly about government UFO policy and the Rendlesham case in particular. We speculate in the book that a move is afoot to slowly "leak" the truth to the public about the UFO conspiracy. If that is so the sudden high profile of such a man is understandable. If it is not so, then we have to ask what other reason there is for his remarkable bravery.

## DISINFORMATION

In January and February 1985,

(continued next page)

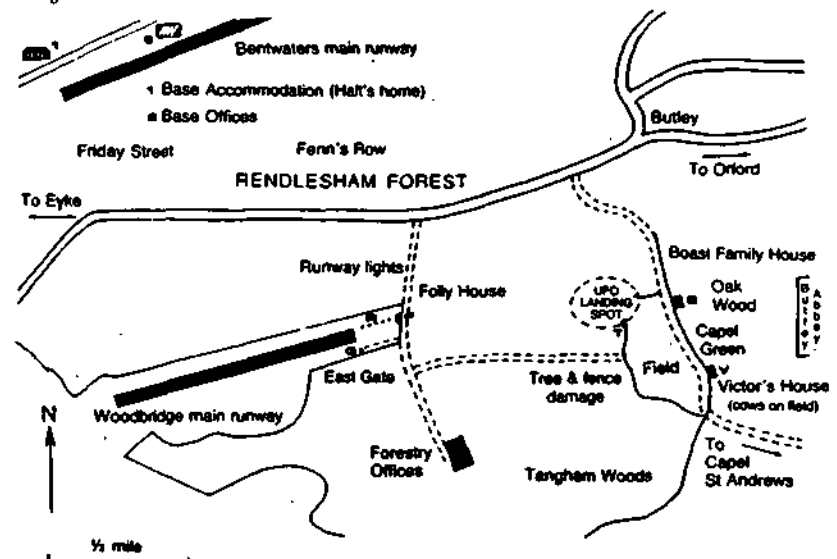

General area of encounter

## RENDELESHAM, Continued

Clive Ponting, a man on the same civil service ranking as Ralph Noyes, found himself prosecuted under the Official Secrets Act by the British government. This was for leaking a letter on the sinking of the Argentine warship the "Belgrano" during the Falklands War of 1982. The leak was to a parliamentary member, not the public, at a time when that man was heading a commission of all parties officially charged with the investigation of the sinking. Ponting believed it right that this commission should see the document, demonstrating attempts to disinform the House of Commons about the incident.

Ponting was head of Ministry of Defense department DS 5 (the exact equivalent of the one Ralph Noyes headed — dealing with naval matters as opposed to aerial ones). The repercussions on Ponting make the actions of Ralph Noyes all the more extraordinary, unless he knows he is acting without fear of consequence.

In many discussions I have now had with him he has frankly admitted that a "situation map" exists logging all unexplained sightings for Ministry of Defense staff. He has told me of gun-camera film taken by RAF pilots held under lock and key. And he has stated baldly that the Ministry of Defense have "lied and covered-up" the Rendlesham Forest case.

Several of these things Noyes has said on radio and TV interviews he has been willing to give (especially to Nippon TV in Japan and Cable News Network in the US). He attended the press conference at the launch of *SKY CRASH* (although his preannounced presence still attracted no British media source). On the March 1985 TV programme he backed me all the way and said, in front of live cameras and millions of viewers, that he had no doubt that the Ministry of Defense knew far more than they were telling about UFOs, and they had very good reason for obscuring the truth.

Ralph Noyes is scathing of the lighthouse explanation, and (copies sent to me) has often pressed the British government hard on the matter. He has also sent me copies of the replies he has received, but so far he

has no more than the evasions we have been subjected to for years. "I can assure you that there is no evidence of anything having intruded into British airspace and 'landing' near RAF Woodbridge" is the best the current DS 8 chief has had to say to him.

But what does this ambiguous reply mean? The Ministry of Defense love putting words into inverted commas, as we explain in *SKY CRASH*. Does "landing" mean that something *did* intrude but it "crashed?" Does the word intrude mean it was there with knowledge and/or invited in? Or does it all mean it was one of our own craft? Each option remains viable in the face of what, to the casual observer, looks like a specific denial by the Ministry of Defense.

Fortunately, Ralph Noyes knows all about how the governments of the world are gifted wordsmiths. He explained to me that it is paramount that you never tell a lie, unless you absolutely have to. The same effect can usually be achieved by wording your reply in such a way that it reads like a dismissal but will legally hold up as an acknowledgement if the issue is ever forced. Now we know why it often takes weeks or months to get answers out of government bodies. They spend hours poring over the precise wording to have

the maximum effect.

In June 1985, Ralph Noyes publishes his "UFO Novel," which is set in Rendlesham Forest in 1990! It involves a USAF base known as "Bentbridge," but in his "factual afterword," which Ralph has shown me, he discusses the *SKY CRASH* research briefly and adds that the case in his book is definitely *not* based upon it!

I am sure we all await with interest what his book *A SECRET PROPERTY* (to be published by Quartet Books) has to say. Will it be another step on the road to revelation? Is it the next lesson in the education programme for mankind? I wonder.

The future certainly promises to be far from dull.

*Editor's note: The demand for SKY CRASH in the United States has far exceeded supplies available to book dealers, creating "waiting lists." It is conceivable that Neville Spearman made the same mistake as Prentice-Hall when they published insufficient quantities as in the case of CLEAR INTENT (CLEAR INTENT is now in its sixth printing).*

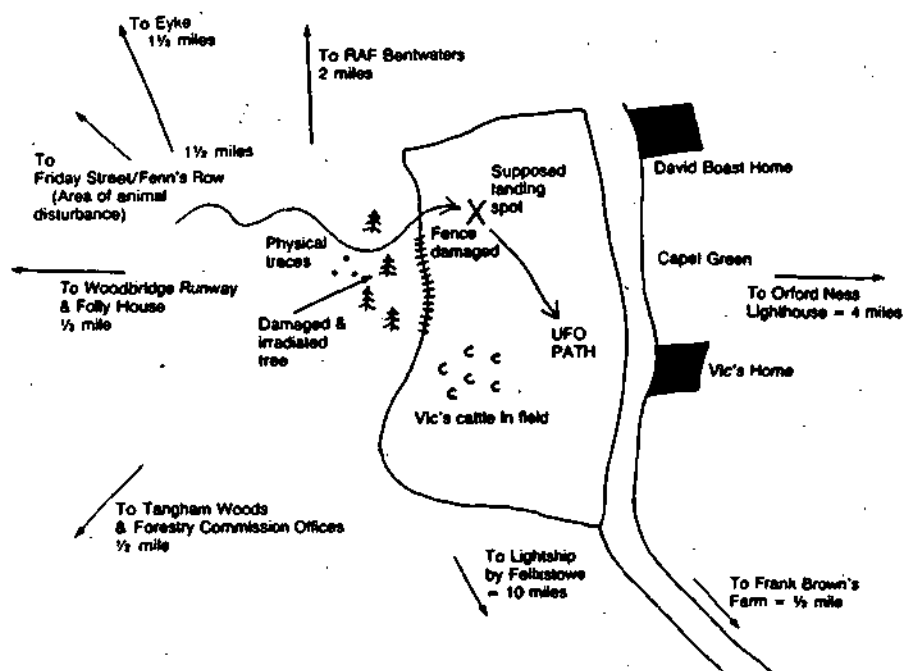

Close-up details of landing site.

# KIRTLAND LANDING

-by Bruce Maccabee

The morning of August 9, 1980, was only about 20 minutes old when a security guard spotted a "round disc shaped object" with a very bright light which had landed in a restricted test area east of Kirtland Air Force Base, Albuquerque, New Mexico. Subsequently the object ascended rapidly into the air. Both the landing and the ascension were witnessed by a group of guards about five miles away at the time.

A report of the landing, prepared by agent Richard Doty of the Air Force Office of Special Investigations (AFOSI) at Kirtland, became public in the spring of 1983, apparently as a result of a "leak" which was followed by a Freedom of Information and Privacy Act (FOIPA) request by a UFO investigator (Barry Greenwood).

In the spring of 1984, I contacted Doty to find out if he had more information than was contained in the 1½ pages which had been released. I was not surprised to hear him tell me that he had interviewed the witnesses, gone to the landing site, and had written a larger report. I was not surprised

because I found it difficult to believe that the Air Force would overlook something as important as a landing of SOMETHING inside a restricted (nuclear) storage area. He also said that there was more that he couldn't tell me. He further suggested that I write to Headquarters (HQ/AFOSI) to obtain all releasable information.

I therefore wrote to HQ/AFOSI and requested the follow-on document under the FOIPA. The Chief of the Information Release Division, Noah Lawrence, denied that there was another document because there was none on file at HQ/AFOSI. Subsequently, because of my insistence, he called Doty on the phone and Doty (evidently) told him there was no such document. I then had a long conversation with Lawrence and he admitted that there was a "discrepancy" between what Doty told me and what he told Lawrence. Lawrence then requested that Doty be interviewed by his commanding officer (Lawrence did not interview Doty himself). The commanding officer (evidently) reported back to Lawrence

that Doty denied the existence of another document. According to Lawrence, without a specific name or a file location of this report continued requests are futile.

Unbeknownst to me, author/investigator Bill Moore had independently researched the case in 1982. After I had completed my investigation I told him what I had learned and he informed me of his investigation. The results of his investigation, which are included in a summary written by Moore, agree with my results, adding further evidence to my suspicion of a cover-up.

This report summarizes what is now known about the incident and my attempts to find a doorway into the "Cosmic Watergate" which prevents the public from knowing the truth about the involvement of military intelligence agencies with the UFO problem.

The full report is available from:  
Fund For UFO Research  
P.O. Box 277  
Mt. Rainier, MD 20712

## Support National UFO Week

18-25 Aug., 1985

Inform Yourself-Inform Others!

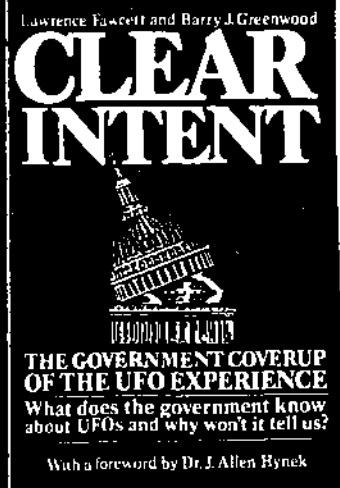



## *BLACK HOLE OVERTURE*

by

*Bruce Maccabee*

The French Army under Napoleon had just invaded Russia when I first saw it...a tiny black spot against the bright blue sky.

The invasion, as portrayed musically by Tschaiikowsy in the 1812 Overture, was proceeding smoothly, with cannon firing. I was admiring the clear evening sky and just randomly looking around at the crowd of people standing near the band shell in the Inner Harbor in Baltimore (see map). Directly east of me was the wooden battleship *Constellation* with its three high masts.

The top of the highest mast was about 170 ft. above my altitude. South southeast of me was a modern steel battleship with radar and other antennas above its highest deck. It was while casually glancing at this ship that I first noticed the "black hole".

### TIME

I couldn't identify it immediately when I first saw it, but I wasn't impressed. I could see a number of dark "spots" ...birds.. moving around in the sky. I assumed that his particular "spot"

would resolve itself into something recognizable and returned my gaze to the scene in front of me. But, as my eyes wandered back and forth over the Inner Harbor area of Baltimore, I again looked southeastward. By comparing the direction to the black spot with the direction to the superstructure on the steel ship, I could see that the spot was moving steadily toward my left (northward).

I was surprised that I still couldn't see it well enough to identify it, so I started to watch it intently. After

watching the "spot" for about ten seconds I decided that it was sufficiently odd that I would make a note of what time I first saw it. (I have trained myself to do this whenever I decide that something in the sky looks unusual, just in case....) Looking at my digital watch I saw that it read 7:28. (Subsequently I found that my watch was 1.5 minutes fast. Note: I made no note of the seconds, so estimates of elapsed time are only accurate to within about one-half a minute.) I returned my attention to the Baltimore Youth Orchestra directly east of me.

Fifteen or so seconds later I looked back toward the steel battleship. The direction to the "black hole" had changed considerably. It had moved farther northward and was higher in the sky than before. It also appeared larger in angular size. I was disturbed by the fact that I couldn't see any details of the object other than its outline against the sky. I had the impression that the shape of the outline was changing continuously as it moved northward. I pointed it out to my wife, Christine, and then looked around at the crowd of people nearby. Several people near me definitely appeared to be looking in the direction of the black object. Were they, too, looking at it? I began to watch it intently.

### WHAT IS IT?

What is it, I kept asking myself. I could imagine trying to describe it to someone: "Well, it had no shape...it was amorphous."

But that wouldn't have been correct, of course because it did have a specific outline against the sky at any instant in time. However, the outline was continually changing as it moved. There appeared to be a slight wave, like an ocean wave, moving in a counterclockwise direction around the edge as it traveled along. I thought of a wheel "rolling" through the sky, although there were no spokes or hub. I had the feeling that it would eventually rotate into such an orientation that I could see wings or something that would identify it. It appeared to go through a cycle of shape change. For a period of time estimated at 5 - 10 seconds the outline was quite round and it changed very slightly. Then over

the next 10-15 seconds the outline became more elliptical or cigar shaped and finally over the last 10-15 seconds of the "cycle" the ellipticity decreased and the outline became generally round again.

During each cycle as the outline became more elliptical I had the impression that it would become "airplane-shaped" (as an airplane seen broadside from below). I concentrated on trying to see the wings. Yet, the only actual evidence of a wing that I could see was a short protrusion that appeared at the top of the object when the outline was elliptical or cigar-shaped. If an observer on the ground saw an airplane flying past (i.e., viewed broadside from below) at an elevation angle of, say 40 degrees, the closer of the two wings would appear, in silhouette, to be above the main body of the plane and the farther wing would appear to be below the main body. I concentrated on the bottom of the outline of the object looking for the "lower" wing, but my efforts were in vain. I simply could not see the other "wing." Nor could I see any "tailfin" such as would appear at the rear end of a plane. I could not even see any part of the object moving in front of or in back of any other part. In fact, there didn't seem to be any three dimensionality. From what I could see the object could have been two-dimensional...a flat black object with an outline that changed as it traveled through the sky.

### FLAT BLACK

I was also puzzled at the lack of brightness highlights within the outline of the object. It seemed to me that it was high enough to be illuminated by the setting sun, and yet there appeared to be no surface reflections. It was as if some oddly structured three-dimensional object had been painted with flat black paint so that it would not reflect any light and then the object continually rotated in a complex way while traveling through the sky.

Although I kept a close watch on this object over the next minute or so, I repeatedly cast my gaze elsewhere for short periods of time (seconds) in order to compare it with other things in the sky. There were numerous birds flying around at various distances. I had no

trouble identifying them, even when they were so far away that their bodies were mere dots against the sky.

I also saw a commercial jet that was about to land at Baltimore-Washington Airport. It was about 5 miles south of me at angular elevation of about 5-10 degrees. Although all I could make out at the time I looked was the fuselage, I could see gradations of brightness of the curved greyish metallic surface as it reflected the skylight and the light of the setting sun. I could also see gradations of brightness on the bodies and wings of the birds. Gradations of brightness are a characteristic of a three dimensional object. Yet, try as I might....and believe me, I tried....I could not see any gradations of brightness associated with the black spot. It seemed to be totally black. It was as if I was looking at a "hole" in the sky....a black hole into which all the illuminating light had "fallen" and none was coming back out.

### NO KITE

About a minute after I first saw the object the sighting line to the object was almost over the *Constellation*. I asked my wife what she thought. She suggested that it was about the size of a kite, perhaps a box kite. I did not buy this, however. No kite would travel the angular distance this object had traveled without rising up into the sky. Furthermore, it did not have the right shape or outline for either an ordinary flat kite or for a box kite.

I decided that things were getting serious. I knew that I had binoculars in the back of our station wagon which was about half a mile away in a parking lot. Should I run and get them? I would have to make a mad dash through the crowd to get them, and would it be worth it?

As I watched the object and thought about the binoculars it continued to move steadily northward. The angular elevation and the angular size both increased and now my line of sight passed directly over the masts of the *Constellation*. I decided that if I only waited and watched carefully the object would "give itself away." I concentrated on the object, looking for

(continued on next page)

## OVERTURE, Continued

the slightest evidence of surface reflection. I kept thinking that the moment of identification was at hand.

But it wasn't. The object reached its highest angle of elevation when it was in the direction of the *Constellation* almost due east of me. Apparently that was the point of closest approach because then the elevation began to decrease while it was still traveling northward at an essentially steady rate. When it was at its closest I had stuck up my arm to compare the angular size of the object with the angular size of my little finger. It was much smaller than my finger, but it did have apparent size. By subsequent measurement (after the sighting) I concluded that the maximum angular size was in the range 1/2 to 1 mm. at arms length (about 50 cm), corresponding to an angular size of 1 to 2 milliradians (e.g., 1 to 2 feet at a distance of 1000 feet). As the object continued to move northward the angular size shrank and the angle of elevation decreased. I was still debating whether or not to run for the binoculars when my view of the object was cut off by the southern corner of the World Trade Center (see map). The elevation of the sighting line was a few floors below the top of the building which I found later to be about 405 ft. high and about 720 ft. from where I stood. Thus the elevation at this time was about 26 degrees.

I looked at my watch. It read 7:30. In about two minutes this black object had traveled an angular distance which I estimated at the time to be about 60 degrees (actually it was about 70 degrees). I estimated that the Trade Center building was only about 10 degrees wide, so I expected the object to appear on the other side in a relatively short time, certainly no more than half a minute.

I returned my attention to the orchestra playing right in front of me. I would glance to the left (north) of the Trade Center building every ten or fifteen seconds, expecting to see the object appear again. But it hadn't appeared after about thirty seconds. So I waited some more. The Russian-French battle was really heating up...and I was getting nervous, still

waiting for the reappearance.

## DISAPPEARS

I began to worry. I looked at my watch. It read 7:31, and still no object. Could it have disappeared? Finally it reappeared, considerably smaller in angular size than before. My watch read 7:32. It had taken about a minute and a half to two minutes to change its azimuth by only about 10 degrees, whereas in the previous two minutes (7:28-7:30) it had changed its azimuth by about 60 degrees. Why did it take so long? I decided that it must have changed direction while it was hidden from me and was now heading more eastward. I continued to watch carefully. The direction to the object still moved northward, but very slowly now. In fact, during the last couple of minutes that I could see it, it seemed to maintain a constant azimuth (see map) and a nearly constant elevation. I watched as it shrank to a tiny dot and eventually I could no longer see it against the sky. My watch read 7:35.

During the last couple of minutes the object was evidently traveling directly away from me toward the east northeast, since the azimuth didn't change noticeably. It did not seem to be traveling with the (surface) wind, which was from the south southeast, as indicated by the numerous flags that were in the area.

Furthermore, since it appeared to maintain a nearly constant elevation angle during the last couple of minutes, its actual elevation must have increased slightly to compensate for the increased distance.

As the object shrank to a barely visible dot I compared it to a distant bird. The bird was so far away that its body appeared as an unresolved black dot against the sky. But I knew it was a bird because I could see the effect of the wings flapping. At its closest the angular size of the object had been much greater than the angular size of this bird. So why hadn't I been able to see any details of the object? I wished I had run for my binoculars. In thinking about the sighting afterward I realized that there was a second reason for running for the binoculars: I would have changed my position on the ground enough to give myself a baseline for a

crude estimate of the altitude of the object.

After the concert was over Christine and I left the Inner Harbor and drove to her parents' house in a suburb of Baltimore. While there I wrote down what I could remember of the sighting, made sketches of the object, asked Christine to do the same, and called a radio station (WBAL) to find out if they had had any other reports. They didn't have any reports, but I wasn't surprised. The "black hole" didn't do anything spectacular. It just traveled at an apparently constant rate over the Inner Harbor. It made no noise, so far as I could tell, that would attract attention to it. I expect that people who did notice it thought it was peculiar, but then ignored it.

Had it been a silvery disc glinting in the sunset as it traveled along I'm sure it would have been reported by hundreds of people. But this object was just not "flashy." Its major peculiarity was its blackness. It was of such a small angular size (at least from my location) that it posed no apparent threat to anyone. It just shouldn't have been there...or anywhere, but probably most of the witnesses didn't realize that.

The following report is based on my notes made 1.5 hours after the event and upon supplementary experiments that were done to estimate my visual acuity.

©1985 Bruce Maccabee  
Bruce Maccabee's report will continue  
in the next issue of the Journal - Ed.

— MUFON —

AMATEUR  
RADIO  
NET

—

EVERY SATURDAY  
MORNING  
AT 0800 EST (OR DST)  
ON 7237 KHZ S.S.B.

# SOUTH AMERICAN "UFORIA"

-by James Oberg

Argentina and neighboring South American countries continue to suffer "UFO panics" set off by the overflights of Soviet rockets. Some of the most spectacular and widely witnessed UFO apparitions in South America have been caused by entirely prosaic (if genuinely extraterrestrial!) space flight events. The flying saucer fantasy would seem to be what the newspapers (and most of the public) seem most interested in, so recent attempts to communicate the true causes of such sightings have not met with much success.

The latest such events occurred on the evening of March 16 and July 3 of 1984. Press reports spoke of "plativilo (flying saucer)" visitations over a dozen provinces of Argentina, as well as areas in Chile, Uruguay, Paraguay, and southern Brazil. But the UFOs were actually as tenuous as a cloud of gas in outer space - which is exactly what they were.

## SOVIET SATELLITES

Many Soviet satellites launched from the Plesetsk space center (north of Moscow) are often bound for a special elongated 12-hour orbit with its high point over the northern hemisphere. To get there, the vehicles must first go into a low parking orbit and then, an hour after launching, they fire a fourth stage rocket to push the payload onto its final orbit. Because of geographic factors, these rocket firings take place over the southeastern Pacific Ocean, just off the coast of southern Chile, as the satellite is orbiting in a northeastwards direction. After the firing, the rocket expels excess fuel which briefly creates a gas cloud several tens of kilometers across. Such orbits range from 600 to 40,000 kilometers in altitude, and have inclinations to the equator of about 63 degrees. Two main types of satellites use such orbits: "Molniya" communications satellites (most of

which are launched from Plesetsk, with a few launched from Tyuratam in Central Asia), and "Missile Early Warning (MEW)" payloads which are labeled as part of the catch-all "Kosmos" satellite program. There are nine active MEW-Kosmos satellites orbiting one after the other in a formation called a "constellation"; Molniya satellites are arranged in two constellations, designated "Molniya-1" (eight payloads) and "Molniya-3" (four payloads).

## AVERAGE LAUNCH

On the average, such launchings take place about once a month, to replace on-station satellites which break down or exhaust their maneuvering fuel supplies. The shots occur randomly throughout the 24-hour day. If the overflight happens to take place soon after sunset in southern South America, the orbiting gas cloud (and space vehicle, plus booster, plus fragments of protective covers) is lit by the recently set sun while the sky is dark for observers on the ground.

The resulting apparition, a cloud-like circular mass with a darker center, is several times the size of the moon, flying about 20 degrees above the western horizon; it crosses the sky in only a few minutes. Sometimes small pinpoints of light accompany the cloud; occasionally, the actual rocket firing will be visible as a yellow "V" pointed northwards.

1978	Aug	22	at	10pm
1980	Feb	11	at	9pm
1980	Jun	14		
1981	Oct	31		
1982	Mar	23	at	10pm
1982	May	28	at	8pm
1983	Aug	30	at	9pm
1984	Mar	16	at	10pm
1984	Jul	03	at	8pm

## TWILIGHT ZONE

Of the more than 150 such launchings since 1970, about a dozen fit into this "twilight zone" of visibility in the early evening (there is no corresponding morning visibility because the cloud is so far down in the western sky). In the past six years alone, there have been nine launchings which happen to fall into this category, and every one of them set off spectacular "UFO encounters" (See table.)

All kinds of traditional UFO perceptions were sparked by these apparitions. Eyewitnesses described bizarre motion (including turns, stops and starts, chases, rising from the sea, "nearly landing", rapid recession), electromagnetic effects (radar blips, television and other electrical appliance failures), psychological effects (drowsiness, fear, "time lapses", telepathic messages); there was even at least one Close Encounter of the Third Kind, when a witness claimed an alien creature from the UFO (actually, Kosmos-1317) visited him and talked with him.

There was one difference from more "traditional" UFOs: the plethora of photographs by independent witnesses. Many of the apparitions were extensively photographed from points hundreds of miles apart, providing indisputable evidence that

(continued next page)

(Molniya 1-42)
(Kosmos - 1164 MEW)
(Kosmos - 1188 MEW)
(Kosmos - 1317 MEW)
(Molniya 3-18)
(Molniya 1-54)
(Molniya 3-21)
(Molniya 1-60)
(Kosmos - 1581 MEW)

## Soviet Satellite Launch Dates

**"UFORIA", Continued**

"something" was up in the sky. Such high-quality, multi-witness photographic evidence is notably absent from "real" UFO encounters.

**PSEUDO-UFOS**

The connection between such pseudo-UFOS and Russian space shots was discovered and documented by myself, as part of the investigation of the spectacular June 14, 1980, apparition. That case had been written up as a genuine UFO in a late 1980 issue of *The International UFO Reporter*, published by Dr. J. Allen Hynek's Center for UFO Studies in Evanston, Illinois (which has yet to publish the solution). The conclusions of my own research were written up for an article in *FATE* magazine, which subsequently formed a chapter in my book on space age folklore, *The Great Galactic Ghoul and Other Space Legends*, scheduled for publication this year.

Several South American ufologists cooperated on the research and did

extensive work to uncover many of the cases. They include Dr. Wily Smith of CUFOS, Antonio Huneus, and Alejandro Chionetti. Their research is continuing and new insights can be expected. They have eagerly accepted the actual cause of the cases and are enthusiastically seeking additional eyewitness reports.

In the future, more such pseudo-UFOS can be expected to be seen on a regular basis. Obtaining tracking data which is needed to determine the exact launch time of such vehicles is difficult. As a rule of thumb, however, whenever such cloud-like UFOS are reported moving south to north in the western sky of Chile and Argentina soon after sunset, and TASS news agency in Moscow later announces the launch of a satellite with the tell-tale orbital parameters, it will be entirely reasonable to associate the two events and, as a first approximation, consider the case "solved".

**PERIPHERAL DETAILS**

Yet what about the testimony of

strange motion, radio interference, and so forth, which cannot be explained by a sunlit fuel cloud? Dr. Donald Menzel, a leading astronomer and UFO skeptic of the 1950s, had a recipe for processing such "data": "Throw it in the wastebasket," he snorted. That may be too harsh, since the South American experience has shown that UFO reports are indeed worth examining closely, precisely because they may not be caused by "true UFOS". But it is an accurate assessment of the reliability of such descriptions.

Indeed the very existence of such testimony, caused by a prosaic stimulus, is a powerful skeptical argument that the existence of similar testimony elsewhere does not prove the need for some sort of truly extraordinary stimulus - there need not be any "true UFOS" out there to cause all kinds of "UFO reports".

Meanwhile, for the South American public and its OVNImania, or "uforia", the topic is so popular and exciting that the truth may never catch up.

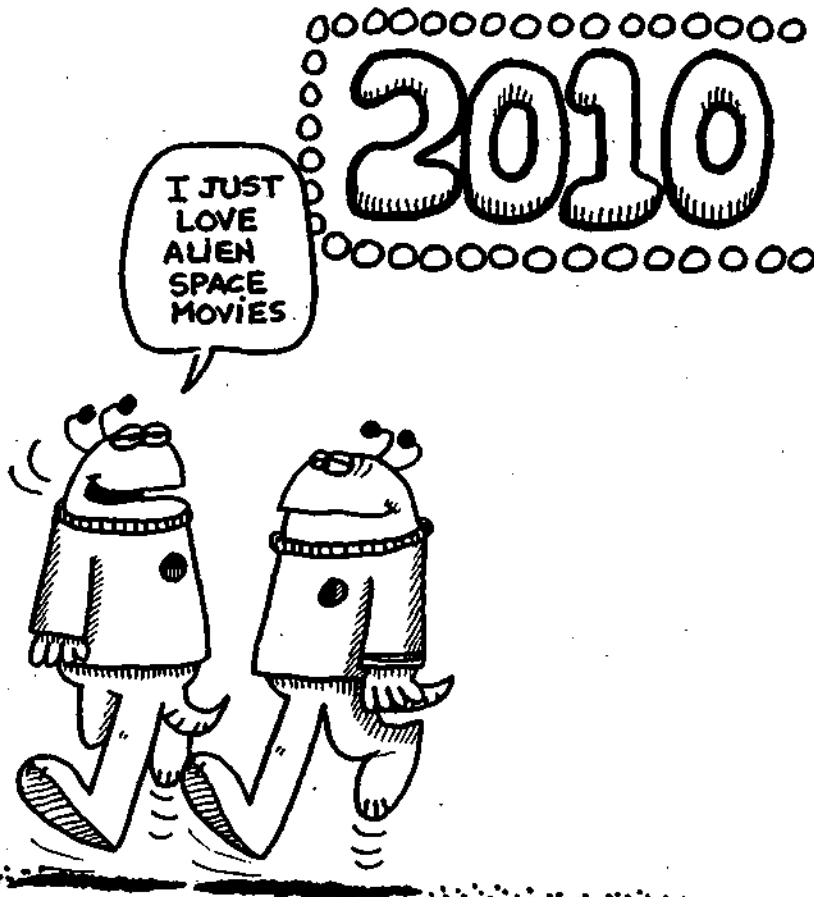

LEO

**Support**

**National**

**UFO**

**Week**

---

**18-25 August**

**1985**

---

**Inform Yourself-**

**Inform Others!**

# CURRENT ITALIAN SCENE

-by Edoardo Russo

1984 was not such a quiet year for Italian ufology. As for UFO reports, it was not rich, but media coverage and research activities did show a consistent increase.

## UFO/IFO REPORTS

Eighty-five (85) sightings have been filed by Centro Ufologico Nazionale as of January 25, 1985. There were 269 in 1980, 80 in 1981, 24 in 1982, and 212 in 1983. Most of the 1984 reports were NL in type. The only cases really interesting are two CE-II/III which incidentally took place a few hours from each other on October 9th.

At 3:30 a.m., a housekeeper in Polcanto, near Florence, was awakened by a light coming from the window, and saw for some instant a dark human shape upon a nearby hill, from whose forehead a torch-like beam was coming. It disappeared and a dark horizontal line remained visible under which three flames descended towards the ground. After some minutes, it disappeared suddenly and a great blinding white light began approaching, illuminating all the area like daylight.

The witness tried to get to the window but was partially paralyzed before arriving. It looked like the light was sucked back. A red sphere appeared then, the intermittent light of which harmed his eyes; they remained red and irritated for some days. Three circular holes, 10 cms. in diameter, 3 cms. in depth, in a 2 mt. irregular triangle, were found in the area, where the grass looked pressed. No radioactivity was recorded. The dog, sleeping outside, did not bark and showed unusual behavior, refusing food for some days, remaining inside his bed for the next two weeks without barking at strangers. The most complete investigation report on this event is by Pier Luigi Sani.

At 7:30 a.m. on the same day, a peasant in Prata Principato, near Avellino, watched a 1.30 mt. tall man in

a brown "space-suit" with a helmet connected to a rucksack by two pipes, holding a forked stick in his hand, and hovering above the ground emitting blue sparks to a "space-craft" which took off at once. Six conical holes in a rectangle, plus two large traces and some footsteps were found in place by C.U.N. investigator Umberto Talarico. Traces remained hotter than the environment for two days and intrigued Carabinieri investigators.

## FEBRUARY FLAP

Local flaps were recorded in the Northeastern provinces of Veneto, Friuli and Trentino in February, when hovering lights were seen and heard "humming" by many. These same areas and Northwestern Italy (Piemonte, Liguria) were repeatedly overflowed by glowing lights with long trails in early December.

On December 5, at 11:30 a.m. in full daylight, hundreds of people in the provinces of Cuneo, Imperia, Savona and Genova noticed a very bright

oblong shape arriving from France followed by a luminous trail, and exploding with such a flash that people inside houses ran out. A loud series of "booms" was heard by tens of thousands of inhabitants all over the region and even recorded by the seismographic network. A dark cloud remained in place for more than half an hour.

## RESEARCH CONTINUES

Three on-going projects producing results in 1984 have been:

1. Regional Catalogues of reports, developed by local investigators, which resulted in a complete filing (and publication of a Catalogue) of Italian 1980-1984 UFO/IFO sightings in an "open" Data Bank, operated by Gian Paolo Grassino in Turin.
2. "Project Italy 3", about Italian CE-III's: a complete list of all reports and sources on such cases was completed by Paolo Fiorino.

(continued next page)

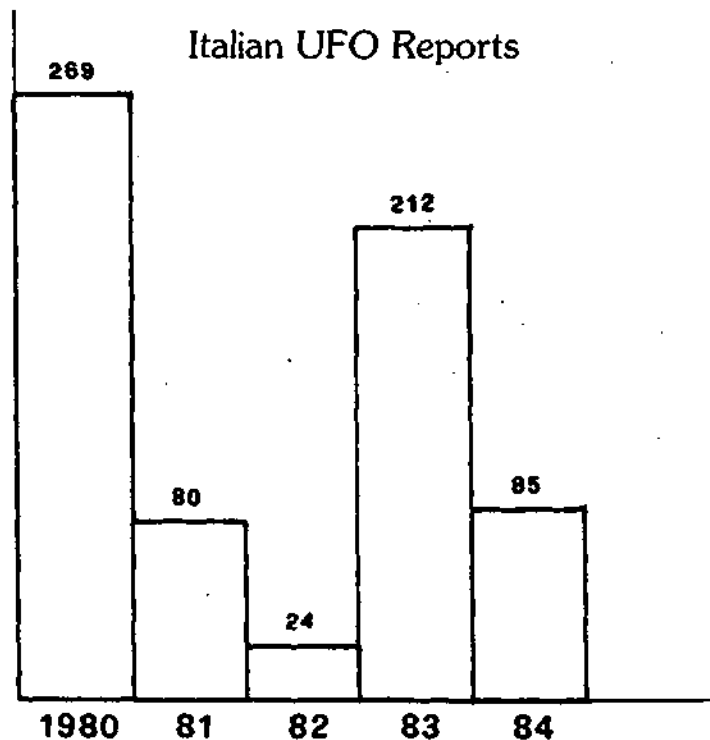

## ITALIAN SCENE, Continued

3. "TRACAT": Maurizio Verga's reference-list of Italian trace-landing cases was largely updated in 1984 and presently contains summaries of 153 reports.

Two new research projects were launched by C.U.N. in 1984:

1. "Project Origins": a full-scale survey of library collections of old newspapers of the 'early years (1946, 1947, 1950),' in order to collect all relevant data on the birth of the 'UFO saga' in Italy; greater press coverage than expected was found in that period.

2. "Project 64": a micro-computer network (mainly consisting of Commodore 64s and Apple IIs) with the aim of completing a full indexing of all Italian case reports by the end of 1985. More than 4,000 entries have already been catalogued.



*Artist's conception of  
Air Force photographs.*

### PUBLICATIONS

UFO journals have had some troubles in George Orwell's year: only one issue was published of each of the following: *NOTIZIARIO UFO* (C.U.N. bimonthly), *UFOLOGIA* (a special issue on the French new ufology), and *DOCUMENTI UFO MONOGRAFIE* (on hypnosis and ufology).

In December the long awaited C.U.N. Field Investigators' Manual was published.

Two UFO books were published: the Italian translation of Jacques

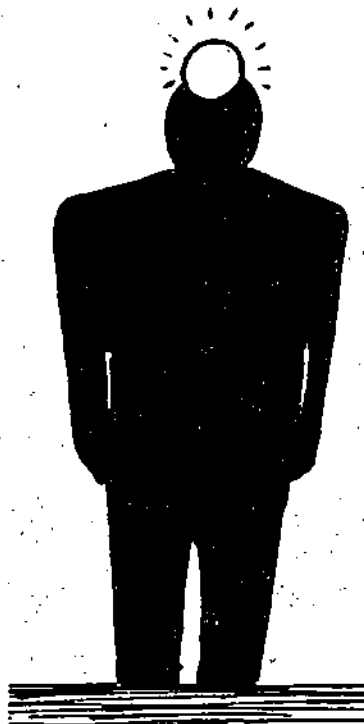

### Polcanto entity.

Vallee's *Messengers of Deception* and the case history of the abduction series of night-watchman F. Zanfretta, by journalist Rino Di Stefano (title: *Lights in the Night*. Well known Italian writer Peter Kolosimo suddenly dies in March.

### MASS MEDIA

In 1984, C.U.N. collected 450 newspaper clippings about UFOs in Italian newspapers, with a marked increase over the 1981-1983 average. Some events particularly evoked press interest and coverage: C.U.N. Congresses in Palermo (January) and Genova (May) and mostly the official request by four Congressmen to the Government (under guidance by C.U.N.) that the Ministry of Defense open its files to private researchers.

The Minister answered that UFO files are actually unclassified and contain no really unidentified reports. C.U.N. Vice-President and foremost Italian field investigator, Antonio Chiumiento, asked the Ministry for details about a UFO-pilot encounter with photographic evidence in 1979, and the Ministry answered that it was just a balloon made of black plastic bags, but released none of the 80 shots. Newspapers, radio and TV devoted ample space to the matter in the second

half of the year.

Further details on the above reports, research and events are reported in C.U.N. "1984 Annual Report" (in English), available from: C.U.N., Corso Vittorio E. 108, 10121 Torino, Italy.



*Cartoonist's view of the  
Italian Minister of Defense*

### UFO NEWSCLIPPING SERVICE

The UFO NEWSCLIPPING SERVICE will keep you informed of all the latest United States and World-Wide UFO activity, as it happens! Our service was started in 1969, at which time we contracted with a reputable international newspaper-clipping bureau to obtain for us, those hard to find UFO reports (i.e., little known photographic cases, close encounter and landing reports, occupant cases) and all other UFO reports, many of which are carried only in small town or foreign newspapers.

"Our UFO Newsclipping Service issues are 20-page monthly reports, reproduced by photo-offset, containing the latest United States and Canadian UFO newsclippings, with our foreign section carrying the latest British, Australian, New Zealand and other foreign press reports. Also included is a 3-5 page section of "Fortean" clippings (i.e. Bigfoot and other "monster" reports). Let us keep you informed of the latest happenings in the UFO and Fortean fields."

For subscription information and sample pages from our service, write today to:

UFO NEWSCLIPPING SERVICE  
Route 1 — Box 220  
Plumerville, Arkansas 72127

## NEWS'N'NOTES

-Dennis Stacy, Walt Andrus

President Reagan's announcement that the United States would unilaterally continue its defensive space weapons program known as "Star Wars" was one thing, but now the Soviets have to contend with another Space Invader — Unidentified Flying Objects.

Reports of sporadic UFO sightings in the Soviet Union and allied eastern bloc nations have periodically percolated through the Iron Curtain. Such reports have usually been greeted with caution by western skeptics like James Oberg of NASA, a member of the Scientific Committee of Investigations of Claims of the Paranormal (SCICOP). Oberg, author of *Red Star in Orbit*, a study of the propaganda peccadilloes of the Russian space program, has maintained in the past that Soviet UFO reports were manipulated as a sort of safety valve. They were officially discouraged on one hand, according to Oberg, and ostensibly allowed on the other in order to draw public attention away from highly visible rocket launches made at the USSR's supersecret northern Cosmodrome, Petrozavodsk.

### JELLYFISH COSMOS

One case in particular involved a "jellyfish-shaped UFO" seen over Petrozavodsk and widely reported in the Soviet and world press. "There's hardly a doubt in the mind of anyone who looks seriously at the data," says Oberg, "that that was a launch of Cosmos 955."

"If I had to speculate, I would say that the Soviet authorities look upon UFOs as a harmless, intellectual diversion. In other words, you can't be a political dissident, but you can be a UFO dissident and it doesn't hurt." More recent developments in the Soviet Union, however, may have their own citizens, like their counterparts here, wondering exactly what to believe

and what not to believe about UFOs. In May of last year, a union trade daily, *Trud*, announced that a commission had been established to investigate unidentified flying objects. At its head was former cosmonaut Pavel Popovich. The Commission on Abnormal Atmospheric Phenomena was supposedly formed in response to a "cigar"-shaped object reported over Gorky.

Interviewed by *Trud*, Popovich said the flying cigar was seen by air traffic controllers at the Gorky airport and picked up on radar. It was said to be about the size of an airliner, but without wings or tail. The object was about 3000 feet high and traveling at a speed of between 110 to 125 miles per hour. Reportedly, it failed to respond to attempts at radio contact. It was tracked by radar for some 40 minutes, passing north of Gorky and 250 miles east of Moscow.

The previous December, a bright sphere followed by several smaller lights had been spotted over Byelorussia and the central part of the country. Popovich said that after exhaustive analysis that UFO had definitely been explained as a satellite burning up on re-entry.

### STRANGE STAR

But in January of this year *Trud* was again reporting UFOs over the Soviet Union. Crew and passengers aboard an Aeroflot flight from the Georgian capital of Tbilisi to Tallinn in Estonia, supposedly saw "what appeared to be a large, unblinking star" pace their aircraft near Minsk. The "star," according to *Trud*, "suddenly shed a thin ray of light which fell plumb to the ground" from an altitude of 25 to 30 miles. "Ground control at the same time registered splashes on its screens in the same part of air space."

Co-pilot Gennady Lazurin, who relayed the sighting to Minsk, was at

first told that no ground radar control had been made. "Oh well, they'll be saying we're not normal," he was quoted as saying.

All four crew members said they "could see distinctly everything down in the sector of the ground illuminated by the cone-shaped shaft of light." At some point the ray was focused directly on the Aeroflot plane and "the pilots saw a dazzling white spot surrounded by concentric colored rings."

The UFO then dashed toward the airliner, leaving a green cloud in its wake. Next it took up position alongside the plane and accompanied it into Minsk "like an honorary escort," *Trud* said.

Nikolai Zheltukhin, corresponding member of the Soviet Academy of Sciences and the deputy chairman of a state commission on unexplained phenomena, said the sighting was "undoubtedly abnormal."

—DENNIS STACY

# MUFON

**AMATEUR RADIO NET**  
**EVERY SATURDAY MORNING**  
**AT 0800 EST (OR DST)**  
**ON 7237 KHz SSB**

MESSAGE, Continued

"Is there a Key to the UFO Mystery in the Jungle of Amazon?"; and Adolph Schneider, "Analysis of Reports about mini-UFOs from all over the World."



## SPEAKERS

The UFO Study Group of Greater St. Louis, host for the MUFON 1985 UFO Symposium at the Chase Hotel in St. Louis on June 28, 29, and 30, 1985 has announced the following specific plans for this year's event: The speakers and the titles of their papers are George D. Fawcett, "What We Have Learned from UFO Repetitions"; Budd Hopkins, "The Evidence Supporting UFO Abduction Reports"; William L. Moore, "Crashed Saucers: Evidence in Search of Proof"; Marge Christensen, "Shifting the Burden of Proof"; Leonard H. Stringfield, "The Fatal Encounter at Ft. Dix - McGuire: A Case Study" (Status Report IV); David F. Webb, "The Influence of Hypnosis in the Investigation of Abduction Cases." John F. Schuessler, Stanton T. Friedman, Peter A. Gersten, and Ted Phillips will also deliver talks. The speeches will address the theme for the symposium -- "UFO: The Burden of Proof."

Advanced reservations for all four sessions is \$25.00 prior to June 21,

1985. Checks should be made payable to "UFO Study Group of Greater St. Louis" and mailed to Mrs. Helen C. Hanke, 4024 90th Ave., Florissant, MO 63034. The price at the door for all sessions will be \$28.00. The price for each of the four sessions is \$7.50.

## SUNDAY BREAKFAST

An added feature of this year's symposium will be a "Breakfast With the Speakers" on Sunday morning. This will be an opportunity for everyone to talk with the speakers and be served a full-course, delicious breakfast by the Chase Hotel. The price of the breakfast will be \$10.00 and reservations are open until June 24, 1985. Hotel reservations can be made by contacting the Reservation Manager, Chase Hotel, 212 North Kingshighway, St. Louis, MO 63108. The phone number is (314) 361-2500.

Fifty rooms are being held for attendees, but reservations should be made no later than thirty (30) days prior to the Symposium to insure accommodations. Room rates are

\$60.00 per day for a single or double, \$70.00 for three persons and \$80.00 for four persons. There is no charge for children under 18 years of age.

On Friday evening, Ken McLean, State Director for Wyoming, will speak on public education to a special meeting being chaired by Mrs. Marge Christensen for State Directors, State Public Relations Directors and the members of MUFON's Public Information and Public Education Committee.

On Sunday morning, June 30th, the Annual MUFON Corporate Meeting will be held from 9 a.m. to noon. State Directors and Committee heads should be prepared to submit their written and oral activity reports. Election of officers will be conducted.

With the recent introduction of new ultra-saver rates by the major airlines to match the rates of other carriers, substantial savings may be obtained by making your reservations to St. Louis now in order to meet the specific conditions applicable to these new rates. "Meet Me In St. Louis."

—WALT ANDRUS



# STARS & PLANETS

By Walter N. Webb

MAY 1985

## DIRECTOR'S MESSAGE, Cont.

\*\*\*

Since computers are becoming an essential ingredient and a statistical tool to the resolution of the UFO phenomenon, we will be relating on a regular basis the current progress and utilization of these electronic marvels. The "bulletin board" UFO network financed by the Fund for UFO Research has been temporarily placed "on-hold." Bruce Maccabee has recommended COMPUFON to ufologists with computers. For this reason, we have referred our members to the newly established privately operated Compufon directed by Michael D. Hart, 803 - 5th Place S.E., Duvall, WA 98109, telephone (206) 788-5307).

Dale Goudie and Michael Hart have distributed their first public communication titled "The Compufon Network Newsletter" Volume I, Number 1, dated March 20, 1985 to the MUFON members who had expressed an interest in participating in the computer network; 33 members have assigned a personal I.D. Number for entry into the network and the password. Until the new I.B.M. equipment goes on-line about April 1, 1985, they are using their old Atari equipment at the home of Dale Goudie, in Seattle, Washington, telephone (206) 722-5738. Compufon is not a branch of any other UFO organization, but an entity in itself. They will cooperate with anyone interested in their services.

**Illobrand von Ludwiger**, the Coordinator of the Mutual UFO Network - Central European Section (MUFON-CES), recently reported on their annual MUFON-CES Conference in Osterburken near Heilbronn in West Germany on October 5, 6, and 7, 1984. The speakers and their subjects were Illobrand von Ludwiger, "How Scientifically is the UFO Researched?"; **K. Brauser**, "The Reliability of Human Perception"; **H.W. Peiniger**, "Reliability of size-estimates and statements about the duration of unexpected events"; **H. Markert**, "New Information about the Suffolk Case" (Rendlesham Forest); Illobrand,

(continued on page 17)

### Bright Planets (Evening Sky):

Mars, in Taurus, is dimly visible early in the month very low in the west after sunset. It fades into the twilight late in the month, setting only an hour after the sun.

Saturn, in Libra, reaches a point opposite the sun on the 15th, rising in the ESE at sunset and remaining in the sky until sunrise. The golden planet shines at zero magnitude, unusually bright because its flat rings are opened wide, thus reflecting more light, and also the giant world is closest to earth now.

### Bright Planets (Morning Sky):

Venus once again achieves greatest brilliancy (magnitude -4.2) on the 9th, this time in the morning sky. It still appears low in the east, rising 1½ hours before the sun in midmonth. This brightest of all planets appears near the crescent moon on the 15th.

Jupiter, in Capricornus, rises in the east about 1 AM local daylight time in midmonth and is low in the SSE before sunrise. The light yellow planet has brightened to magnitude -2.

Saturn, at opposition to the sun, crosses the southern sky and sets in the WSW at sunrise.

### Meteor Shower:

The May or Eta Aquarid meteors, radiating from the Water Jar in Aquarius, attain a peak on the morning of the 4th at a rate of about 20 per hour. Unfortunately, this year the date coincides with a full moon which will severely hamper observations. The meteors are swift and leave very long trails before vanishing. The May Aquarids, lasting from about the 1st to the 8th, are strictly a morning display since their radiant point does not rise until well after midnight.

### Moon Phases:

Full moon--May 4  
Last quarter--May 11  
New moon--May 19  
First quarter--May 27



### The Stars:

The Big Dipper swings around the sky's north pole and is poised upside-down this month in its best viewing position of the year. Further, this easily recognized pattern of seven stars serves as a built-in pointer system to other stars. The two western stars of the dipper's bowl point to Polaris the North Star; the two eastern bowl stars point to Regulus, the heart of Leo the Lion; and the bent handle, if extended, curves to bright orange Arcturus (in Bootes) and then continues an equal distance to blue-white Spica (in Virgo). The brightest nocturnal star Sirius now sets in the WSW about 9 AM daylight time in midmonth. Reddish Antares (in Scorpius) rises in the ESE about 9:30, while Vega (in Lyra) is now well up in the NE as dusk ends.

# DIRECTOR'S MESSAGE

by  
Walt Andrus

The MUFON 1985 UFO Symposium will be held June 28, 29, and 30, 1985, at the Chase Hotel in St. Louis, Missouri, with the challenging theme "UFO: The Burden of Proof." For details concerning speakers, titles of their papers and reservations, please refer to a separate article in this issue of the Journal.

**Marge Christensen**, Director of Public Relations, has announced that August 18-25, 1985, has been designated as "National UFO Information Week." All State and State Section Directors should start making specific plans for public UFO exhibits, showing of UFO video documentaries, one-day UFO conferences, and a news media blitz as a means of public education to this continuing phenomenon -- the greatest scientific mystery of our time.

\*\*\*

**Robert M. Hendricksen, Jr.**, Ph.D., a MUFON Consultant in Entomology, has accepted the position of State Director for Delaware replacing **Juan J. Magrans** who will continue to be the State Section Director for New Castle County. **G.D. (Dave) Berryhill, Jr.**, M.D., State Director for Mississippi, has moved from Clarksdale to Dublin where he will engage in Emergency Medicine. His new telephone number is (601) 624-6653. As State Director, Dave has launched a program to organize Mississippi through membership recruitment, selection of an Assistant State Director, Public Relations Director and additional Section Directors.

**Jerry L. Sievers**, presently the State Section Director for Knox, Daviess and Sullivan Counties, was promoted to the additional responsibility of Assistant State Director for Indiana. Jerry is taking positive strides to strengthen the southern half of Indiana through existing Section Directors. The Unexplained Phenomenon Research

Organization (UPRO) is now scheduling monthly meetings. **Floyd N. Petri, Jr.** is the new State Section Director for Bastrop and Travis Counties in Texas. His civilian law enforcement and military experience are an asset to him in Field Investigations. With the support of MUFON, Floyd is organizing a UFO field investigative team to be known as PULSE (Project UFO Landings, Sightings, and Entities) or simply PRG for Pulse Research Group.

\*\*\*

Two new members have been added to the MUFON Staff in order to stay abreast of advances in state-of-the-art technology. **Michael D. Hart**, currently State Section Director for King County in Washington, and Director of the Compufon Network will head up MUFON's Computer Science activities and planning. Mrs. **Sandra Pfullmann**, who has an Associate Degree from San Antonio College in video technology is our new Video Technician. One of her first official assignments was the filming of the MUFON Seguin segment of the new one hour MUFON video program titled "UFOs: A Scientific Engima," being produced by Marge Christensen and narrated by Dr. David M. Jacobs. The following people have confirmed that they will participate in the program: Dr. J. Allen Hynek, Walt Andrus, John Schuessler, Budd Hopkins, Barry Greenwood, Dan Wright; Ray Fowler, and Paul Cerny (or Tom Gates). This video program in both VHS and Beta format will soon be available to State Directors for cable television and public relations programs. Marge and her P.I.P.E. Committee are to be commended for this ambitious project that certainly ranks as a first by any UFO organization. The proposed price is \$20.00 for each video cassette.

**Joseph K. Long**, Ph.D. of Plymouth, New Hampshire has joined MUFON as a Consultant in Anthropology. He is a professor at

Plymouth State College. We also welcome three new Research Specialists this month. They are Rev. **Jerry Doellinger**, M. Divinity, of Newton, Iowa in Theology; **Pete Bissonnet**, Crosby, Texas, in Propulsion Systems; and **James S. Hatem**, M.A. of Chatsworth, California in Anthropology.

\*\*\*

The MUFON Amateur Radio Net meets every Saturday morning at 8:00 a.m. EST or daylight savings time on 7237 kilohertz. The Net Control stations are N1JS, WA3QLW, and K8NQN.

Another valuable project has been completed by the P.I.P.E. Committee with the announcement by Dan Wright, State Director for Michigan, that two .35 mm slide sets, designed for public information and the second for training field investigators are now available. There are two versions of each set. The set of 50 slides will cost \$25.00, while the set of 100 slides will cost \$45.00. The package includes printed commentary, slides and slide box. Please order these slide sets directly from Dan Wright, 1502 Marquette, Lansing, MI 48906. These visual aids will fill a much needed void that has been desired for many years.

Dr. and Mrs. J. Allen Hynek are now living in their recently purchased home in Scottsdale, Arizona, only a short distance from their Arizona facility known as "CUFOS WEST," located at 6159 East Indian School Road in Scottsdale. The official name of the Arizona facility is "UFO Phenomenon Research Facility" to emphasize the fact that one does not really do research on UFOs, but on the UFO phenomenon, the existence of which is undeniable. For further details and operation of CUFOS as an organization, please refer to the International UFO Reporter, January/February 1985 issue.

(continued on page 19)

# MUFON UFO JOURNAL

NUMBER 205

MAY 1985

Founded 1967

OFFICIAL PUBLICATION OF



MUTUAL UFO NETWORK, INC.

\$1.50



## UFOS: THE METEOR CONNECTION

**MUFON UFO JOURNAL**  
 (USPS 002-970)  
 (ISSN 0270-6822)  
 103 Oldtowne Rd.  
 Seguin, Texas 78155-4099

**DENNIS W. STACY**  
 Editor

**WALTER H. ANDRUS, JR.**  
 International Director and  
 Associate Editor

**THOMAS P. DEULEY**  
 Art Director

**MILDRED BIESELE**  
 Contributing Editor

**ANN DRUFFEL**  
 Contributing Editor

**TED BLOECHER**  
**DAVE WEBB**  
 Co-Chairmen,  
 Humanoid Study Group

**PAUL CERNY**  
 Promotion/Publicity

**MARGE CHRISTENSEN**  
 Public Relations

**REV. BARRY DOWNING**  
 Religion and UFOs

**LUCIUS FARISH**  
 Books/Periodicals/History

**ROSETTA HOLMES**  
 Promotion/Publicity

**GREG LONG**  
 Staff Writer

**SIMONE MENDEZ**  
 Staff Artist

**TED PHILLIPS**  
 Landing Trace Cases

**JOHN F. SCHUESSLER**  
 Medical Cases

**LEONARD STRINGFIELD**  
 UFO Crash/Retrieval

**WALTER N. WEBB**  
 Astronomy

**NORMA E. SHORT**  
**DWIGHT CONNELLY**

**DENNIS HAUCK**

**RICHARD H. HALL**

**ROBERT V. PRATT**

Editor/Publishers Emeritus

The MUFON UFO JOURNAL is published by the Mutual UFO Network, Inc., Seguin, Texas. Membership/Subscription rates: \$15.00 per year in the U.S.A.; \$16.00 foreign in U.S. funds. Copyright 1985 by the Mutual UFO Network. Second class postage paid at Seguin, Texas. POSTMASTER: Send form 3579 to advise change of address to The MUFON UFO JOURNAL, 103 Oldtowne Rd., Seguin, Texas 78155.

# FROM THE EDITOR

As you can see from the line-up below, we've got a lot of ground to cover in this issue and not much room here above in which to do it! Our centerspread presents the second installment of Bruce Maccabee's fascinating survey of black UFOs, and James McCampbell leads off with another penetrating study of UFO physiological effects. Elsewhere you'll find the usual articles, artwork and departments that make the Journal the world-leader in its field.

If you're not actively supporting the Journal with your own subscription and urging it on interested friends and libraries, now, with the annual Symposium and National UFO Week coming up, is the time to ask yourself why. Future issues will be just as exciting, including Convention coverage and a special edition on government documents. Stay tuned and convince others to do likewise.

## In this issue

A TASTE FOR UFOS by James McCampbell .....	3
YAKIMA UFO by Greg Long .....	5
THE METEOR CONNECTION by Luis Schoenherr .....	6
UFO INSPECTS PLANT by John Schuessler .....	7
HIGHER DIMENSIONS by Daniel Eden .....	8
BLACK HOLE OVERTURE (part II) by Bruce Maccabee .....	10
MUTE EVIDENCE REVIEWED by Robert Wanderer .....	14
LETTERS .....	16
STARS & PLANETS by Walter Webb .....	18
IN OTHERS' WORDS by Lucius Farish .....	18
DIRECTOR'S MESSAGE by Walt Andrus .....	20
COVER by Simone Mendez	

The Mutual UFO Network, Inc. is exempt from Federal Income Tax under Section 501(c)(3) of the Internal Revenue Code. MUFON is a publicly supported organization of the type described in Section 509(a)(2). Donors may deduct contributions from their Federal income tax. In addition, bequests, legacies, devises, transfers, or gifts are deductible for Federal estate and gift tax purposes if they meet the applicable provisions of Sections 2055, 2106, and 2522 of the code.

The contents of the MUFON UFO JOURNAL are determined by the editor, and do not necessarily represent the official position of MUFON. Opinions of contributors are their own, and do not necessarily reflect those of the editor, the staff, or MUFON. Articles may be forwarded directly to MUFON. Responses to published articles may be in a Letter to the Editor (up to about 400 words) or in a short article (up to about 2,000 words). Thereafter, the "50% rule" is applied: the article author may reply but will be allowed half the wordage used in the response; the responder may answer the author but will be allowed half the wordage used in the author's reply, etc. All submissions are subject to editing for style, clarity, and conciseness.

Permission is hereby granted to quote from this issue provided not more than 200 words are quoted from any one article, the author of the article is given credit, and the statement "Copyright 1985 by the Mutual UFO Network, 103 Oldtowne Rd., Seguin, Texas" is included.

# A TASTE FOR UFOS

By James McCampbell

Buried deeply within the vast literature on UFOs are a few minor and obscure details that, having been largely ignored, may be significant. These cases involve statements by the witnesses that they experienced a strange, metallic taste during and after a UFO observation at close range.

## Examples

Three hunters in the Ocala National Forest of Florida were looking for a lost deer hound at 9 PM on December 14, 1975. They spotted a hemispherical object 25 ft. high with five "legs" about 12 to 15 ft. long. Emitting a bright blue-white light, it hovered over a power line and then moved away as the witness approached to within about 250 yards.

During the half-hour observation, their CB radio failed, a humming sound was heard, a strange odor hung in the air, and "...they had a *funny* metallic taste in their mouths."<sup>1</sup> (Emphasis supplied by the present author.)

A Canadian case on October 23, 1967, involving 17 witnesses and five objects seems to be relevant, although the details are poorly described.<sup>2</sup>

A real estate salesman approached to within 250 yards of one of the objects that landed in a vacant lot of a housing subdivision that was under construction. "Everything he ate tasted the same and there was a taste of copper or metal in his mouth."

The objects flew away over some power lines that lighted up and the salesman's car and the tall flagpole at the show house were later found to be magnetized.

The author recalls another incident in which the strange taste reportedly lasted 20 minutes but the reference cannot be located. (Any assistance in finding it and other cases would be appreciated.)

These cases imply that some electrical or magnetic fields associated with the UFOs were responsible for

inducing the artificial sensation of a metallic taste.

A further hint in that direction came from a passing remark about a similar taste that had been experienced by a female friend while undergoing an electrical treatment for removal of excess hair on the jowls. The treatment involved the application of an electrode to the hair root while the opposite electrode was held in one hand.

In a later, tape-recorded interview, she said that the electrode was applied "...on the side of my face and the closer it was to the inside of my mouth, the more I could taste it. It tasted like eating tinfoil."

In answer to the question if the taste lasted very long, she said, "Well, after I would have the session it would probably last about 5 minutes or so."

## Electrology

Electrology is the name for the study and professional practice of permanent hair removal that is an application of the electro-chemical process known as electrolysis. It is regulated by law in most states that establish the academic and experience requirements for licensing.

Basically, there are two processes that are used separately or in combination. One is the application of a direct current whereas the other involves an alternating current of high frequency. The frequencies employed are restricted by the Federal Communications Commission to 13.56, 27.12, and 40.68 megahertz (million cycles per second), although most equipment operates at 13.56 megahertz.

Passing an electric current through a conducting fluid stimulates chemical reactions that would not otherwise take place. Treatment with direct current utilizes this process.

A tiny needle as a negative electrode is inserted into the follicle of the hair to be removed while the patient

holds a damp, cylindrical sponge in one hand which serves as the anode. Passage of a weak current through the patient produces a minute quantity of the hydroxyl ions (OH) near the root. This slightly caustic ion attacks the local tissues preventing regrowth of the hair.

The application of high-frequency current is based upon the local generation of heat to achieve the same result. The two processes are sometimes used simultaneously to accelerate the chemical reactions by slightly increasing the temperature.<sup>3,4</sup>

As the metallic taste in electrology treatment is of no consequence, References 3 and 4, being the only books on the subject that are presently in print, are silent on that side effect. But through the voluntary and enthusiastic assistance of a licensed electrologist, Mrs. Marianne Zehntner of Belmont, California, additional details were obtained.

In her experience, the taste occurred only when using direct current and it was not noted by people who wear dentures, have no dental fillings, or whose fillings are gold.

The taste is most prominent during an "after treatment" on the lower portion of the face. This treatment for conditioning the pores is performed with a small, free-rotating, conducting cylinder covered with a layer or two of damp gauze. It is gently rolled over the skin while applying a direct current as the cathode (negative).

With much scientific curiosity and a twinge of apprehension, the author undertook such a treatment and duly experienced the sensation as the device was rolled over the cheeks, lips, chin, and especially the jaws. The taste is hard to describe and the word "metallic" seemed to be inadequate. There was a tingling component and a strange bitterness.

(continued next page)

## TASTE, Continued

The location on the tongue was restricted to the lower edge of the front half where the tongue contacts the lower teeth. The intensity of the effect increased as the current was increased from 1.5 to 3.0 milliamperes.

### Scientific Data

While technical information on this subject is hard to find, it has been researched quite thoroughly in the physiological study of the sense of taste and an excellent survey article of the field was published in 1971.<sup>5</sup> The phenomenon was discovered by Sulzer a quarter of a century before the Italian physicist Alessandro Volta did his pioneering development of electricity.

Sulzer experienced the taste when applying two dissimilar metals that were touching each other to the tongue. Students of physics will recognize that arrangement as a primitive battery with the tongue completing the circuit. The phenomenon was then forgotten and rediscovered in 1792 by Volta, who described the sensation as definitely sour with the positive pole applied to the tip of the tongue (due to hydrogen ions) but, with the negative pole to the tongue, "...no longer sour but more alkaline, sharp, nearing bitter."

Then followed nearly 200 years of progressively more intensive and sophisticated research as the knowledge and theory of electricity expanded and as the science of physiology was born and matured. There was always much difficulty in describing the taste; terms included bitter, alkaline bitter-sweet, bitter-sweet, and sometimes metallic.

Here are briefly summarized the scientific facts pertaining to the present injury. Individuals are highly variable in their responses; however, mean thresholds for detection are on the order of 100 microamperes and the sensation gains intensity as the current is increased, in a linear or somewhat stronger dependency.

The onset of the taste is almost immediate and reaches full magnitude within a fraction of a second. Upon shutting off the current, however, the sensation does not cease but persists for a long time. A continuous sensation

is experienced with direct current pulses as slow as 0.5 per second.

Some experiments with alternating current showed that it was hard to detect any taste at frequencies greater than 1,000 Hz. While the cause of the sensation has not been unequivocally established, it appears that the so-called metallic taste at the cathode is a combination of direct action of electricity upon the taste cells and the normal, chemical effect of products of electrolysis.

### Evaluation

The known parameters of "electric taste" in the science of physiology are thus seen to correspond quite closely with the side effect from electrology treatments and the reported experiences of some UFO witnesses. And some of these parameters can be useful in inferring the probable stimuli in the UFO cases.

A great deal of evidence points toward a compound, electro-magnetic field near UFOs that consists of (a) rapidly-pulsed microwaves<sup>6</sup> in conjunction with (b) a slowly-pulsed, magnetic field.

During the open forum period at the Second International Conference sponsored by the Center for UFO Studies in November 1981, the author described the requirements of a magnetic field that would cause a compass to spin steadily, a rather common element in UFO reports. Basically, the field intensity must be on the order of the earth's magnetic field (0.2 gauss) and the pulse rate must synchronize with the compass spin rate.

These concepts from physical intuition were later verified by the author in crude, "poor-boy" experiments that were instrumental in formation of a group at the MUFON 1983 Symposium to repeat the experiments with scientific precision.

The "poor-boy" tests showed that a card compass exposed to pulsing fields of roughly 0.1 gauss up to 0.6 gauss caused it to spin steadily at rates ranging from about 35 up to about 125 rpm in proportion to the field strength at its peak value. Corresponding magnetic pulse rates in sync with the compass were 0.58 to 2.1 per second.

Much stronger fields were required to spin a liquid-filled compass whose dynamic behavior is dominated by viscous damping by the fluid that is, of course, its primary purpose. Spin rates for a wet compass were much slower, ranging from about 6 to 20 rpm. Corresponding magnetic pulse rates were approximately 0.1 to 0.33 per second.

In UFO cases where compass spin rates were measured or where they can be estimated from the description by the witness, the pulse rate of a magnetic field that could sustain a steady spin can be inferred directly. For example, suppose that a compass were observed to spin at 15 rpm, the driving pulse rate would be 0.25 per second.

Pulsed magnetic fields are very likely the cause of spinning compasses because they are sufficient and no competing cause has been suggested. Also, when a simple solution to a problem is at hand, there is no need to search for a complicated one.

Recall that Mrs. Zehntner said that the metallic taste was experienced only with direct current. Furthermore, scientific research has shown that the effect does not occur at frequencies above about 1,000 Hz. Based upon this information, it is possible to ascertain which type of field from UFOs could be responsible.

The microwave radiation must be ruled out in favor of a slowly-pulsed, magnetic field. Also recall that DC pulses as slow as 0.5 per second in the scientific studies showed the sensation to be experienced as continuous. Due to the known, long persistence of the taste, even slower pulse rates of the driving current could hardly be detected.

How could the requisite current arise in the presence of a UFO? A fundamental concept in electricity is that a moving conductor cutting magnetic field lines will induce a current in the conductor. Stated alternately, transient magnetic field lines moving past a stationary conductor will induce a current in the conductor.

(continued on page 15)

# YAKIMA UFO

By Greg Long

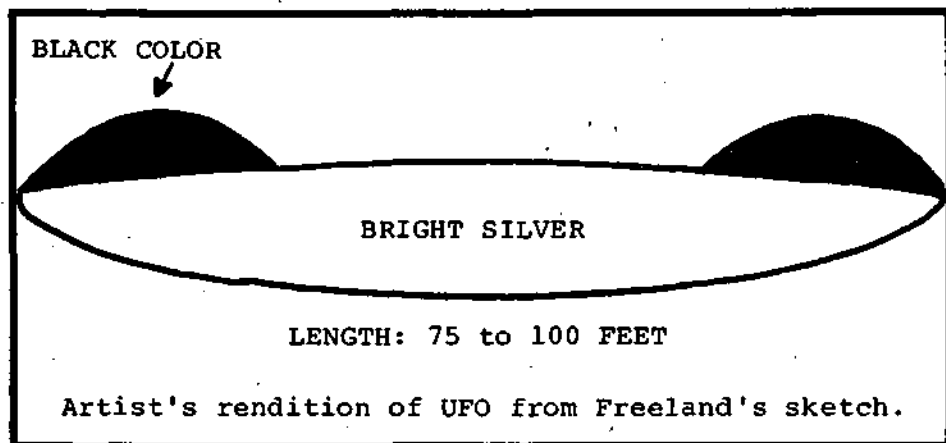

During my research into UFO sightings on the Yakima Indian Reservation in south-central Washington state, I came across the sighting of a Daylight Disc observed in 1971 from a fire lookout station on a mountain outside the Reservation.

B. (for Barbara) Ann Slate, a Bigfoot and UFO researcher who published her findings in popular magazines in the mid-1970's (and who died in 1978), began corresponding with W. J. (Bill) Vogel, the UFO investigator on the Reservation, in 1974. Vogel provided Slate with material for articles on UFO and Bigfoot sightings. One of her *Saga* magazine articles drew a response from Gary B. Freeland, a fire lookout who had spent 18 summers on forest lookout stations in Oregon and Washington. Slate passed Freeland's letter onto Vogel.

Freeland's sighting occurred in mid-July 1971. "I view myself as a credible individual," he wrote to Slate in his March 5, 1975 letter, "and not given to rash judgements.... I hold two Master's degrees, have been a teacher for seven years, and for the past 2½ years have been a guidance counselor. I also have piloted aircraft for 60 hours...." He described his sighting thus:

"In brief, this is what occurred. The lookout is on [6,300-foot high] Timberwolf Mountain

northeast of Mount Adams about 30 air miles [and 24 miles due west of Naches, Washington.] I had just taken a bowl of soup outside the cabin—a ground station—to eat my lunch. The day was exceptionally clear, nary a cloud around.

## HELICOPTER?

"I sat down on the steps and turned on my radio to hear the noon news— Paul Harvey, I think. I looked up in the direction of Clemens Mountain (it also has a lookout station—state controlled; distance about 8 miles). I then saw what first appeared to be a large helicopter—the double-rotor type with a motor on either end. But the craft made no thrashing sound as do choppers at that distance. It made absolutely no noise. It simply held a suspended position above the Yakima end of the mountain.... Its altitude appeared to be about 7,500-8,000 feet, which caught my immediate attention. I never had seen a 'copter hover at such a high altitude. Such copters had passed infrequently through the area over the summers I had been on Timberwolf and Little Bald Lookouts. Other types, military and otherwise, had frequented our districts, too. And when they were much farther away, the

unmistakable whump-whump of the rotors could be heard.

"I observed the craft for some 15 seconds. It still didn't move. I got up and ran into my cabin and got my 7.50 x 50 binoculars. For about a full minute, I observed the craft. It was cigar shaped and silvery except for two dome-like protrusions on opposite edges of the craft. That's why I first believed it to be a double-rotored helicopter. But the domes were rounded, not rectangular as on the helicopters. And there was no rotor evidence, and no sound. The craft turned slightly as to reveal the sun glinting on its silvery side. Too, the craft was thinner than the helicopters I've seen. You see, I lived for a couple of years in Imperial Beach, California, smack up to the helicopter training base at Ream Field. And I've seen and heard those damn choppers day and night for all too long a time. I know well what they sound and look like. At 8 to 10 miles they're terribly loud. Even when nearly out of sight they're quite loud. If what I saw had been an airplane or a helicopter, it would have drifted away slowly enough so I could have followed it with the binoculars. But not this. It simply disappeared; that is, I lowered my glasses a second, raised them again, and the craft was gone! I never reported the sighting to authorities, except for my boss at the ranger station."

## RECONFIRMED

Recently I managed to make telephone contact with Freeland 13 years after his UFO sighting. Freeland's memory of the incident was remarkably clear, down to the details of who was on the radio, the time, what he was eating for lunch, and the 60-second duration of

(continued on page 15)

# THE METEOR CONNECTION

By Luis Schoenherr

In a recent article in the *Journal!* the authors have speculated, whether the temporal correlation of UFO sightings and satellite re-entries is "coincidence or cunning". They suggest it could be the modus operandi of extraterrestrial visitors to use re-entry phenomena in order to mask their own operations.

In this connection it may be pointed out that there have also been cases of UFO sightings correlated with meteoritic falls. I have never made a systematic search for such cases, but when reading the article cited above, I immediately recalled two American sightings:

## STOCKTON, KANSAS

At approximately 3:50 p.m. (MST), February 18, 1948, at the onset of or just before the Norton County meteoritic fall, <sup>2</sup> a Stockton farmer claimed he saw "a strange saucer wobbling over his home". He said further: "When it came within six feet of him it stopped in the air, level with his face, and wobbled around for an instant with fire belching out, and then being sucked back in. It was about four feet long and shaped like a funnel. Sparks suddenly showered from it and the fire increased as if a fuse had been lit. It took off in a northwest direction, very fast, gaining altitude as it went. My wife came out and watched it fly off, leaving a trail of smoke. On a sudden, a great cloud of smoke appeared in the sky and in a few seconds, we heard a terrible explosion. I could feel the heat from where the object came near the ground."<sup>3</sup>

## CROUTER FARM, NEBRASKA

On July 28, 1968, at approximately 2:00 p.m. (i.e., about the time of the Omaha Fireball: 1:45 p.m.), the railroad engineer William C. Rogers observed a tear-drop shaped phenomenon of light, 100 feet from him at the height of the power lines, which cross the farm. While the observer watched, it burst

open and disintegrated into fragments of light. The phenomenon made no noise nor did it leave physical traces. It did also not move. The sky was cloudless and sunny and the incident lasted "a small number of seconds". Later the witness corrected his distance estimate to 200 yards, a still later measurement resulted in 750 feet.<sup>4</sup>

## DISCUSSION

The wording of the Stockton report renders the impression that two separate events are described and that the observers were in an environment familiar to them. Nothing is known about their eyesight and credibility. But if the report is not an outright hoax or has not been fabricated by mentally deranged people, it is worthy of being considered. I'm wearing glasses, but I cannot imagine that I would, in broad daylight and in front of my house, mistake a meteoritic phenomenon dozens of miles away, for an object six feet from me and level with my face. And what about the heat the farmer felt "where the object came near the ground"? The only item in accordance with the hypothesis of a misidentification of the meteoritic event is the direction of flight (northwest) of the UFO.

One may also get the impression that the importance of visual defects for the reliability of an observation is often overemphasized. People who have such defects are usually well aware of them by long experience and know how far they can trust their eyes. There are carefully designed optical experiments which seem to prove how easily human perception is fooled. But actual observational situations are not like carefully designed optical illusions. There is, for example, a distinct difference in the sensory quality of close up observations and observations of things far away. This is due to the human ability of stereoscopic sight, which makes distance estimates in a

range of 2 to 4 meters possible without external reference points or knowledge of the nature of the observed object. Quite unconscious movements of the eyes, the head or the body together with the use of secondary criteria like perspective, shadows, definition and external reference points, can enlarge this range considerably.

Contrary to the Stockton sighting, the Rogers Case has been well investigated. It was established that the angle between the observer's bearing and the course of the meteorite was about 15 degrees. This and the short duration of the event could perhaps (perhaps!) explain why no motion was observed if the witness had actually seen the meteorite. But then, if the witness had really looked at such an acute angle towards the meteorite, why had he not seen the meteor trail, but insisted the sky was clear and cloudless?

This puzzled even the investigator. In the course of the investigation the witness admitted he could have been in error as to his original distance estimate. But it was only during the investigation, that he learned of the meteoritic fall. It is therefore equally possible that this led the witness to distrust his original estimate. It is interesting that the investigator himself has not discounted the possibility that Roger's first estimate might have been correct. In view of all this, years ago I tried to persuade the investigator of this case to also look into the Stockton sighting. But he declined, apparently in view of the elapsed time and the presumed unreliability of the available account.

## UFO CORRELATIONS

For there to be unambiguous correlations of UFO sightings with re-entry and meteoritic phenomena, the following requirements must be

(continued on page 15)

## UFO ROUNDUP

By  
John Schuessler

Probation officer Andrew Child and his wife Pam, a social worker, spotted a flying doughnut over Dorset, England in December 1984. They said "it was grey, doughnut-shaped, with a ring around the middle, and was at least the size of an aircraft."

They claimed it hovered at a 5000-foot altitude for 10 minutes, long enough to them to summon other witnesses. Although the object was clearly visible at the time the witnesses said they could see no markings of any kind. What did they think it was — "we are convinced it was a flying saucer."

Within a few days of the Dorset sighting a couple in Hunstanton said a large flying disc hovered over the road in front of their car. They said: "it was dome-shaped and it was all lit up a glowing orange color. It was fluorescent. It seemed to be moving slowly but without noise." The couple claimed they were not frightened, just excited.

Another UFO was reported on Christmas Eve by a lorry driver in Leeds. James Lenehan said he was walking his dog when he saw "a red airship." He said the sky was red when the airship came down to land behind the Kirkstall Museum. Someone said he saw Santa Claus making his annual rounds.

## ORANGE BALL

Similar sightings were occurring across the English Channel about the same time. Police in the Doubs region of France reported a number of calls about UFOs. A round object hovered over Lomont late in the afternoon on November 28. The next day a young woman reported a dark orange ball over the Mont-Bart forest. Other sightings were similar. One newspaper said: "five witnesses, five different persons, observing very strange phenomena from different locations. And not the slightest recognized scientific evidence." How can it be ignored? The people have a right to know.....

## PLANT INSPECTION

Thousands of people report UFOs passing over their homes and chasing their cars, and occasionally someone claims to have been taken for a ride in one of the mysterious objects. Once in a while, however, the UFOs ignore the witnesses to critically inspect a military installation, power plant or other seat of human technology. This is one of those stories.

The famed Center for UFO Studies in Evanston, Illinois, ran this copyright 1984 story in their newsletter. Although all rights to the story were reserved by the Center, they permitted this interesting account of a UFO inspecting the Boeing Aircraft plant in Renton, Washington.

A man and wife living atop a hill overlooking the plant about one mile away said they saw lights hovering over the south end of the plant. At first they believed the lights to be from a helicopter, but soon changed their mind as their experience became a close encounter.

## NO HELICOPTER

The lights shot up in the air briefly and moved to the north end of the plant. After a moment they left the Boeing plant and flew right up to the witnesses, stopping only 300 yards

away. It definitely was not a helicopter.

The UFO was circular with a curved top and sloping sides and about 50 feet in diameter and 15 feet thick. Windows encircled the craft and images could be seen moving around inside. Someone or something was piloting the craft. An amber light was located directly in the center of the top and the light from inside resembled a fluorescent light.

The witness said he studied the object as intently as possible as it hung there in the sky. It seemed to be constructed of a light-weight metal and seemed to give off a little glow making it easy to observe. He said there was no sound at all.

## MANUFACTURED

After a few minutes the UFO started to move away toward Lake Washington and had disappeared over the trees in about four seconds, but not without convincing the witnesses it was real. He said: "I had a good chance to study this thing and I'm sure it was...made by an intellectual....maybe somebody smarter than us....and it was a mechanical gadget, is what I'd call it. It was manufactured. It was no reflection or image or anything like that because that's what I wanted to be sure of. This was a mechanical machine."



UFO

# HIGHER DIMENSIONS

By Daniel Eden

The Berkeley educated, cosmic ray physicist, Dr. Karl A. Brunstein has courageously lifted the lid off a Pandora's Box by publishing his remarkable book, *Beyond The Four Dimensions: Reconciling Physics, Parapsychology and UFOs* (Walker And Company, 1979). Dr. Brunstein is offering an intellectual challenge to physics and to the still infant sciences of parapsychology and ufology to open their minds to the possibility of physically real higher spaces. With the awesome intuition of a modern Sherlock Holmes, he draws upon some of the bizarre clues that seem to link our four-dimensional world (height + length + width + time = 4-D) to that of a greater world of five or more dimensions.

From the dreamy halls of Einstein's Princeton retreat to the coffee-stained papers on the desks of the world's ingenious particle physicists, the data that hints of a higher space is beginning to show its hand. It's popping up everywhere! And as in physics and parapsychology, Dr. Brunstein shows that the little lame waif that is ufology is also reluctantly shuffling forward with the signposts to multiple dimensions.

## SHAPE CHANGERS

For instance, consider the many bizarre reports of UFOs that exhibit what Dr. J. Allen Hynek calls "strangeness". Metallic-appearing UFOs might saunter by a crowd of startled witnesses only to wink out of existence like a blown light bulb. In other cases they might fade gradually from view like some special-effects segment on a Star Trek movie. Sometimes UFOs are seen to race across the horizon while mysteriously changing their shapes in-transit, like those little toy cars that transform into robots with a flick of the wrist.

This very high strangeness can send a classical scientist scuttling back to his more mundane activities like a sand crab fleeing back into the safety of the ocean. But not every scientist runs

away. Dr. Brunstein calmly investigates, and analyzes, and then concludes that, "...a device moving about in accordance with the physical laws of a five-dimensional world and taking full advantage of that extra dimension — could be fully expected to manifest itself to us with just such a complement of mysteries."

Even the very conservative Dr. Hynek has been known to admit, within the pages of *OMNI* and *Technology Review*, that the higher space approach is at least one of the viable concepts that might help us to understand the UFO data. Other scientists are beginning to speak out on this possibility as well. While others, of course, just as strongly disagree.

## DISSENT

One strongly dissenting viewpoint comes from Robert Sheaffer who is sometimes called a "ufological theoretician" by one of his more dewey-eyed admirers. In his book, *The UFO Verdict* (Prometheus Books, 1981) Sheaffer seems very resentful that ufologists might have an interest in higher space theories. With an irritated sniff at Dr. Hynek's candor, he tartly quips "When Hynek speculates that UFOs, absurdities and all, are somehow penetrating into our dimension (sic) from some other level of reality, on what grounds could he possibly dismiss a sighting of the Easter Bunny?"

A much more rational criticism comes from the cryptozoologist J. Richard Greenwell. In an excellent article in Ronald Story's, *The Encyclopedia of UFOs* (Dolphin/Doubleday Books, 1980), Greenwell criticized higher dimensional theories, in general, for not having an "observational window" by which one could evaluate the reasonableness of the models. However, others would argue that it is the UFO, itself, that is the observational window just as subatomic particles are the windows

utilized by the particle physicists.

Another cryptozoologist, Jon Beckjord, offers a nice analogy for our consideration in CUFOS' *The Journal of UFO Studies* Vol. III, 1983. He says "Thus the next time we read of a UFO suddenly 'winking out' .... let's consider how a water strider insect views a rock being thrown in his pond. It sees not the flight of the rock .... all it sees in its plane of existence is the splash at entry. Are we much different?"

Clearly the "splash", as he puts it, is an "observational window" and the thing that is doing the splashing is precisely what all serious ufologists are vigorously striving to understand. From a series of careful measurements dealing with the nature of the watery splash, a little water-insect physicist could determine a whole host of useful features about his watery surface-space. He could indirectly determine the viscosity of the water, maximum wave velocities, and so forth. Permit me to reiterate Mr. Beckjord: "Are we any different?"

## HIGHER SPACE REAL?

With or without the support of such ufological theoreticians as Mr. Easter Bunny, the creative mathematicians and physicists of our time are delving deeply into notions of higher space. Perhaps the brilliant scientists who converged on the Second New Orleans Conference on Quantum Theory and Gravitation in 1983, could have used an Easter Rabbit for their mascot. Using abstract models with as many as 8-, 10-, and 12-dimensional spaces, they proved that higher space theories are really much more than Sheaffer's bunny analysis would suggest. Such theories can make testable, observable, predictions that can give us a greater insight into the mysteries of quantum phenomena, relativity, and maybe someday, ufology.

Are these multiple dimensions

(continued next page)

## DIMENSIONS, Continued

physically real entities? Dietrick E. Thomsen reported in *Science News*, July 7, 1984, that the scientists "are usually noncommittal about whether the extra dimensions are physically real or merely mathematical artifacts.... However, several of the others who spoke.... tended to talk as if the dimensions were real."

The issue is further complicated by the fact that in some of the models the higher dimensions are topologically wrapped around subatomic particles in a closed fashion so as to deliberately prevent any hyperdimensional interactions being predicted on a macroscopic level. However, by simply loosening up, or even dropping some of the more arbitrary restrictions on the models, it may be possible to encompass macroscopic phenomena, such as UFOs.

Many advanced models do not use the limiting restrictions of wrapped-off topologies and these models may be of more immediate interest to theoretical ufologists. For instance, the brilliant young mathematician Simon Donaldson, at Oxford University, has developed intriguing mathematical arguments, that suggest other 4-D worlds can exist independently of our own 4-D world. Clearly, this could have practical implications for ufology. If you have a strong background in advanced matrix mechanics on n-dimensional manifolds, you might want to seek him out to see if he has any positive ideas to offer to struggling, advanced-theory ufologists, if there are such pitiful creatures.

### HYPERDIMENSIONS

Not everyone has a graduate-level mathematical background to help them ferret out the useful elements of the more technical models. Nevertheless, many practical hyperdimensional concepts are easily within the reach of the researcher with an average intelligence who has a minimal math background. For instance, the award-winning science-fiction author (and mathematician) Rudy Rucker has written some wonderful little books, heavily illustrated, on the subjects of higher space. With his fortuitous background in math, writing, teaching,

cartooning and the reading of obscure sources, Rudy Rucker is one of the most literate, and intelligible, popularizers that the subject has ever had. I strongly urge the interested reader to prowl the local library for his books.

As with the emergence of any radically new way of looking at the world, the first applications of higher dimensional concepts to ufology will be fraught with errors, mistakes in reasoning, simple dead ends and heavy doses of criticism. However, I urge all serious ufologists to strive for openmindedness, or at least tolerance, towards those first pioneers who, like Dr. Brunstein, have the ironclad courage to take the first steps into these waters of unknown depths.

### FURTHER STUDY

For some easy-to-digest introductions to the various higher space ideas that are cropping up in modern science and math, please check out some of the following materials:

1. Edwin A. Abbott, *Flatland* (Dover Publications, Inc., N.Y., 1952) This is a reprint of the original 1884 edition. The author may have been

influenced by an earlier book (1879) called, *Transcendental Physics* by a German astronomer and physicist named Johann C. F. Zoellner. Johann was treated cruelly by his contemporaries and it may have inspired one of the fictional characters who appeared in *Flatland*.

2. Paul Davies, "The Eleventh Dimension," *Science Digest* (Jan. 1984, p. 72)

3. Ivars Peterson, "Shadows From a Higher Dimension," *Science News* (Nov. 3, 1984, p.284)

4. Rudy Rucker, *The 4th Dimension: Toward A Geometry of Higher Reality* (Houghton Mifflin Company, Boston, 1984)

5. Rudolf (Rudy) Rucker, *Geometry, Relativity and the Fourth Dimension* (Dover Publications, Inc., New York, 1977)

6. Gerry Segal, "The Fourth Dimension", *Science Digest* (Jan. 1984, p.68)

7. Dietrick E. Thomsen, "Many Dimensions in Gravity Theory," *Science News* (July 23, 1983, p.60)

8. Dietrick E. Thomsen, "Kluza-klein: The Koenigsberg Connection," *Science News* (July 7, 1984, p.12)



LEO  
©

# BLACK HOLE OVERTURE

-by Bruce Maccabee

## SIGHTING REPORT

*Date:* Sept. 2, 1984 (Sunday)

*Time:* object observed from just before 7:28 to 7:35 PM (plus or minus 1/2 minute) Eastern Daylight Time.

*Location of Witnesses:* near the northeast corner of the Light Street Pavilion at the Inner Harbor of Baltimore (see map).

*Witnesses:* known witnesses are Bruce and Christine Maccabee. Probable witnesses are several hundred other people who were facing east while listening to the concert; possible other witnesses are the several thousand other people who were in the Inner Harbor area that evening.

*Other reports:* none known to me.

*Weather and Environment:* clear blue sky with faint cloud wisps; sunset at 7:35; temperature in the 70's; light south wind at ground level. (Note: official surface weather observations from Baltimore, obtained from the National Weather Service, indicate that the weather conditions were essentially constant during the afternoon and evening of Sept. 2. At 7:52 PM the cloud cover is listed as 25000-scattered. The visibility was 12 miles. The wind was from the southwest [230°] at 5 knots. The upper altitude wind data at 6:00 PM from Sterling, Virginia, about 50 miles southwest of Baltimore, show that from about 1000 to about 3000 ft. the wind direction varied from southwest to west [about 220° to 270°] with speeds ranging from 15 to 20 knots. From about 4000 ft. to about 22,000 ft. the wind was from the west-northwest [in the range 290° to 300°] at speeds ranging from about 20 to about 34 knots. At even higher altitudes the wind was from the west.)

*Direction when first seen:* about 170° azimuth from true north; see 1 on map.

*Direction when last seen:* about 72° azimuth; see 5 on map.

*Apparent path:* the object traversed a total of about 100 degrees of azimuth from about 170° to about 72°. The elevation increased from about 15° when first seen to a maximum of about 35 to 40°, based on comparison with the approximately 30° angular elevations of the top of the mast of the Constellation and the top of the World Trade Center Building. At that time the azimuth was about 118° (see 2 on map). The elevation then decreased to about 25° when the object disappeared behind the Trade Center at an azimuth of about 96°. The elevation at reappearance on the north side of the Center, at an azimuth of about 85°, was much lower, perhaps 15°. Finally the elevation reached about 10°, remaining nearly constant during the last couple of minutes of observation when the object was definitely farther away than the Trade Center building, i.e., farther than 800 ft.

*Characteristics of the object:* it first appeared as a dark spot and it remained black as it grew in angular size. The outline (silhouette) against the sky continually changed, seeming to go through a cycle from generally round to generally elliptical or cigar-shaped. No brightness gradations were noted within the outline of the object in spite of a concerted effort on my part to see gradations or reflections of sunlight or something that would imply "solidity" (three-dimensionality) of the object. It was last seen as a barely distinguishable black dot against the sky.

*Angular size:* varied during the sighting. I estimate 1 to 2 milliradians at its largest, based on comparison with my small finger size during the sighting and upon subsequent tests with a millimeter ruler held at arms length.

*Shape:* the shape seemed to change continually. Most of the time the object appeared as a slightly distorted black disc (i.e., generally round). However, several times the overall shape of the object changed in a continuous manner

from round to elliptical or cigar-shaped. When this happened there seemed to be a very slight protrusion at the top.

*Other things in the sky:* bird at various distances; passenger jet aircraft; half moon in the southeast;

*Sound:* none noted.

*Rapid movements:* none noted.

*Color:* none (black).

*Effects on environment:* none noted.

*Visual acuity of the (main) witness:* able to detect a black spot on white paper if the angular size is about 0.2 mr (milliradian) or larger; can detect gross shape (outline) if the angular size is 0.5 mr or larger; can easily discern shapes if the angular size is 1 mr or greater.

## TRAJECTORY ANALYSIS

Initially both the angular elevation and the angular size of the object increased while the azimuth changed from about 170° to about 118°. These sorts of changes are consistent with an essentially level trajectory that would put the closest point of approach along the (approximately) 118° azimuth. Subsequently the angular size and angular elevation decreased, although the azimuth did not change as rapidly. These subsequent changes are consistent with a level trajectory that would take the object away to the east.

The actual range to the object at any time is not known, nor is its actual size. Therefore one can do no more than construct a family of curves representing likely trajectories at varying distances. Several possible constant height/constant size trajectories were configured, but are not shown. Of course, if one allows for the possibility that the size and/or height were not constant, then one could imagine many different types of trajectories.

(continued next page)

## BLACK UFO, Continued

### PROPOSED EXPLANATIONS

1) *bird*: It was not the correct shape although the angular size of the object was large enough so that wings, head, and body would have been resolved, based on comparing actual birds with the object.

2) *kite*: The flight dynamics were impossible for a kite since a kite is tethered. The shape did not coincide with that of a kite.

3) *aircraft*: A helicopter or other type of plane should have been easily recognized at the angular size of the object.

4) *balloon*: The general wind directions at various altitudes (generally southwest near the surface to generally west above several thousand feet) is consistent with the initial generally northward direction of motion of the object and with the subsequent northeast direction. Specifically, one might assume that the balloon was being blown generally toward the northeast at an altitude below 2000 ft. when it was first seen. As it climbed from, say, 1500 to 2500 ft. the wind changed its direction to nearly eastward. One might also assume that at the point of maximum angular elevation it was about 2500 ft. high and that by the time it disappeared behind the Trade Center building it was almost 3000 ft. high and heading eastward.

A consequence of assuming that the hypothetical balloon was at about 2500 ft. altitude at the point of maximum angular elevation (direction 2 on the map) places it at a (radial) distance of about  $2500/\sin 35 = 4360$  ft., and this distance requires a balloon diameter of more than 4 ft. corresponding to an angular size of 1 m or more. Obviously varying the assumed altitude by a few hundred feet (e.g., higher or lower than 2500 ft.) would result in variations in the required balloon size.

Considering the size one might assume that what was seen was a moderately large (round) black pilot balloon.

Although one may point to a rough overall consistency between the observational data and any one of a



number of trajectories suggested by the balloon hypothesis, when one begins to consider the finer details of a particular trajectory that seems to be mutually consistent with the weather data and the observational data, one may find inconsistencies.

For example, consider a trajectory which has been chosen to give reasonable agreement with the observed trajectory from the time of the initial sighting to the time of the maximum elevation and to be consistent with the weather data. Assume that the balloon was at an altitude around 1500 ft. when it was first seen in the south at an angular elevation of about  $15^\circ$ . At this elevation the wind would have been blowing the balloon toward the northeast at a speed of about 16 knots, according to the weather data. An altitude of 1500 ft. and an elevation of  $15^\circ$  corresponds to a (radial) range of about 5800 ft. At this range the angular size would have been smaller than when the balloon was at the 2500 ft. altitude and 4360 ft. away, so the angular size would have increased continually from the time of

first observation to the time of maximum elevation. To reach the 2500 ft. altitude in the first minute and a half of observation time would require an ascension velocity of 1000 ft. in 1.5 min. or 670 ft./min., which is on the high side of what is expected for a typical several-foot diameter balloon, but which is probably acceptable. So far, so good.

### NO BALLOON

From initial observation to the time of maximum elevation the azimuth changed by about  $(170-118)=52^\circ$  and the elevation changed by 1000 ft. By using some trigonometry and the law of cosines one finds that the linear distance between the initial point of observation and the point of maximum angular elevation is about 4500 ft. The distance along any other path (e.g., a path curved by the changing wind direction) would be longer. The wind speeds in the altitude range 1500-2500 ft. were around 12 knots (= 12 nautical miles/hr.; 1 nautical mile = 6077 ft.) or

(continued next page)

## BLACK UFO, Continued

about 1200 ft./min. To travel more than 4500 ft., then, would require more than 3.8 minutes, not the 1.5 minutes that is consistent with the observational data. In other words, this hypothesis fails because to make it fit the observations one must assume a wind speed that is more than twice the actually measured speed.

Using a similar calculation method one can show that in order for the hypothetical balloon to disappear at an angular elevation of  $25^\circ$  about 30 seconds after it was at its maximum angular elevation, the wind speed between 2500 and 3000 ft. would have to be about 61 knots. The actual wind speed in that altitude range was less than 20 knots (the highest measured wind speed at any altitude was 47 knots at 44000 ft.). Thus again the balloon hypothesis fails.

After analyzing a number of similar trajectories I conclude that it would be difficult, if not impossible, to find a balloon trajectory that is mutually consistent with the available upper altitude wind data and also with the observational data.

Besides the problem of finding a satisfactory trajectory, there is the problem that even a black balloon should have a brightness gradation in sunlight and perhaps even a glint, but this object had no such brightness gradation within its outline, so far as I could tell.

Another important reason for rejecting the balloon hypothesis is the nature of the continual change of the shape of the outline. The shape change was not consistent with the constant round or teardrop shape of a balloon, even though a balloon rocks back and forth as it rises. If I had only seen the object for a short period of time (less than 30 sec.) I might be satisfied with the free-floating black balloon hypothesis.

However, after watching it go through its unusual cycle of shape change and after failing to detect any brightness gradations at all within the outline over a period of more than a minute and after pondering the requirements imposed upon the balloon hypothesis by the observed

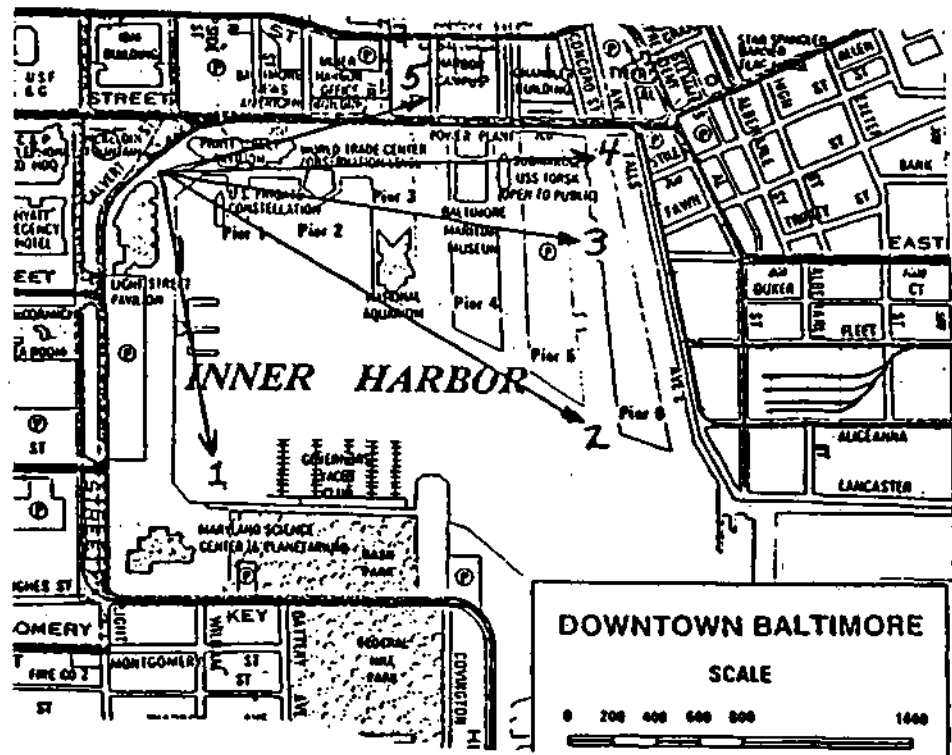

1 -  $170^\circ$ ; 2 -  $118^\circ$ ; 3 -  $96^\circ$ ; 4 -  $85^\circ$ ; 5 -  $72^\circ$

trajectory, I find it exceedingly difficult to accept the idea that the object was a balloon.

## MORE BLACK UFOS

At the time of my sighting it seemed to me that black UFOs had been reported before, but I could not remember any particular sightings except a few photographic cases in which portions of the photographed objects were dark or black. I did not remember reading about any sightings similar to my own.

After I had completed the above report I made a brief search of the literature and was surprised to find that black objects had been seen long before my sighting. In fact, the first report of a black object in the sky was made by a reporter, Dave Johnson, in July 1947. He was flying in a small plane looking for "flying saucers" to confirm Arnold's sighting when he saw a black object come out of a distant cloud. He photographed the object but it was too distant to make a useful image on the film.

While reading through early reports recently released by the Army I came, quite by chance, upon the following report, which has never before been published. The report was

made by Norman H. Brown, Acting Chief, Review and Analysis Section, Atomic Energy Commission. It was filed as an "Air Space Violation at Oak Ridge, Tennessee" on July 27, 1953. The report reads as follows:

"At approximately 3:00 PM on July 19, 1953, an F-86 aircraft was observed flying over Oak Ridge residential area, making circles at what appeared to the writer to be approximately 2,500 to 3,500 ft. The F-86 flew over the area in this manner for approximately ten or fifteen minutes. The writer, together with his wife, observed the aircraft through a pair of six power field glasses. After the aircraft flew in what appeared to be the direction of Knoxville, Tennessee, a black object moved out of a high white cloud, directly over the area the F-86 had been flying. This object began to travel at a tremendous speed, in a large circle.

"This action on the part of the unknown object continued for at least five minutes. During the circle of this object, it appeared at times to be in the shape of a cigar and at other times round. This object was

(continued next page)

## BLACK UFO, Continued

extremely black in color, having an appearance of a deep black metal exterior with a fine gloss. It did not leave a vapor trail or were there any lights shine (sic) noticed. No sound was heard. The object flew east at a tremendous speed for what appeared to be approximately three miles where it stopped. The objects (sic) was then joined by two more of these same objects. A formation similar to a spread 'V' was formed and the objects, at a tremendous speed flew in an eastward direction."

Upon reading this report I was struck in particular by the description of the blackness of the object and also by the description of the object looking round part of the time and cigar-shaped part of the time.

### BLACK ELLIPTOID

I found another detailed report in the book *UFOS: INTERPLANETARY VISITORS* by Raymond Fowler (Exposition Press, Jericho, NY, 1974). Fowler described a sighting by his brother on October 1, 1964. His brother reported:

"I had just driven into the rear parking lot of Sylvania on Endicott Street in Danvers. I was accompanied by two friends who were returning from lunch with me. We remained in the car talking for a few minutes when Mr. T. called our attention to a jet airliner flying over. One moment later, I looked up to see a dark, elliptical shaped object passing through the sky in front of and below a large cumulous cloud.

"At first I thought it was a sea gull, and since both Mr. T. and Mr. E. knew of my interest in UFOs, I jokingly said 'Look, there goes a flying disc.' In a few seconds, I realized that it was not a gull and immediately tried to get Mr. T. to look at it. (Mr. E. was in the rear seat and had little opportunity to catch sight of it.) Mr. T. never got a close look at it. It looked metallic and elliptical in shape, like a phonograph record seen at an

angle."

Fowler reports that his brother made reasonably careful estimates of the angle of elevation (30 deg) and the apparent diameter (3/16 of an inch at arms length which corresponds to about 0.008 radians or about 27 min of arc.) His brother had estimated that the object had been about 500 feet below the bottom level of the clouds, which were at about 2,500 feet according to the Weather Service. Using the estimated elevation and altitude the range is estimated as  $(2000/\sin 30^\circ) = 4000$  feet, and the diameter is then estimated as  $(2000/\sin 30^\circ) = 32$  feet. Fowler also estimated that the speed was about 300 mph.

There may be more explicitly described daylight sightings of black objects in the literature, but I am not aware of any. I do know, however, that as of the end of 1952 the Air Force had recorded 12 sightings of 7 black objects (Project Blue Book special Report #14). NICAP listed 57 sightings as of 1964. Unfortunately a number of these sightings are probably of dark objects seen at night, so whether they were actually black or not could not be determined from many of these reports.

After I had completed this appendix I read of another interesting report of a black object. The report, entitled "Minnesota Flying Black Hamburger," is published in the CUFOS Associate Newsletter (Center for UFO Studies, Lima, Ohio 45802; Dec.-Jan., 1984/85).

The report was received at CUFOS within weeks of the sighting on Sept. 2, 1982. The main witness was a former Army air traffic controller who claimed that he had seen "many things

in the air including sun dogs, 'skyhook' balloons, meteors, auroras, weather balloons, parachutes and a wide variety of aircraft."

At about 7:15 PM Central Daylight Time he was standing outside his garage. The sky was clear and the sun had not yet set. He heard the engine of a light aircraft and looked into the sky, seeing a small plane. Looking away from the plane he chanced to see another moving object about the same apparent size as the airplane, and possibly lower. He reported "My first thought was that it was a balloon being towed by the aircraft. That theory was shot down when the track of the object turned from due east to about 110 degrees, true. It maintained the same speed, that is (matching) the pace of the aircraft, probably 80 to 90 knots. There was a westerly wind at the time."

The witness watched the object travel into the distance. He estimated that the total sighting duration was about 3 minutes. He described the object as hamburger-shaped with a black top and a black bottom (the "buns") and a shiny central ("equatorial") part (i.e., the "beef").

Specifically he stated: "The bottom and top of the object were a jet black and probably a gloss finish. The equatorial band was metallic high-polished silver with a hint of rainbow reflections characteristic of diffraction grating material. The band also appeared to be recessed slightly, or at least gave that visual impression."

He described the motion as "smooth, holding the equator parallel to the ground with a few wobbles that reminded one of the precession of a top." He heard no sound from the object.

**MUFON AMATEUR RADIO NET**  
**EVERY SATURDAY MORNING**  
**AT 0800 EST**  
**(OR DST)**  
**7237 KHz. S.S.B.**

## BOOK REVIEW

**MUTE EVIDENCE**, by Daniel Kagan and Ian Summers, Bantam Books, 1984, 502 pp., \$4.95.

From 1967 and on through the 1970s, a major flap of "mutes"—reports of cattle mutilations—swept Colorado and neighboring states, and to some extent across the country and into Canada. More than 10,000 animals, mostly cows, allegedly died bizarre deaths and showed wounds cut with "surgical" precision. Some of these deaths were linked to mysterious helicopters or UFOs.

At the 1983 MUFON conference in Pasadena, Peter A. Jordan presented a paper on his investigation of the issue, a paper particularly valuable because he had expected to find evidence of "mutilations" but instead concluded that they could be explained as normal damage by predators. In *Mute Evidence*, authors Daniel Kagan and Ian Summers do a similar but considerably more extensive job of investigation. They have talked with everyone they could find who had any connection with the phenomenon—the ranchers who reported the "mutes," the sheriffs and others who investigated them, the newspaper and TV people who reported them, the pathologists knowledgeable about the physiology of what happens when an animal dies, and apparently anyone else who had anything to say.

To illustrate the thoroughness of their research: one of the authors (Kagan) interviewed Leo Sprinkle, a UFO enthusiast best known for conducting hypnosis, although he had only a peripheral connection with cattle mutilations. Kagan wanted to learn more about Sprinkle, so he allowed Sprinkle to hypnotize him. Sprinkle blew it: he blatantly confabulated a suggestion that Kagan add some UFO imagery to his hypnotically-produced story, which had no connection with UFOs; the interruption jarred Kagan out of his deep trance and left him with an insight on how Sprinkle produces so many "abduction" and other UFO tales from the people he hypnotizes.



Butchered bull in Isla Mujeres, Mexico

*photograph by Wendy Smith*

The book's conclusions:

- Virtually all the reported mutilations are the result of predators and other natural causes.
- A very few animals might have been cut by pranksters responding to extensive publicity on "mutilations," and a very few might have been the result of "cult" activity—no final conclusion could be reached on the cult possibility.
- Much of the concern about "mutilation" stemmed from greatly exaggerated stories in newspapers and on television. Part of this came from fact-bending, such as by the sheriff who claimed a dead cow was found in a tree (where it must have been placed by a UFO or other aircraft) when it was actually found at the base of the tree (where it was probably killed by lightning).
- The heart of the "mutilation" phenomenon was "a crew of UFO buffs who had branched out to specialize in cattle mutilations (pg. 487)."
- There was simply no evidence for any of the other suggested "explanations"—chemical warfare experiments, radiation and pollutant monitoring, psychological warfare and other "secret conspiracy" theories.
- Above all, the "mute flap" demonstrates how the power of the

media interacting with an idea that many people would like to believe came together to create a movement that acquired a life of its own, even though the basic assumptions were never verified.

That figure of 10,000 mutilated animals" also turned out to be a ballpark guesstimate one mutilation buff had dreamed up, although the number of reports was not even remotely near that.

I found this book an impressive study not just of the phenomenon but of how to investigate such a phenomenon. The authors ran down every lead and they report everything they learned—the book runs over 500 pages. Believers in "mutology" won't like the conclusion. But they will find it hard to come up with an alternative explanation, given the thoroughness of this study.

—Robert Wanderer

-----MUFON-----

**AMATEUR RADIO NET**

**EVERY SATURDAY MORNING**

**AT 0800 EST (OR DST)**

**ON 7237 KHz S.S.B.**

## TASTE, Continued

### Summary and Conclusion

Taste sensations reported by UFO witnesses at close range are in complete accord with the sensations experienced by patients taking electrolysis treatments. The latter are produced only by direct current and scientific research has shown that the sensation does not occur at high frequency. Consequently, the UFO witnesses must have been exposed to a magnetic field that induced a current in their bodies that functioned as antennas.

As only transient fields are effective, they must have been pulsed; the intermittent stimuli cannot be detected by taste. From crude experiments with spinning compass driven by magnetic pulses, the pulse rates from UFOs have been determined to within a rather narrow band. The same experiments yielded rough estimates of the field strengths required to drive a compass at a given speed.

Precise knowledge of these two parameters is expected from the current research by the MUFON Southern California group. Also, further insights may be obtained from the application of antenna theory to calculate the conditions necessary for the magnetic field to induce a minimum detectable current.

In a word, UFO witnesses who reported a strange, metallic taste in their mouths may have been exposed to pulsed, magnetic fields that produced a well-known phenomenon.

### REFERENCES

1. Jones, Jim, *Untitled report in UFO Network, Argosy UFO*, p. 6, September 1976. Also published in *The APRO Bulletin*, Vol. 24, No. 7, p. 2, January 1976 including a sketch of the object.
2. Smith, Wilbert B., *The Boys From Topside*, Edited by Timothy Green Beckley, p. 87, Saucerian Books, Clarksburg, West Virginia, 1969.
3. Hinkel, Arthur Ralph, and Richard W. Lind, *Electrolysis, Thermolysis, and the Blend, the Principles and Practice of Permanent Hair Removal*, Arrowway Publishers, 1968.
4. Shapiro, Julius, *Electrolysis, Beauty and Confidence Through Permanent Hair Removal*, Dood-Mead & Company, 1981.
5. Bujas, Zoran, *Electrical Taste*, Chapter 10, *Handbook of Sensory Physiology, Volume IV, Part 2, Chemical Senses*, Lloyd M. Beidler,

Editor, Springer-Verlag, 1971.

6. McCampbell, James M., *UFOlogy, Celestial Arts, 1973 and subsequent articles and papers.*

© 1985 James McCampbell

## YAKIMA UFO, Continued

the sighting. He also pinpointed exactly the location of the object. He did add a detail not in the 1975 letter: the surface of the object seemed to be made of metal sheets as if riveted together. He emphasized, as in the letter, the lack of sound and lack of rotors, windows or markings.

I also found Freeland's original supervisor, Walter Tokarczyk, who remembered Freeland well. He described the fire lookout as responsible who never reported UFOs, although he did not remember this particular sighting. Tokarczyk, now retired, recalled no other UFO reports from fire lookouts he supervised.

What did Freeland see? The clear July sky eliminates a cloud as a possibility, leaving aircraft as a candidate. Yet this aircraft, if we accept Freeland's detailed description, was not manmade, or at least did not fit the common catalog of manmade aerial craft. Could the soundless aspect be a "mistake": Freeland only thought that helicopters could be heard up to 8 miles away? Could the UFO have been a helicopter hovering out of hearing range? If so, how do we explain its disappearance? Could it have moved in the interim between the dropping of the binoculars and the raising of them, having blended into the background? That is the only explanation I can conceive.

## METEOR, Continued

fulfilled:

1. The type of the UFO sighting must be such that it can, under no circumstances, be ascribed to a misidentified re-entry or meteor.
2. The temporal correlation of such sighting types with re-entry or meteoritic phenomena must be statistically significant.
3. It must be possible to exclude any natural, causal connection

between both events.

The authors of the aforementioned article speculate that there is an extraterrestrial intelligence with the desire to mask their own operations cunningly and with the necessary sociological insight to accomplish this.

But this would in itself make any test of requirement (2) very difficult or even render it useless, because our hypothetical extraterrestrials would probably be wise enough to limit the extent of their visits during re-entries to a statistically insignificant level.

Regarding requirement (3) it must be mentioned that there is scant evidence that meteoritic falls (and re-entries too?) sometimes cause secondary magnetic and electrical phenomena.<sup>5 6 7</sup>

But no matter whether UFOs correlated with re-entries of satellites or meteoritic falls are regarded as geophysical phenomena or as the manifestations of an extraterrestrial intelligence, it seems that a more extensive and systematic search for such correlations is justified.

### REFERENCES

1. Dan Wright and Harriet Beech: "Re-Entry Re-Examined," in MUFON UFO JOURNAL, November 1984, pp. 5-6
2. H.H. Nininger: *Out of the Sky*, Dover Publications Inc., New York, 1959, p. 32 ff.
3. The most complete report of this event I could find is in the book *Flying Saucers on the Attack* by H.T. Wilkins (Citadel Press, New York, 1954) on page 97. Wilkins however does not give a source for it. In Frank Scully's book *Behind the Flying Saucers* (New York: Henry Holt & Co., 1950) the sighting of a Stockton farmer is shortly mentioned under the same date on page 193. Scully quotes as source "The Omaha Herald". Presumably both reports refer to the same case.
4. Philip J. Klass: *UFOs Explained*, Random House, New York, 1974, pp. 167-174
5. *Ibid.* p. 173
6. On magnetic and electrical phenomena possibly correlated with meteoritic falls see also the various catalogues compiled by William R. Corliss, Box 107, Glen Arm, MD 21057.
7. A very early observation which could fall into this category has been made after the fall of the Dhurmsalla meteorite on 28 July 1860, when lights were seen, some of them "not very high". See *The Books of Charles Fort*, Henry Holt & Co., New York, 1959, page 245-246.



## LETTERS

-By the Readers

**Dear Editor,**

Upon receipt of the February 1985 issue of the MUFON UFO Journal, I was delighted to find the in-depth interview with Dr. J. Allen Hynek. The article was both interesting and informative. Being a member of MUFON and an Associate of C.U.F.O.S., I have the highest respect and esteem for Dr. Hynek and his dedication to trying to find an answer to the UFO enigma. It is persons such as Dr. Hynek and Mr. Walter Andrus that gives credibility to UFOLOGY, and encouragement to all of us who are seeking a solution to the puzzle, and trying to fit together the pieces of information which have been gleaned from the UFO sighting reports, as one would work a jigsaw puzzle.

It would be interesting if you would also conduct an interview with the founder of MUFON, Mr. Walter Andrus, and enlighten your readers on how he came to be interested in the subject of the UFO phenomenon, and how he came to form the Mutual UFO Network, for he, too, has contributed much in his dedication to seeking to resolve the UFO enigma, and forming a network of members working together towards this goal. Perhaps later on, you could consider interviews with others who are leaders in this field.

**Mrs. Shirley Lynch,**  
State Section Director, Georgia

**Dear Editor,**

In the February, 1985 issue of the Journal, Jim McCampbell presented the case for microwave emissions from UFOs. Jim has long championed the analysis of close encounter physical effects as a basis for establishing the reality and nature of these objects, and I have the greatest respect for his work. Nevertheless, I believe that the anecdotal and other evidence indicate instead the presence of low frequency magnetic fields. Two primary reasons present themselves.

First, the anecdotal evidence points to a number of effects explainable only by induction (low frequency) fields. Conversely, I am aware of no effects which can be explained solely by RF (radio frequency) fields such as microwaves.

Oscillating magnetic fields can disturb magnetic compasses. Microwaves can exhibit no such influence. Powerful magnetic fields can cause road signs to vibrate, microwaves cannot. In previous articles (MUFON Journal 194 and 197) the present author has shown that the heating of finger rings and watch bands, and possibly subsurface heating of soil beneath hovering UFOs, is attributable to low frequency magnetic fields. Neither effect can be attributed to microwaves. Similarly, magnetic fields can penetrate the hood of an automobile and induce disruptive voltages in the ignition circuit, causing the engine to labor and stop. The hood, however, forms an effective shield against RF, which would have little effect on the engine even if it could get to it.

Second, as one moves away from a source of microwaves, their intensity decreases as the square of the distance, as it does from any radio transmitter. A powerful source of microwaves would be "heard" for great distances, particularly if airborne. And, there are a lot of receivers on this planet capable of detecting and monitoring its signal. An example of such detectors is military ELINT (Electronic Intelligence). Sadly, there are parts of the world where there are as many ELINT receivers as commercial AM radios. If UFOs emitted microwaves, everyone would know by now.

Conversely, low frequency magnetic fields decrease as the cube of the distance between source and receiver. Because these fields diminish so rapidly, the signal from even a powerful source of such fields would be undetectable within 10 to 20 miles.

When one considers how few receivers exist to "listen" to such signals (what receivers do exist are generally geomagnetic research stations), one can see how such sources could have eluded detection so far.

A famous case frequently cited as an example of microwave emission from UFOs is the 1957 RB47 case. A reconnaissance bomber carrying airborne ELINT tracked UFOs with receivers tuned to 3000 Mhz. Some ufologists have assumed that the objects were emitting this radiation, but since the signals were characteristic of CPS6B air defense radar, it is obvious that the objects were being "painted" by ground radar and merely reflecting this energy.

I have no theory as to the origin of UFO sounds. Aside from Jim's work, the only serious work done on UFO noises that the author is aware of was due to Regan and Allan (1979 MUFON Symposium). This involved the analysis of sound pulses recorded in Bragg Creek, Alberta. Thus there is some evidence that at least some UFO sounds are indeed acoustic. That dogs and cats may respond unusually to UFO noises is, if true, hardly surprising. Most mechanical sources of sound (as opposed to electronic audio equipment) produce sound rich in harmonics which extend well into the ultrasonic region. The hysterical wailing of dogs when an ambulance or fire truck passes is precisely due to this phenomenon.

**Joe Kirk Thomas**  
Los Angeles, California

**Dear Editor,**

After all these years and tears, I had hoped ufology had learned its lesson regarding light phenomena seen high in skies over a wide area. Good examples: that Romanian ship off the coast of Brazil, or the Chinese cases

(continued next page)

## LETTERS, Continued

reported (with illustrations) by Paul Dong a few issues back.

The lesson, which I weary of reiterating to a deliberately deaf audience, is to check out some of the more obvious man-made stimuli before rushing into print with another juicy UFO report. In fact, were such checks made with space experts on the above cases? Not to my knowledge....and I have been congenial and cooperative with other requests, particularly on recent cases in Chile and Argentina.

Do ufologists really want to solve UFO cases? It sure doesn't look that way. I'd expect such an approach from the *National Enquirer*. It's disappointing to see it from MUFON.

**JIM OBERG**  
Dickinson, Texas

**Dear Editor,**

I think you're making an excellent job of the *Journal* — it's got a solid, purposive feel to it. Looking back over my files, it's encouraging to see the *Journal* steadily improving, year by year, from what originally was not a lot better than the newsletters of a dozen different UFO groups, to what is today one of the best of all the journals... With FSR in a very bad way, here in England we don't have anything to compare, though John Rimmer is embarking on a plan to raise *Magonia's* coverage to make at least some kind of replacement for FSR. Meanwhile, over in Belgium, *Inforespace*, once the most 'scientific' of the UFO journals, has had to lower its sights and go from a nicely printed to a tattily typewritten format; and while France's *Lumieres dans la Nuit* keeps doggedly going, Veillith is an old man now, and so are his collaborators, and one wonders if he's making any better provision for the future than Charles Bowen did?

All very sad.... Yours'll soon be the only general UFO journal in existence!

**Hilary Evans**  
London

**Dear Editor,**

No doubt, you wonder what kind of person subscribes to the MUFON UFO JOURNAL. Well, I am neither a skeptic nor a "true believer" on the

subject of UFOs, but one who tries to be broad-minded on this subject. I have never seen a flying saucer, but I have seen strange lights in the sky which I could not explain. About ten years ago, I saw a red light (about the color of a stop light) that hovered in the air for several minutes, then plummeted to the ground. In the position where the light had been I noticed a dim glow, then all of a sudden, I saw a ball of flame which immediately went out. I suspect that someone was playing a prank and that the red light was suspended from a hydrogen-filled balloon. When the flame reached the balloon, it flared up like the Hindenburg, but on a much smaller scale.

More recently, I have seen similar lights in the sky, but the last one just flickered out. If it had taken off like a meteor, I would have suspected it to be a UFO. Incidentally, I am an amateur astronomer, so I do not think everything unusual in the sky to be a UFO. I have talked to people who claimed to have seen UFOs, but I act like a Missourian when I hear these stories.

Yours truly,  
**Leland A. Dolan**  
Houston, Texas

**Dear Editor,**

The April 23, 1985 issue of the *National Examiner*, a dreadful supermarket tabloid, has an article which purports to quote me on the subject of UFO abductions. The background of this unfortunate article is as follows:

A few weeks ago I received a phone call from, I presume, the "John Turner" who assembled the article; I do not remember his name. He asked if I would cooperate with his paper on a UFO piece. I instantly declined, and he asked why. "The context," I explained. I told him I fervently disapproved of this sort of tabloid. "I understand perfectly," he answered, and went on to admit that his publication was sleazy, but that, more or less, "a job is a job." I commiserated.

He then went on to say that he had read my book *Missing Time*, and that he was, himself, interested in the subject of UFO abductions. Then, after saying that this was all "off the record," I

told him that I was looking into a number of new, strong cases. We chatted for a few minutes, and ended our conversation.

Obviously I have been tricked and used, and I have myself to blame for being falsely trusting. When a friend told me about the article I was enraged, particularly so because something a little like this has happened to me before. I noticed that, at the least, the writer does not claim to have personally interviewed me. Much of the wildly garbled material it includes is garnered from *Missing Time* as well as various MUFON Journal pieces I have done, comments by Allen Hynek in *IUR*, and so forth - all "public domain" material - so I have virtually no recourse.

I have learned a lesson. When any of us receives a phone call from any of these "reporters" - say no and hang up instantly! I deeply regret this incident, and apologize to my colleagues for any embarrassment it may have caused them.

Sincerely,  
**Budd Hopkins**  
New York

---

## OTHERS' WORDS, Continued

Paul Trent in 1950, as well as the Great Falls, Montana, UFO film taken by Nicholas Marina, also in 1950.

Was there really an advanced civilization on the planet Mars some 500,000 years ago? It certainly looks as though there might have been, judging by the evidence contained in **PRELIMINARY REPORT OF THE INDEPENDENT MARS INVESTIGATION TEAM: NEW EVIDENCE OF PRIOR HABITATION?** The report has 24 pages of text and 16 pages of photographs (including computer enhancements) taken by the Viking probes in orbit around Mars. What seems to be a human (or humanoid) face is clearly visible, as well as very large pyramidal structures and formations which suggest ruined cities. The paper is available for \$10.00 from its author, Richard C. Hoagland, at: 331 62nd Street - Oakland, CA 94618. Highly recommended.

# STARS & PLANETS

By Walter N. Webb

JUNE 1985

## Bright Planets (Evening Sky):

Saturn, still retrograding westward in Libra, is now the lone planet in the evening sky until Jupiter rises. The yellow ringed world can be seen low in the SE at dusk some 18° to the upper right of the dimmer red star Antares. The nearly full moon is below the planet on June 1.

Jupiter, brightening to magnitude -2.2 in Capricornus, rises in the east around 11:30 PM in midmonth and is the brightest planet in the sky until Venus rises. This largest world of the solar system commences moving westward on the 5th—an effect due to our faster-moving earth overtaking Saturn. (The illusion is similar to that created when one car passes another on the highway.)

## Bright Planets (Morning Sky):

Venus rises north of east just before 3 AM in midmonth. It reaches a point farthest west of the sun on the 12th. While this brilliant white planet shines in the east, Jupiter (five times fainter) dominates the southern sky. The crescent moon will lie in the vicinity of Venus from June 13 to 15; on the 14th the planet passes only 2° south of our satellite—a nice sight. The Soviet's Vega 1 and 2 spacecraft drop two landers on Venus on the 14th and 18th.

Jupiter is low in the south at dawn. The moon appears below this giant world on the 7th.

Saturn sets south of west about 3:30 AM in midmonth.

## Moon Phases:

Full moon--June 2  
Last quarter--June 10  
New moon--June 18  
First quarter--June 25



## The Stars:

Heralding the approach of summer, the Summer Triangle of Vega, Deneb, and Altair greets the observer in the eastern sky. Even though blue-white Vega looks to the naked eye as if it is the brightest star of the season, actually orange-tinted Arcturus (in Bootes) located high in the SW outshines it by one-tenth magnitude. Red Antares (in Scorpius) moves low above the southern horizon, while Regulus (in Leo) nears the western horizon.

Nearly overhead after twilight ends can be found a four-sided wedge of faint stars called the Keystone (in Hercules). Look for a tiny fuzzy "star" along the right side of the wedge—in reality the Great Hercules Cluster composed of thousands of stars in a vast globular cluster. Telescopes of increasing size resolve the patch into more and more stars.

Be aware of a UFO culprit, the bright star of Capella, which skirts the northern horizon at this time of the year.

## MESSAGE, Continued

in his possession from the site and can obtain the plaster casts made of the imprints at the landing site. This case continues to unfold, but still needs an official endorsement from the U.S. Air Force and the United States Government.

## IN OTHERS' WORDS

-By Lucius Farish

A summary of so-called "monsters from outer space" reports appears in the January 22 issue of **NATIONAL ENQUIRER**. The cases, taken from Daniel Cohen's book, **ENCYCLOPEDIA OF MONSTERS**, include the Flatwoods, WV creature of 1952, the Hopkinsville, KY "little men" of 1955 and others. UFOs and alleged appearances of the Virgin Mary are combined in the **ENQUIRER's** March 19 issue. The phenomena have occurred in the Spanish town of El Escorial since 1981, according to numerous reports.

The controversy over an alleged crashed UFO in Puget Sound, Washington State, is explored in the January 29 issue of **STAR**. Dr. Bruce Maccabee and other UFO researchers have been investigating the reports since a circular glowing object was seen to enter the Sound on July 27, 1984.

The February issue of **OMNI** devotes several pages to yet another interview with J. Allen Hynek. It has been truly said that if you've read one Hynek interview, you've read them all, so this can only be recommended for insomniacs. A very interesting UFO photo from Canada is discussed in the "Anti-Matter/UFO Update" section of March **OMNI**. This issue also contains an article on the alleged ancient constructions on the planet Mars, a subject of considerable interest to many UFO researchers.

**FATE's** March issue has an article by Alvin H. Lawson, outlining his theory that UFO abductions can be explained as "birth memories." In the April issue of **FATE**, Dr. Bruce Maccabee's continuing series of articles examines the controversial UFO photos taken by

(continued on page 17)

## MESSAGE, Continued

and slide box. Please order these slide sets directly from Dan Wright, 1502 Marquette, Lansing, MI, 48906. These visual aids will provide valuable program material for our members when making public presentations. This project fulfills an essential need.

\*\*\*

Since its inception in 1969, the Mutual UFO Network has never had an effective program for our budding ufologists who are 17 years of age and under. Teenagers of that era have since been elevated to leadership roles as they matured and became the backbone of ufology for today. However, what is even more important is the fact that these young men and women are our future ufologists in the continuing quest to resolve the UFO enigma. These young people have grown-up in the space-age with its sophisticated technology, therefore their minds are far more receptive to seeking answers to the mystery and challenge of the UFO phenomenon.

**Shirley Fox**, a State Section Director in Florida, has already started working with young people in the Ft. Myers area. **Ken Wisnefski**, a young man in Asbury, N.J., has organized a group of his friends and named their team appropriately "The Future UFO Investigators." With adult guidance, **George Gregg, Jr.** (age 15) has volunteered to handle MUFON headquarters correspondence with this emerging body of interested young people. In his first assignment, he has responded to questions posed by Ken Wisnefski. George will be working directly with the International Director in his new assignment and will thus have the facilities and services of the administrative office for support. Junior investigators may write to him at 201 Coventry, Seguin, TX 78155-4099 or to the MUFON office. We hope to present a detailed plan for the operation, titles, privileges, ID card identification, etc. for this new and important committee within MUFON at the 1985 Annual Corporate Meeting in St. Louis. In the meantime, we invite all members 17 years of age or under to write to George signifying their interests in establishing such a committee.

\*\*\*

It has been brought to our attention that at least one person has been writing to government agencies under the Freedom of Information Act (FOIA) demanding information and threatened lawsuits if the agency does not comply. We cannot and will not forbid anyone from making FOIA requests within the legal limitations of the law. However, we become very concerned when they identify themselves as a MUFON member, hoping to imply that they are speaking for and represent the Mutual UFO Network. Considering the large number of officers in MUFON, it is very difficult to specify who has the authority to write letters on behalf of MUFON. However, in order to preserve the fine reputation that we have earned, we will specify by organizational level who is authorized to write letters speaking on behalf of MUFON at the Annual Corporate Meeting. In the meantime, members should use discretion if they identify their capacity in MUFON by plainly stating that he/she is not an officer or spokesman for the organization, but is only writing in the capacity of a private citizen.

We do not want to discourage anyone from utilizing the Freedom of Information Act (FOIA) or writing to public governmental officials, even up to the President of the United States, if they are seeking UFO information or public support, provided that it is done in good taste and with proper respect to our elected officials in city, county, state or U.S. governmental bodies.

\*\*\*

Volume 1 Number 2 of the Compufon Network Newsletter was published on April 15, 1985 and mailed to all current Compufon members by **Michael D. Hart**, Director. An instruction sheet for using the Compufon Network was prepared on 4/12/85. If you have computer facilities, a modem and would like to participate in this service, please write to Michael D. Hart, The Compufon Network, 803 5th Place S.E., Duvall, WA 98019. Mike will provide you with the instructions, password, system ID, etc.

\*\*\*

The Central Regional Director on the MUFON Board of Directors is to be

elected to fill the expired term of Charles Tucker by a mail vote of the members in the states encompassing the Central Region of the U.S.A. Since we received only one qualified nomination for this position as of April 15, 1985, we would like to dispense with the cost of a mail ballot as prescribed in the MUFON Bylaws. **Dan Wright**, presently the State Director for Michigan, was the only candidate nominated. His name will be submitted to the members attending the Annual MUFON Corporate Meeting from the Central Region for their vote. We want to thank **Charles Tucker** for having served in this capacity after being elected in Dayton, Ohio in 1978.

**Ray Boeche**, State Director for Nebraska, has been meeting with the U.S. Senator from Nebraska, the Honorable **J. James Exon**, to interest him in exploring the Rendlesham Forest Case further within the Senate Armed Forces Committee, of which he is a member along with **Barry Goldwater** (Arizona) and the entire U.S. Senate. Each State Director is hereby authorized to write to each of your two U.S. Senators advising them of pertinent details by letter and including xerox copies of articles from the MUFON UFO JOURNAL where appropriate, soliciting their help in officially exposing this case to the American public. If Senators start asking each other about the Rendlesham Forest episode based upon "letters from home," it is conceivable that they could take positive action.

\*\*\*

During the first part of April in a telephone call by Ray Boeche, Colonel **Charles I. Halt** verbally agreed to substantiate his investigation, the audio tape, photographs, plaster casts, etc. to Senator Exon if he was personally asked by the Senator. A U.S.A.F. officer at the scene (name in MUFON file), who drove General Williams from the site back to Bentwaters AFB, stated that the General had a canister of film in his possession. The film was flown from Bentwaters to Ramstein AFB in West Germany for processing. Colonel Halt stated that he still has soil samples

(continued on page 18)

# DIRECTOR'S MESSAGE

by  
Walt Andrus

The MUFON 1985 UFO Symposium will be held at the Chase Hotel in St. Louis, Missouri on June 28, 29 and 30. The speakers will address the theme for this year's Symposium — "UFO: The Burden of Proof." The speakers and their titles are **Marge Christensen**, "Shifting the Burden of Proof"; **George D. Fawcett**, "What We Have Learned from UFO Repetitions"; **Leonard H. Stringfield**, "The Fatal Encounter at Ft. Dix-McGuire: A Case Study; Status Report IV"; **Budd Hopkins**, "The Evidence Supporting UFO Abduction Reports"; **John F. Schuessler**, "The Medical Evidence in UFO Cases"; **Ted Phillips**, "Physical Trace Landing Reports: The Case for UFOs"; **David F. Webb**, "The Influence of Hypnosis in the Investigation of Abduction Cases"; **William L. Moore**, "Crashed Saucers: Evidence in Search of Proof"; **Stanton T. Friedman**, "Flying Saucers, Noisy Negativists and Truth"; and **Peter A. Gersten**, "Proof Beyond a Reasonable Doubt."

Advanced reservations for all four sessions is \$25.00 prior to June 21, 1985. Checks should be made payable to "UFO Study Group of Greater St. Louis" and mailed to **Mrs. Helen C. Hanke**, 4024 90th Ave., Florissant, Mo, 63034. The price at the door for all sessions is \$28.00. The price for each of the four sessions is \$7.50. Hotel reservations may be made by contacting the Reservation Manager, Chase Hotel, 212 North Kingshighway, St. Louis, MO 63108 or by telephone (314) 361-2500. Fifty rooms are being held for attendees, but reservations should be made no later than 30 days prior to the Symposium to insure accommodations. Room rates are \$60.00 per day for a single or double, \$70.00 for 3 persons and \$80.00 for 4 persons. There is no charge for children under 18 years of age. If you are unable to obtain reservations at the Chase Hotel, please contact Helen Hanke or

Barbara Becker at P.O. Box 3283, St. Louis, MO 63130.

On Friday evening, **Ken McLean**, State Director for Wyoming will speak on public education to a special meeting being chaired by Mrs. Marge Christensen for State Directors, Assistant State Directors, State Public Relations Directors and the members of MUFON's Public Information and Public Education Committee (P.I.P.E.) On Sunday morning, June 30th, the Annual MUFON Corporate Meeting will be held from 9 a.m. to noon. State Directors and Committee Heads should be prepared to submit their written and oral activity reports. Election of officers will be conducted. As the host committee has sang so often — "Meet Me in St. Louis."

The **MUFON 1985 UFO Symposium Proceedings** will be available at the St. Louis symposium for \$10.00 and by mail after July 1, 1985 for \$11.50 which includes postage and handling.

\*\*\*

**Anthony A. Neugebauer**, a Christian Minister in Seguin, Texas, has been appointed the State Section Director for Guadalupe and Caldwell Counties replacing Alvin L. Barrier, M.D. On April 18th, he was elected President of the newly formed Guadalupe Valley UFO Study Group and was the program speaker at the March meeting. **William F. Hassel**, Ph.D., State Director for Southern California, has appointed **Mark Toto** in Irving, Calif. to be the State Section Director for Orange County, replacing Willard D. Nelson who retired from the aerospace industry and moved to Olympia, Wash. **George Fawcett** has approved the selection of **Ronald A. Collins** to be the State Section Director for Cumberland and Harnet Counties in North Carolina. Mr. Collins 6 years of experience in the U.S.A.F. in intelligence and security will be an asset to his work in MUFON.

\*\*\*

**R. Leo Sprinkle**, Ph.D. and **Douglas G. Tipton** have announced that the "6th Rocky Mountain Conference on UFO Investigation" will be held July 11-13, 1985 at the University of Wyoming in Laramie. Reduced registration fees are in effect prior to June 7 at \$20.00 for a single or \$30.00 for a couple. Housing is available on-campus in the residence hall. A registration form and more details may be obtained by writing to Conferences and Institutes, P.O. Box 3972, University Station, Laramie, WY 82071-3972.

On March 31, 1985, a new publication and organization was announced with the publishing of **FOCUS**, the monthly newsletter of the Fair-Witness Project, Inc., 4219 W. Olive St., Suite 247, Burbank, CA 91505; telephone (818) 506-8365 by their editor, and Vice-President, **Evan J. Hayworth**. Other officers are **William L. Moore**, President; **David J. Branch**, Treasurer; **Otto A. Steen**, Correspondence Secretary; **Stanton T. Friedman**, Atlantic Regional Director; **Nic Magnuson**, Midwest Regional Director; and **Kal K. Korff**, Special Consultant, in the biographical sketches for their officers, William L. Moore is listed as "California State Director for the Mutual UFO Network." Obviously, this is an error and should be deleted from their literature. Before moving to Burbank, Calif., Bill was a MUFON State Section Director in Arizona.

\*\*\*

This is a correction due to a misunderstanding concerning the 35mm slide lectures produced by **Dan Wright** for UFO public education programs. There is only one program, but it is available in two lengths. The set of 50 slides will cost \$25.00, while the set of 100 slides will sell for \$45.00, which includes printed commentary, slides

(continued on page 19)

# MUFON UFO JOURNAL

NUMBER 206

JUNE 1985

Founded 1967

OFFICIAL PUBLICATION OF



MUTUAL UFO NETWORK, INC.

\$1.50

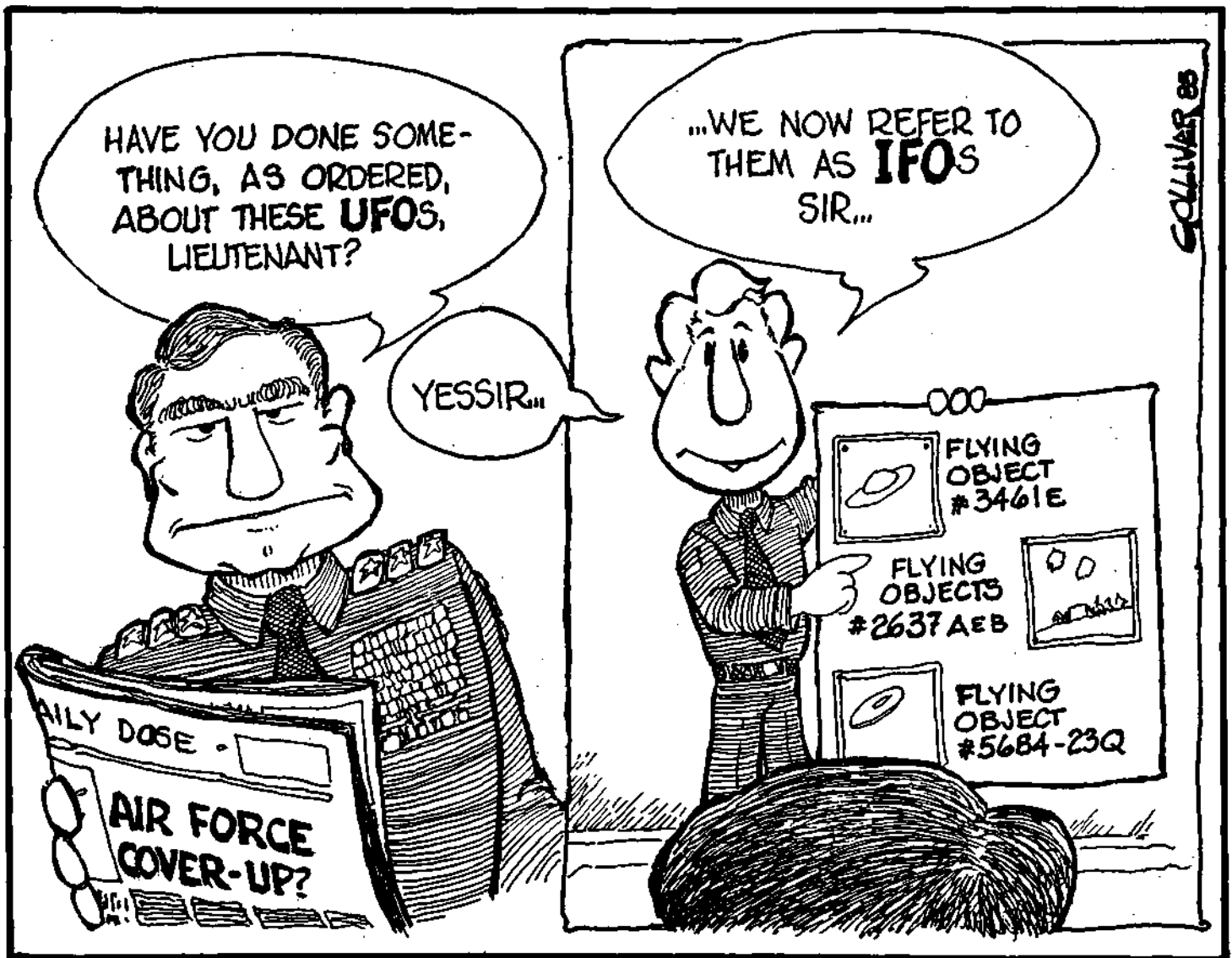

**MUFON UFO JOURNAL**  
 (USPS 002-970)  
 (ISSN 0270-6822)  
 103 Oldtowne Rd.  
 Seguin, Texas 78155-4099

**DENNIS W. STACY**  
 Editor

**WALTER H. ANDRUS, JR.**  
 International Director and  
 Associate Editor

**THOMAS P. DEULEY**  
 Art Director

**MILDRED BIESELE**  
 Contributing Editor

**ANN DRUFFEL**  
 Contributing Editor

**TED BLOECHER**  
**DAVE WEBB**  
 Co-Chairmen,  
 Humanoid Study Group

**PAUL CERNY**  
 Promotion/Publicity

**MARGE CHRISTENSEN**  
 Public Relations

**REV. BARRY DOWNING**  
 Religion and UFOs

**LUCIUS FARISH**  
 Books/Periodicals/History

**ROSETTA HOLMES**  
 Promotion/Publicity

**GREG LONG**  
 Staff Writer

**SIMONE MENDEZ**  
 Staff Artist

**TED PHILLIPS**  
 Landing Trace Cases

**JOHN F. SCHUESSLER**  
 Medical Cases

**LEONARD STRINGFIELD**  
 UFO Crash/Retrieval

**WALTER N. WEBB**  
 Astronomy

**NORMA E. SHORT**  
**DWIGHT CONNELLY**

**DENNIS HAUCK**

**RICHARD H. HALL**

**ROBERT V. PRATT**

Editor/Publishers Emeritus

The MUFON UFO JOURNAL is published by the Mutual UFO Network, Inc., Seguin, Texas. Membership/Subscription rates: \$15.00 per year in the U.S.A.; \$16.00 foreign in U.S. funds. Copyright 1985 by the Mutual UFO Network. Second class postage paid at Seguin, Texas. POSTMASTER: Send form 3579 to advise change of address to The MUFON UFO JOURNAL, 103 Oldtowne Rd., Seguin, Texas 78155.

# FROM THE EDITOR

This issue welcomes back a former editor of the Journal, Richard Hall, with some pungent points about the current state of affairs in ufology. Jennie Zeidman gives us an on-the-spot impression of her recent visit to Rendlesham Forest, and Stan Gordon looks at current Pennsylvania reports. Philip Mantle, Overseas Liaison Officer for the Yorkshire (England) UFO Society, re-opens the case for the extraterrestrial hypothesis, and Francis Ridge, MUFON State-Section Director for Indiana, reviews NICAP's *The UFO Evidence*, 20 years after its original publication. Our cover is by west Texas cartoonist, Gary Oliver, pen name "Golliver". We hope to see more of his work in the Journal, too.

July will be an issue devoted exclusively to the recently declassified Air Intelligence Report of December 10, 1948, "Analysis of Flying Objects in the U.S." The August or September issue of the Journal will carry complete coverage of the St. Louis Symposium, my own interview with Richard Haines, and the regular features and departments that make the MUFON Journal a recognized world-leader in the study and reporting of unidentified aerial phenomena.

Obviously we think the Journal deserves your continued support. Why not take a small portion of your tax-refund and buy your Senator or Congressman, state or federal, a year's subscription beginning with the important July Air Intelligence Report issue? Since we're a non-profit organization, you'll be able to deduct the subscription from this year's taxes, too!

## In this issue

RENDELSHAM RE-VISITED, by Jennie Zeidman .....	3
PENNSYLVANIA REPORTS, by Stan Gordon .....	5
IN OTHERS' WORDS, by Lucius Farish .....	8
THE CASE FOR E-T CONTACT, by Philip Mantle .....	9
BLUEPRINT FOR PROGRESS, by Richard Hall .....	12
THE UFO EVIDENCE: 20 Years After, by Francis Ridge .....	14
PROCEEDINGS DEDICATION, by Walt Andrus .....	15
LETTERS .....	16
THE NIGHT SKY, by Walter Webb .....	18
DIRECTOR'S MESSAGE, by Walt Andrus .....	20
COVER, by Golliver	

The Mutual UFO Network, Inc. is exempt from Federal Income Tax under Section 501(c)(3) of the Internal Revenue Code. MUFON is a publicly supported organization of the type described in Section 509(a)(2). Donors may deduct contributions from their Federal income tax. In addition, bequests, legacies, devises, transfers, or gifts are deductible for Federal estate and gift tax purposes if they meet the applicable provisions of Sections 2055, 2106, and 2522 of the code.

The contents of the MUFON UFO JOURNAL are determined by the editor, and do not necessarily represent the official position of MUFON. Opinions of contributors are their own, and do not necessarily reflect those of the editor, the staff, or MUFON. Articles may be forwarded directly to MUFON. Responses to published articles may be in a Letter to the Editor (up to about 400 words) or in a short article (up to about 2,000 words). Thereafter, the "50% rule" is applied: the article author may reply but will be allowed half the wordage used in the response; the responder may answer the author but will be allowed half the wordage used in the author's reply, etc. All submissions are subject to editing for style, clarity, and conciseness. Permission is hereby granted to quote from this issue provided not more than 200 words are quoted from any one article, the author of the article is given credit, and the statement "Copyright 1985 by the Mutual UFO Network, 103 Oldtowne Rd., Seguin, Texas" is included.

# RENDLESHAM RE-VISITED

By Jennie Zeidman

By now, ufologists and ufobuffs alike are familiar with the Rendlesham Forest Affair. The night of December 27, 1980, a UFO allegedly crash-landed in a forest near a U.S. Air Base (RAF Woodbridge) in Suffolk, England. U.S. personnel went to the site, and the Base Commander communicated with three alien entities during the several hours the triangular-shaped craft was grounded for repairs. Two nights later, at the same site, the Deputy Base Commander (Lt. Col. Charles Halt) and others were treated to a repeat visit by strange pulsing lights. Halt made a "real-time" audio tape of that event.

The case "belongs" to Jenny Randles, Dot Street, and Brenda Butler. Dot and Brenda, relatively inexperienced, non-scientifically oriented UFO investigators (Dot, BUFORA; Brenda, independent) did most of the leg work, while Jenny, internationally respected Chief of Investigations for BUFORA, was their mentor, coaching from the sidelines at her home in Warrington, near Liverpool. Their book, *Sky Crash*,<sup>1</sup> is a convoluted chronology of their investigation which creates more mysteries than it solves. It concerns itself not so much with their findings (which were few) but with their great difficulties with witnesses and government agencies. The contention is that there exists a gigantic conspiratorial coverup on the case.

## VISIT

I spent all day April 9, 1985, with Dot Street—in Woodbridge village, in Rendlesham Forest, and at the site, and the following Saturday evening in London—with Dot, Jenny Randles, Peter Warrington, Hilary Evans, Tomothy Good, et al, at a BUFORA meeting where the topic was British Government cover-up, and the speaker was Ralph Noyes, a former Air Ministry Intelligence Officer. Upon his



RALPH NOYES and JENNY RANGLES

—Photo by Jennie Zeidman

## HALT'S ROLE

I consider the primary witness to be Col. Halt. He is admittedly an eyewitness, and it is he who is identified as the originator of two of the four documents (that I am aware of) on the case.

As a point of view, the four documents are:

- Halt's memo to the Ministry of Defense, dated 1/31/81
- Halt's audio tape, allegedly made in "real-time," 12/29/80
- MOD memo, lightly censored, undated, leaked to Jenny Randles
- MOD letter to Jenny re: 12/27 events, dated April 13, 1983.

Once a document (written, tape, photo, whatever) is introduced into a scenario, it becomes an "exhibit" of

retirement in 1977, Noyes was head of DS-8, the office "in charge of UFO matters." Jenny said having Ralph Noyes lecture BUFORA was equivalent to having Ed Ruppelt lecture CUFOS.

None of this makes me an expert on the RFA (Rendlesham Forest Affair); however I believe it has given me a perspective on the case that I haven't seen elsewhere, and I'd like to make a few comments to that effect. If nothing more, the moles among us may enjoy a few hearty laughs.<sup>2</sup>

In our "usual" cases, we (the investigators) interrogate witnesses who are cooperative to the best of their abilities, i.e., they're "on our side," they are truly puzzled, and they are looking to us for help. In the RFA (as presented in *Sky Crash*), just the opposite is true: the primary witness has done his best to impede the investigation and confuse, mislead, and even tease the investigators.

(continued next page)



## DOT STREET

-Photo by Jennie Zeidman

### RENDELSHAM, Continued

hard evidence--whether true or false--and it cannot be disregarded, for (paranoia hats on, everyone!) if false, it nevertheless has been created and disseminated for a purpose. The person indentified as responsible for the creation of that document has put himself on the line, whether of his own volition or on orders, and he must forever be associated with that document, regardless of its legitimacy.

Col. Halt has certainly put himself on the line.

But not all the problems with the case revolve around Col. Halt. The hard facts are that of the few alleged eye-witnesses, much of their testimony has been surrendered reluctantly, and none of their testimony (in the book) has been offered verbatim. We know that Dot and Brenda had a tape recorder, yet we are offered no question and answer transcripts or even dialogue--only generalities, sometimes second-and-third generation ones, at that (Paul Begg



## ZEIDMAN IN RENDELSHAM FOREST

—Photo by Dot Street

told Jenny that he had heard, etc.....).

*The information therefore becomes anecdotal, not testimonial.* Fine nuances and intricacies of tone and language are lost. Granted, we are not in a court of law, where verbiage of this sort is inadmissible. But we are in a court of science, where any and every shred of subjectivity or generality muddies our case. And many a court case has been lost not because that side was wrong, but because it was ill-prepared. The testimony did not convince the jurors. Jurors become discouraged and negatively disposed when offered a can of worms.

Of course *Sky Crash* was constructed anecdotally for wider reader appeal, and I respect that choice of treatment by the authors. It was not intended as a technical report. And that's too bad, because I suspect that if scraped down to the bare bones, rich marrow could yet be retrieved. Going through the book--and the investigators' original tapes and notes--line by line, and constructing flow charts, could be of value in sorting

things out--a method of discovering consistencies and discrepancies (and just which character did what, and with what, to whom!).

### CAUTION

But caution is advised. Some of the material is simply not true--and not necessarily from witness testimony but from false premises put forward by the authors. E.g.; the morning after our arrival at Woodbridge, I asked my husband's liaison, Sgt. Vergil Yarborough, how long he'd been on base. "Five years come June," he replied. "Gosh," I said (batting eyelashes), "that's a long time! Why, you must have been here when the UFO landed!" "Yeah," He said. "Did you see it?" I asked, "Do you know anything about it?" "No," he replied, "I just heard about it from other fellows. Best thing, you get the book. There's a book out on it--it's for sale at the base bookstore--it'll tell you all about it."

(continued on page 15)

# PENNSYLVANIA REPORTS

By Stan Gordon

It was 6:10 AM on the morning of January 2, 1985. Jerry Murtha\* and Tom Mench\*, ages 12 and 13, had gotten up early to check their game traps before going to school.

The sun was just beginning to rise at Jamestown, a rural community located in Lebanon County. The local sky conditions were cloudy with some fog. Jerry and Tom were on the way over to the ravine where they had their traps set when they heard a dog howling from that area. They began to hurry, thinking that the dog must have been caught in one of the traps along the creek. They checked them out and found them empty.

## GLOWING EYES

After spending some time in the area they were just about to return home, when in the distance they noticed 3 sets of glowing eyes. Assuming that they belonged to some type of game they were familiar with, they began to move in that direction.

It was then that Jerry looked up to observe a strange object, which he pointed out to his friend. The two boys laid down on the ground and watched the object as it moved from southwest towards the northeast. The object was described as being oval in shape, metallic gray in color and having a series of lights flashing along its middle edge. The object was estimated to be about 15 feet in diameter, and about 200 feet above the ground. As the boys watched, the object moved very slowly, then stopped and hovered. A low humming sound could be heard as the object began to slowly move again toward a grove of pine trees.

The object then stopped over the pine grove, and from the bottom front section, a bright ball of yellow light about 4 feet in diameter was emitted. This yellow sphere slowly descended towards the top of the tree line, and went down behind the trees, which



—Illustration by Jack Stoner

blocked the sphere from view, but gave the boys the impression that it was going to land.

A short time after the ball disappeared from sight, the main object began to move off in a slow, controlled manner, until it could no longer be seen. The sighting encounter lasted about 5 minutes. Both boys were quite disturbed, and ran home to tell their parents about what they had seen. After discussing the incident, the two boys decided to go back to the area, not only to see if they could again see the object, but to check to see if a skunk they had shot that morning was still alive.

## FIGURE SEEN

They were about half way towards the ravine, when they noticed the silhouette of a man that seemed to have a very tall stature and large build, run through the ravine across the road from them. They assumed that whoever it was might have been raiding their traps.

The sighting occurred about 1,000 yards from a high-tension power

transmission tower, but electrical lines from the tower were close to the vicinity where the larger object was observed. PASU investigator Jack Vogel interviewed the boys and their families, and found them to be sincere and concerned over the incident. They are not publicity seekers and are not UFO buffs.

A search of the area where the ball was seen descending did not turn up any evidence on the ground. However, two pine trees which the sphere descended over were found to have had the tops cleanly sheared off about 15 to 18 feet in height. No burn marks were apparent.

PASU is also investigating another daylight UFO sighting which occurred the next day about 30 miles Northwest of Jonestown at Shamokin. These sightings are among a wave of incidents which have been reported through the first two months of 1985 across Pennsylvania.

\*Indicates a pseudonym for the actual witness. It has been my policy not to use the name of actual observers in my articles unless the actual name has already been used in press coverage.

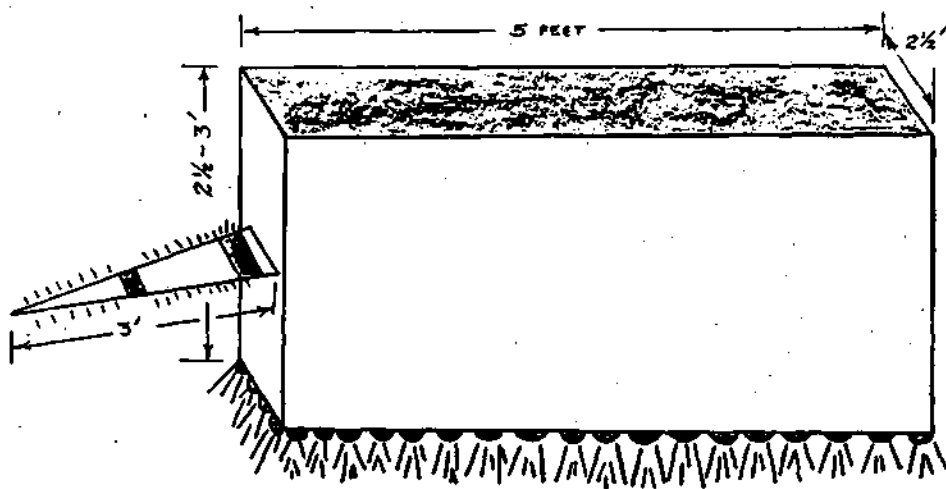

Multiple Bright Lights

—Illustration by Jack Stoner

On the night of October 14, 1984, numerous residents of Pennsylvania reported sightings of Unidentified Flying Objects from many sections of the state. The reports began to come in to the PASU Pa. UFO Hotline number at about 9 PM when observers in Blair County were reporting bright flashing lights and a red ball that streaked vertically into the sky. At about 9:30 PM, a woman near Vail in Blair County, observed a large torpedo-shaped object that appeared to pass low over the field. The object which made no sound, appeared to coincide with electrical interference reported on the television by the witness's family. A short time after the object passed over, a strong sulphur smell was reported in the area.

### GREEN FIREBALL

The majority of reports received on this night were observations of a bright green fireball with a tail, that streaked across the state from Northwest to Southeast. Initial information indicated the observed object was likely a bolide-type meteor. The National UFO Reporting Center in Seattle, Washington, also received numerous reports from other states indicating that the object which had been reported at approximately 9:50 PM had covered a large geographical area.

PASU contacted the Space Center with NORAD, located in Cheyenne Mountain, to see if any re-

entry of space debris could account for the reports. NORAD could not at this time find any such correlation.

The most unusual UFO incident occurring on this night was reported by a woman who lives near Smethport in McKean County. The woman, who wishes to remain anonymous (this information on file with MUFON), did not report the incident to PASU until October 20th, after becoming fearful that the object she had seen at close range may have affected her health.

It is important for serious UFO researchers to look into each UFO report as a separate incident. It would have been very easy to dismiss this case as another sighting of the bolide since the time and location correlated closely with those reports. A more detailed study of the event seems to rule out this possibility.

It was 9:55 PM, and Mrs. X had just taken her poodle outside for their nightly stroll. She was standing just outside the backdoor, when she noticed flashes of bright light on the ground. She assumed that the 100 watt bulb located at the corner of the house was going bad. She stepped away from the house so that she could see where the light was landing, and soon realized that nothing was wrong with the bulb.

### BOX- SHAPE

As she glanced upwards toward the roof, a strange illuminated object floated slowly over the edge of the roof

and very close to it without touching it. The witness watched as the object dropped from the roof and moved lower toward a brook below where the witness was standing. Mrs. X was higher in elevation than the object was, and could see the top of the object at this point. She described the object as being shaped like an oblong box, solid in appearance, and about 5 feet long, 2½ to 3 feet high, and about 2½ feet wide. The side of the object was fluorescent appearing, but not very bright. From the center of the back of the object was a tail-like projection about 3 feet long. This tail did not give the appearance of burning like fire, but was also fluorescent in appearance.

This tail-like appendage was about 2½ inches wide and tapered down to about ½ inch. About 5 inches from the object, the appendage had a dark space of 3 or 4 inches, then it was illuminated for several inches, then there was another dark space, then it was illuminated to the end of the tail. The bottom of the object was covered with numerous bright white lights that did not flash or blink. The witness had the feeling "as if it was taking pictures."

The object, which made no sound, was first observed approximately 25 feet above the ground. It then slowly moved in a bat-like manner down towards a ditch until it was about 15 feet above the ground. Mrs. X thought that the tail appendage would drop into the ditch, but it continued to move on in a controlled manner, toward a hill behind the house. The object then rose in altitude to about 400 feet as it passed over a group of trees and could no longer be seen.

### MANUEVERS

The witness awaited the sound of a crash, but nothing was heard. The object as it moved around the area of the house, missed two TV antennas, a high brick chimney, a large Canadian spruce tree, a 30-foot pine tree, and 6 large Colorado spruce trees growing all around the house except in the back.

About 75 feet in front of the house is the electric supply line for the witness's home and that of her

(continued next page)

## PENNSYLVANIA, Continued

neighbors. About 500 feet in back of the house, and up the hill where the object moved towards, is a high-tension power line. The object, which moved towards the Southeast, was observed for less than a minute.

### HEALTH EFFECTS

The next morning Mrs. X awoke with a severe headache and sore throat. The headache persisted day and night for two weeks after the incident. It was also noted at the location where the object had passed over the roof that the red paint and asphalt was burned off.

Mrs. X also noticed that a strange black soot-like material covered floors in various rooms of her home. As she began to clean it up, she complained that when she touched it, it would sting her hands. After handling the material, Mrs. X reported that her hands and thumb cracked open which she covered with a band aid.

Several days after the incident, the daughter of Mrs. X came to visit. It was at this time the UFO encounter and the soot-like material were discussed. The daughter asked her mother what she had worn the night of the encounter and it was determined it was a heavy black dress which had been hanging in the clothes closet since the night of the incident.

### SOOTY RESIDUE

A white sheet was placed on the outside porch and the dress laid on it. The black soot fell from the dress, which seemed full of the substance. Mrs. X feels this residue fell from the object onto herself and the dog. She has never seen this type of material around her property.

Even though we had corresponded with the witness several times since she and her family made the report to us, we did not receive the dress and sheet with the residue until January 26, 1985, when a certified package was received from Mrs. X.

A PASU consultant examined the material on January 28th. His report indicated that the material was examined on an optical zoom

microscope at low power and on a scanning electron microscope with X-Ray analyzing capabilities. A series of scanning electron microscope photographs were taken at different powers.

### ANALYZED

The original structure of the material was that of a square grid and has an extremely smooth surface. The color of the material samples range from black, through brown, through tan. The material is somewhat transparent at the edges.

The X-Ray analyzer can detect elements except hydrogen. The material contains only carbon, and probably hydrogen. No other elements could be detected (0.5% detectability).

The analyst's conclusion is that the material is biological in nature, and should be examined more thoroughly by a biologist. Samples of the residue have been sent to MUFON for further study by Burt Monroe, Jr. Ph.D., Consultant in Biology.

In conclusion, this UFO incident will continue under investigation. The close proximity of the object to the witness, the unusual shape of the object and the apparent controlled movement, seem to indicate that something unusual did indeed occur. How the residue relates to this observation is open for speculation at this time.

---

Mr. Robinson and his sister Mrs. Jackson\*, both retired, live near the community of Level Green, Pennsylvania, in Westmoreland County. It was December 31, 1984, and the couple had just sat down in their comfortable living room, to watch the evening news.

### TWO TAPS

About 6:10 AM, both parties heard two loud taps in succession against the living room window which faces the front porch. It was unusually warm and pleasant for that time of year, and even though it was dark, the drapes at the front window were drawn back.

Immediately after hearing the taps, Mr. Robinson observed a strange object moving slowly to the right, directly in front of the window. Mr. Robinson who was sitting only 6 feet away, jumped up and ran over to the window and observed the object as it turned sideways and rose up in the air. The object passed within inches under the electric supply line which connects both Mr. Robinson's and his neighbor's home. The object continued to rise as if it was going to move over the roof, but this was blocked from view from where Mr. Robinson was looking.

### "EYE"

The object when first seen in the window appeared to be facing toward the observers. It was described as being spherical in shape, and a little larger than a basketball in diameter. The main object was a bright red color, but did not glow or appear illuminated.

There were two dark lines that appeared either black or dark blue in color, which seemed to extend from the center of the object in a V-like configuration to the top edge. In the center of this V-shaped area was a dark dot the same color as the two lines. The dot was about an inch in diameter and gave the impression "of an eye."

When Mr. Robinson looked out the window at the object, he saw it turn before it began to ascend towards the roof. The back of the object was of the same red color; however there were two beams of bright white light about one inch in thickness and about 16 inches long, that extended out from the object. These beams originated at the center of the back side of the object and seemed to relate to the V-configuration on the opposite side. The light from the beams did not appear to show any reflecting light on the surrounding area, and white sparks could be seen around both of the beams. The object appeared to be pulled in the direction of these two light sources.

### MORE TAPS

After Mr. Robinson saw the object

(continued next page)

the first time through the window, he turned on the porch light and went outside to look but nothing was seen. He turned out the light, went to sit down in his chair, and within seconds two more taps were heard at the window again. The object once again moved slowly directly in front of the window and once again was seen to go up towards the roof and out of sight. This time both Mr. Robinson and Mrs. Jackson saw the object. Mrs. Jackson had heard the taps at the window both times, but only observed the object the second time. After the second sighting, Mr. Robinson turned on both the front porch light as well as the back light, and walked all around the yard trying to see where the object had gone. It was never seen again.

Mrs. Jackson told her brother what she had seen, but he didn't discuss what he had observed with her until two days later, since she was at home by herself quite often and he did not want to frighten her. The object made no sound, and no unusual interference was noted on the TV at the time. Mr. Robinson had not been a UFO believer until this experience.

Reports of mini-UFOs are rare in comparison to the number of larger unidentified aerial objects we hear about. Here in Pennsylvania, we have investigated several such incidents in the last 20 years. We have cases on file where very small objects ranging in size from several inches to a few feet in diameter, were observed entering a car where the window was left down, hovering around the heads of people on a golf course in Pittsburgh and flying around the interior of a home.

Even though the two observers of this mini-UFO didn't know it, our PASU unit has been receiving almost yearly reports of low level UFO activity, from several areas close to the Level Green area.

For further information please contact (PASU) the Pennsylvania Association For the Study of the Unexplained, 6 Oakhill Avenue, Greensburg, Pa. 15601 or call the Pa. UFO Hotline at 412-838-7768.

\*The actual names and addresses of the real observers are on file with MUFON.

## IN OTHERS' WORDS

By Lucius Farish

UFO reports over the Pyrenees mountains of France are detailed in an article in the April 9 issue of **NATIONAL ENQUIRER**. A photograph of one object was obtained by a ski instructor and police officers sighted yet another UFO in the same area. Soviet UFO reports and a mysterious "cold fire" are featured in the **ENQUIRER's** April 23 issue. The May 14 issue contains the testimony of Danish Air Force Major Hans Petersen concerning hostile UFO incidents. However, at least one of the cases cited originated with highly questionable sources and is probably fictional.

The **NATIONAL ENQUIRER UFO REPORT** is a new paperback from Pocketbooks, containing rewritten material taken from **ENQUIRER** issues of the past several years. The book covers numerous aspects of the UFO subject and, while it might be wise to keep your salt shaker handy while reading it, it does make it handy to have the "highlights" of such reports between two covers. It is now available at newsstands or may be ordered from Pocket Books - Dept. NAT - 1230 Avenue of the Americas - New York, NY 10020. Add 75¢ for postage and handling on mail orders; the book is priced at \$2.95.

Dr. Brue Maccabee's series of UFO articles continues in **FATE**. The May issue contains two "classic" cases of daylight discs, while the article in the June issue deals with UFO landings in the Southwest (the Levelland, Texas, cases from 1957 and the Socorro, N.M., case of 1964).

The "Anti-Matter/UFO Update" column in April **OMNI** is devoted to the research conducted by Ellen Crystall near Pine Bush, New York. A great deal of UFO activity was reported in the area and Crystall comments on the investigations which she and Harry Lebelson conducted.

Readers who have obtained Dr. Jan Pajak's **THEORY OF THE**

**MAGNOCRAFT** (mentioned in a previous column) may like to know that he has another paper available, **THE OSCILLATORY CHAMBER**. As with his previous writings, this is a technical dissertation on possible UFO propulsion methods and related phenomena. Pajak's material is extremely interesting, even for anyone (such as myself) who doesn't fully appreciate the technical aspects. More information on Pajak's research and publications can be obtained from him at: P.O. Box 1705 - Invercargill, New Zealand.

A word of warning to videophiles in the reading audience. United Entertainment, Inc. of Tulsa, Oklahoma, is currently offering videotapes of two "documentaries," **UFO—TOP SECRET** and **ATTACK FROM OUTER SPACE**, at \$13.95 each. If that seems like a bargain, be assured that it isn't. These two films have to be the worst attempts at documentaries (on any subject) that it has ever been my misfortune to watch. You will be well advised to save your money.

— **MUFON** —

**AMATEUR  
RADIO  
NET**

---

**EVERY SATURDAY  
MORNING  
AT 0800 EST (OR DST)  
ON 7237 KHz S.S.B.**

# THE CASE FOR E-T CONTACT

By Philip Mantle

By the end of this century, we should know if we are alone in the cosmos. Scientific evidence indicates superior beings from other worlds are apt to find us.

Can you imagine a form of life as far beyond man as man is beyond the worm? Science assures us that such highly evolved beings must exist on the stars and planets around us, if life is common in the Universe.

These Extraterrestrials are not like the flower children in CLOSE ENCOUNTERS OF THE THIRD KIND or the space cowboys of STAR WARS. They are creatures whom we will judge to be possessed of magical powers when we see them. By our standards they will be immortal and omnipotent. They are the kind of creatures who would be capable of a trip to the Earth from another star.

## OTHER SUNS

How can these bizarre notions be supported by science? Here is the evidence. One hundred billion stars like the sun surround us in our galaxy alone, according to indirect but solid astronomical evidence; many have planets made up of the same ingredients as the Earth. These planets have water and air and the same structure for climate as that of the Earth. The molecules on their surfaces enter into the same chemical combinations, subject to the same laws of chemistry and physics, as molecules on our planet. All the necessary elements for the evolution of life are present, simple unthinking life at first, and complex intelligent life later on.

On the basis of these considerations, I believe that life is common on the many planetary systems in the Universe. Recent discoveries in astronomy prove that if life exists on other planets in the Universe, most of this life is far older than life on Earth. The discoveries relate to the so-called Big Bang theory, which holds that the Universe started

with a huge explosion. The Big Bang theory has now been proved to be a fact by the Nobel Prize-winning work of ARNO PENZIAS and ROBERT WILSON, who discovered the remnant of the primordial flash of light and heat that filled the Universe at the time of the great explosion. In other words, they discovered a relic of events that actually took place shortly after the beginning of the world. Although many astronomers had resisted the Big Bang theory, the PENZIAS-WILSON discovery has convinced most of them.

## BIG BANG

The importance of the Big Bang in a discussion of UFOs and life on other worlds is that it tells us when the world began, it tells us the age of the Universe. An astronomer can calculate on the back of an envelope how long ago the Big Bang occurred. That moment marked the birth of the Universe. The result of the calculation is that the Universe came into being 20 billion years ago.

The Earth, on the other hand, was born only 4.6 billion years ago. That result comes from measurements of the ages of meteorites and from the ages of the rocks brought back by Apollo astronauts. Since meteorites and the moon are relatively unchanged samples of solar-system material, dating back to the birth of the planets, their age is thought to give a good estimate of the age of the Earth.

Thus many planets circling distant stars are 5, 10 and even 15 billion years older than the Earth. It follows that the Earth is a very recent arrival in the cosmic family of planets, and man is among the youngest citizens of the Universe.

Of course, the fact that life elsewhere is older than man does not necessarily mean that this life is more intelligent. However, the scientific evidence suggests that this is likely to be the case. Throughout the last 300 million years of life on Earth, only one

seemingly universal trend can be discerned in evolution, and this is the trend towards greater intelligence. Since before the fishes left the water, the most intelligent form of life present on Earth in each era has been the rootstock out of which new and still more intelligent forms have evolved. The line of increasing intelligence stretches unbroken from the fishes to the reptiles to the mammals, the primates and man. Apparently, intelligence which permits a flexible response to changing conditions, has a greater survival value than any other single trait.

Now we come to a critical point. Why would a line of evolution that has proceeded unchecked for hundreds of millions of years stop at the particular level of intelligence that we call "human"? Homo Erectus had less brain power than Homosapiens has, the successors to Homosapiens should have more. If the past is any guide to the future, our descendants a billion years from now will surpass us in intelligence. And if the Earth is typical of planets in the universe (and everything we know in astronomy and geology tells us that it is), intelligent beings who live on planets billions of years older than the Earth have already reached that advanced level of intelligence that our successors will only achieve in the distant future.

This argument, proceeding step by step on the basis of evidence acquired in the basic scientific disciplines, leads to the conclusion that life on other worlds is not only billions of years older than man, but also billions of years beyond him in intelligence.

## HEADSTART

What does a billion years mean in the evolution of intelligence? For an answer, look again at the fossil record. One billion years ago, the highest form of life on Earth was a simple wormlike animal. The creatures that dwell on

*(continued next page)*

# The 12 nearest stars outside our solar system

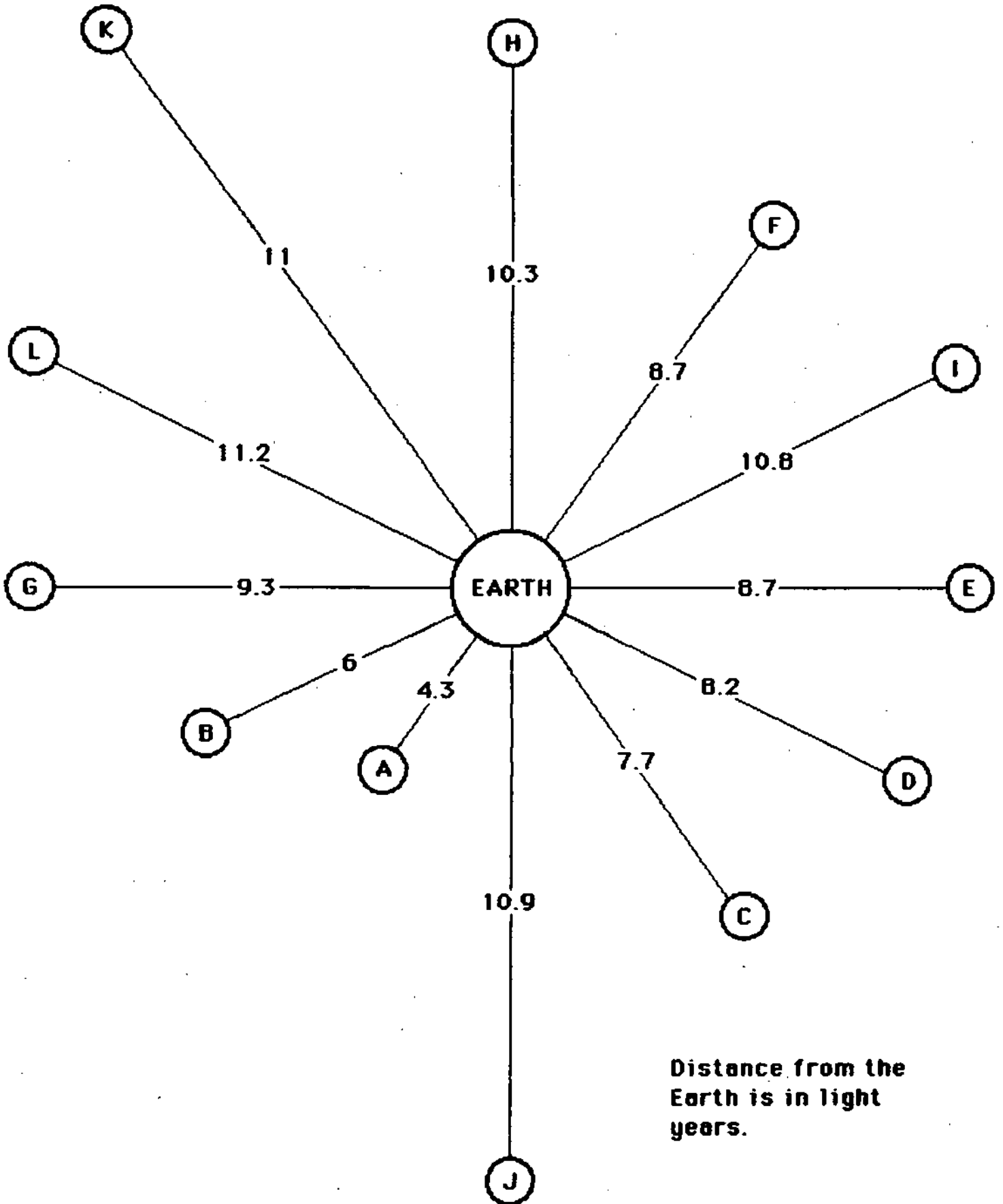

Distance from the Earth is in light years.

Diagram by Philip Mantle/Tom Deuley

Name of Star	Age of Star	Distance from Earth in light years.	Chance of Life
A ALPHA CENTAURI	4.6 Billion years. (approx. same as the sun)	4.3	Good, this triple star is about as old as the sun, Thus was formed when the Universe had large amounts of carbon, oxygen and other elements essential for life.
B BARNARDS STAR	20 Billion years (as old as the Universe)	6	Poor, too old, no carbon etc. available when this star was formed.
C WOLF 359	20 Billion years	7.7	Same as above.
D LAL 21185	20 Billion years	8.2	Same as above.
E SIRIUS	300 Million years	8.7	Poor, it is a young star, any life would be primitive.
F UV CETI	UNCERTAIN	8.7	Poor, it is a flare star, emitting bursts of lethal, ionizing radiation.
G ROSS 154	Younger than the sun. Exact age uncertain.	9.3	Fair if the star is not too young.
H ROSS 248	20 Billion years	10.3	Poor, too old, no carbon etc. available when this star was formed.
I EPSILON ERIDANI	4.6 Billion years (approx. same as sun)	10.8	Good, chance for planets and good chance for life. BEST BET.
J ROSS 128	4.6 Billion years	10.9	Good, chance for planets and fair chance for life.
K L 789-6	20 Billion years	11	Poor, too old.
L 61 CYGNI	20 Billion years	11.2	Same as above.

#### KEY TO DIAGRAM

#### E-T CONTACT, Continued

planets a billion years older than the Earth must possess an intelligence that surpasses us by as much as we surpass the worm.

These considerations bring me full circle to my opening statement. According to the best scientific evidence, intelligent life on other worlds

is likely to be as far beyond man as man is beyond the worm.

Why is it so important, in a discussion of UFOs, to establish a scientific foundation for the existence of races more intelligent than man? The answer is related to the fact that the distances between the stars are so enormously great. If a UFO reaches Earth, its crew must have covered

those enormous distances somehow. They must have started out from someplace beyond the edge of our solar system. They cannot come from the Earth's sister planets, because no intelligent life exists in this solar system except on our own planet. All the evidence acquired by NASA spacecraft in the past few years regarding Venus, Mars and Jupiter points to that conclusion. It follows that UFOs, if they arrive here, have come from another star.

The closest star to the sun is 25 trillion miles away, and it would take one million years to cover that enormous distance with the fastest rockets known to man. Our science and engineering are not adequate to meet that challenge: a trip to the stars is beyond our reach at the present time. But in another billion years, our descendants, possessed of highly evolved minds and with science and engineering far beyond ours, should be able to undertake an interstellar voyage. And what our descendants can do a billion years in the future, other races, a billion years older and more evolved than man, should be able to do today.

My conclusion is that UFOs, visitors from another star, is a scientifically sound concept because science tells us that it is reasonable to believe in the existence of forms of life older and far more intelligent than man.

#### PREVIOUS VISITS?

Has the Earth already been visited by these older more advanced beings? According to some scientists the Bible tells of these visits. Numerous books have appeared telling of visits from these beings throughout the history of mankind.

Are such visits occurring at the moment? Dr. J. Allen Hynek is one of many eminent scientists who have made a study of reported UFO sightings and concludes that several are unmistakably UFOs (Unidentified Flying Objects). He cannot say whether these unidentified objects have come from another star, but there are good reasons for believing that such extraterrestrial contacts, either visitors or messengers, are more probable

(continued on page 17)

# BLUEPRINT FOR PROGRESS

By Richard Hall

In the spirit of other recent analyses of the State-of-the-Art, I offer the following remarks about the status, goals, and future outlook for "UFOlogy". They may seem radical, and surely will offend some people, but we must face up to reality if we ever hope to get anywhere. First of all, we must recognize that "UFOlogy" is a contradiction in terms — there is no "science" of UFO investigation and research. There are many small and a few large UFO groups, some of which have a smattering of scientists as members, and whatever "science" they apply is at best — spare time, sporadic, and unsystematic. Instead of talking about improving or expanding "UFOlogy" we should talk about establishing it in the first place! As it stands, UFOlogy is a pretense — a fiction. Only when qualified scientists are funded to do systematic research will there be a UFOlogy.

On the other hand, a few UFO groups (notably MUFON and CUFOS) do operate in a scientific spirit and attempt to bring scientific resources to bear on the UFO problem, but with the limitations cited above. Basically, that means applying thorough investigative procedures, carefully sifting evidence and weeding out IFOs and hoaxes, and using logic and reason to try to make sense of what is going on. However, resources are woefully lacking and no matter how well-intentioned such efforts are they amount only to stop-gap actions pending real, large-scale scientific investigation. Some very good work is being accomplished, but then the results typically never are read by anyone other than members of the in-group.

## UFO ZOO

We also must learn to see ourselves as others see us — especially *significant others*. Frankly, it is extremely doubtful that important people and opinion-makers in society (more on them later) see us at all, and if

so they are not likely to be able to differentiate us from crackpots and mystics. All of this underlines the importance of the outreach effort being undertaken by Marge Christensen and her colleagues.

By now it should be obvious that the UFO movement speaks with a cacaphony of voices to the public at large, and we end up sounding pretty silly. Just scan through a sample of UFO publications and you will find fundamentalist religious views, mystical and occult themes, automatic assumptions that UFOs are related to every other mystery under the sun, and all sorts of ranting and raving, sometimes including deliberate, conscious efforts to muddle things up worse than they already are by certain people who function effectively as disinformation specialists. Then there are the egomaniacs who must be big wheels, have titles, and run their own splinter groups; they typically find it necessary to take potshots at the larger, better established groups in order to carve out a niche for themselves.

When some potentially important UFO news breaks, none of this is lost on the news media or other significant segments of society because the cranks, mystics, and axe-grinders swarm out of the woodwork and talk loudest of all. Since some of them are "colorful," they are also "newsworthy" to a certain breed of alleged journalists who seek only color and controversy. The general perception on the UFO subject (the existing bias) is that it is much ado about nothing; only fantasy spread by "believers" and wishful thinkers. Thus, many journalists probably feel that they are only reporting things as they really are when they seize on non-sensical aspects of the subject.

## THE ENEMY

On the whole, would-be UFOlogists do a very poor job of public

relations and end up talking only to themselves, aiding and abetting the biases against the subject, and engaging in a lot of pretense. In the famous words of Pogo, "We have met the enemy and he is us!" Skeptics are not our real enemies; they can perform an important function, and in any event we have ample information to deal with them if we use it effectively. News media are not our enemies; they should be our natural allies, and we have failed to understand the needs of the press and how to work with them. Nor is the Government our enemy; though some policy-makers (in our view) have erred on the side of secrecy, many people in Government take UFOs seriously and would like to see an open, scientific study.

No, Pogo was right. We (collectively) are the enemy, and we must police our own ranks.

To get a handle on the problem, we must ask ourselves, "Who are we trying to convince? Who should be reading our information that isn't doing so now?" Unless we are naive enough to believe that the existing rag-tag army of UFOlogists can go it alone and don't need any help, we must have someone — some groups — in mind that we would like to have on our side. I suggest that the prime movers and shakers, the major opinion-makers in our society, are:

- Members of Congress
- Other Government officials
- News media
- Scientists/scientific organizations
- Universities/research centers

These should be the targets of our efforts, *but* — the manner of approach is vital to success, and it cannot be chaotic and disorganized. As a first order of business, these target groups must be made aware that the crackpots, mystics, and opportunists

(continued next page)

## BLUEPRINT, Continued

are not representative of the core UFO problem, and furthermore that we totally disown them and find their actions and ideas reprehensible. *Positive Differentiation* from the cacaphony of voices is essential.

### CONGRESS

For the past five years in my professional work, I have read and abstracted Congressional hearing testimony on a daily basis. The testimony covers issues large and small, some life or death matters and many affecting citizens everywhere (e.g., "Star Wars," Defense Department budgets, social security, aviation safety).

Witnesses appear and testify on every conceivable facet of each issue, pro and con. The arguments are complex and intricate. The busy Members of Congress must listen to warring voices of all kinds and every shade of opinion, and digest what they hear in order to construct legislation or cast a vote.

How do they manage to do this with long lines of interested or affected parties lined up to testify? Three of their basic techniques are relevant here: 1) they confine oral testimony to a brief summary statement and question-and-answer period while placing the longer written testimony in the hearing record for reference; 2) they encourage associations and organizations to pool resources and have one spokesperson; and 3) they commonly require witnesses to appear together as a panel rather than one by one, to speed things along and get to the core of the issue as efficiently as possible.

### LESSONS

There are several lessons in this, the following chief among them: If you want to get the attention of important and busy people, be organized, concise, to the point, and document your statements. Congressional hearing records nearly always include many pages of documents. If your argument or statement is unfocused or rambling, the Congressman's eyes will quickly glaze over.

Where you have common ground with other individuals and/or groups,

work together with them and make one unified approach to the person you are seeking to persuade. Make a clear, logical, coherent case and demonstrate that the views you are presenting represent those of the many people in the common group. Larger numbers of people agreeing on issues and speaking with one voice can be much more persuasive than separate communications from each of the individuals, which are likely to be idiosyncratic and to blur the focus. By the same token, it also makes sense to select as a spokesperson someone who is literate and articulate.

### TOO MANY VOICES

Considering every youngster from each new generation who jumps into the fray, all the egomaniacs, the mystics, the opportunists, and the crackpots, there are far too many voices in UFOlogy, and all too many of them uninformed or discordant. Not much can be done about that, *except* to make it absolutely clear that they do not represent UFOlogy, and to work toward an organized voice for UFOlogy that can be recognized as such and will be respected and heeded. That requires strong scientific and ethical standards, among other things. It does not require a Supergroup; only cooperation among all who hold to the principles and spirit of science.

A blueprint for progress in UFOlogy, then, as a minimum involves the following elements:

- Self-realization, that UFOlogy as presently constructed is not a science, but a stop-gap effort by intelligent and well-meaning citizens to bring the UFO problem to the attention of people with the ability and resources to do something about it.

- Positive differentiation, to articulate clearly that the loudest and most commonly heard voices are not necessarily representative of the real problem and that (in specified instances) we don't agree with them and reject their views.

- Sophistication, including recognition of who our real "enemies" and (potential) "allies" are and how to deal with them.

- Scientific spirit, particularly focusing on truly objective and thorough investigation, documenta-

tion, and scholarship, and the careful use of logic and reason to support our arguments.

- Self-policing, including public rebuke of alleged "UFOlogists" who engage in ego-building self promotion, specious logic, unscientific claims, loose thinking, and the many other destructive behaviors evident in the UFO literature which tend to demean UFO research.

"UFOlogy" really is a very mixed bag of people who, for good and bad reasons, would like to convince the world that UFOs are something important and deserving of serious attention. Some have ulterior motives and wish to see their ideas prevail; others are convinced that science ought to look into the problem far more thoroughly than they have to date. This, in fact, is the dichotomy that needs to be made: between those who think they already have the answer and those who perceive UFOs as a scientific problem badly in need of systematic, thorough, and well-funded investigation. I *think* I already know the answer, but I identify myself with the latter group. What you think you know is a hypothesis; then you need to test that hypothesis — and others — in order to determine the truth.

## SUPPORT NATIONAL UFO INFORMATION WEEK

\*\*\*\*\*

**18-25 AUGUST  
1985**

\*\*\*\*\*

**INFORM YOURSELF  
INFORM OTHERS!**

# THE UFO EVIDENCE: 20 Years After

By Francis Ridge

As a previous Subcommittee Chairman for NICAP I have been comparing MUFON's efforts and the work of other ufologists with the efforts of NICAP since their publication of THE UFO EVIDENCE in 1964. We have, surprisingly, added a lot of interesting data to the statistics of twenty years ago. I am still very impressed with THE UFO EVIDENCE as a basic research tool and feel it is a must for all ufologists. For those who might think that not too much has been accomplished in the last two decades in the subject of UFOs, I have done a little research of my own. I think you will find this useful if you are doing any PR work.

Most people are now more conditioned to be receptive to special evidence cases and cases of high-strangeness (provided there is some believability), rather than just lights in the sky reports. In this area we have come a long way. In 1964, UFO EVIDENCE cited 35 cases of physical evidence. This was covering the entire spectrum of physical & physiological evidence and not what we term "trace cases". The 1981 MUFON Symposium presented Ted Phillip's trace case study which was classified as close encounters of the 2nd kind and represented a catalog of 2,108 events under that heading. Quite an advancement. Regardless of all the inherent technical data & conclusions, the collection alone was a hell of an achievement. In 1980, the Center for UFO Studies put out a computer printout of 5,633 entries.

## RADAR

In the area of radar cases, UFO EVIDENCE listed 81 cases. This was very impressive. I personally xeroxed copies of the reports themselves, found in the open literature and found another 18 cases. I'm sure there are many more since then. I believe and hope someone undertakes the project of radar case studies and think these cases are very significant and

neglected. I found some interesting data in the old Air Force statistics of 1953 in regard to radar reports. Captain Ruppelt stated that there were 429 Unknowns and that 10% were radar cases. That's 42 cases! In the 701 'unknowns' that the Air Force ended up with in 1969, there were less than 20 reports of radar cases.

In my MADAR research (Multiple Anomaly Detection & Automated Recording) I am very especially interested in E-M cases. NICAP listed 106 cases in 1964. Rodeghier published his report through the Center for UFO Studies, entitled "UFO Reports Involving Vehicle Interference" in 1981. There were now 441 documented cases on record.

## PHOTOGRAPHS

In the area of photography and pictures of alleged UFOs NICAP listed 64 cases of either still photos or motion picture filmstrips. Since then Ground Saucer Watch has studied over 600 such items and found about 30 to be authentic as analyzed by their computer. I do not understand the technical aspects or form an opinion as to the remaining 30 to say whether there are more authentic cases or not, but I am impressed that someone is studying 600 photos.

An area of high significance exists in the abduction reports or close encounters of the 4th kind. A project to catalog these cases has been funded by the Fund for UFO Research. Without the aid of a computer and someone to keep it updated, the report will not reflect the total cases on record, but illustrates the high number of CE4's in the open literature. Dr. Leo Sprinkle believes that one out of four people have been abducted! Budd Hopkins has found a considerable number of abduction cases.

According to David Webb in his report, "1973-YEAR OF THE HUMANOID", there were 70 documented cases of humanoid

reports during the fall of that year alone. Six of these were CE4's or missing time/abduction cases.

Some reports that always impressed me were the reports by pilots and aviation experts. NICAP's UFO EVIDENCE listed 118 cases. Dr. Richard Haines has over 3,000 cases on computer. Ninety percent were observed by more than one witness; 85% for more than 1-minute. The data base covers 40 countries. In his "Review of Selected Sightings From Aircraft", Dr. Haines studies 72 cases covering the period 1973-1978. Seventy-two point two percent were from commercial a/c, 19.5% private, and 8.3% military. In the study for the period 1942-1952, 283 cases were selected and 68% were military a/c, 20% commercial, 11% private. (1% unspecified). Twenty-nine cases involved E-M effects.

For those skeptics that think the lights in the sky are simply all conventional objects viewed under unusual conditions by untrained observers, the old UFO EVIDENCE cites just a fraction (17 years of data compared to 38 years) of the now overwhelming evidence for intelligent control of these objects. In 47 cases there was inquisitiveness & reaction to observers, 59 cases of UFOs in geometrical formation with 26 listed as satellite object cases (mothership-types). Intelligent maneuvers themselves were represented in 100 cases with the oft-reported oscillation (wobble on axis) cited in 35 reports. Violent or erratic maneuvers were reported in 40 cases. Ballester's "Close Encounter Cases, Catalog of 200 Type-1 Events in Spain & Portugal" (1976 report through the CUFOS) illustrates that objects within 200 feet of the ground are not rare at all and give the observer an excellent chance to observe a UFO at close range.

(continued on page 17)

**The MUFON 1985 UFO  
Symposium Proceedings  
are respectfully dedicated to  
Norma E. Short**

Public recognition is hereby bestowed upon Norma E. Short for her conscientious editing and publishing of the monthly UFO magazine *SKYLOOK* for over six years. Norma is credited for providing the publishing link for the fledgling Midwest UFO Network that ultimately became the world's largest UFO membership organization — the Mutual UFO Network. She will be remembered for her editorial policy "We Tell It Like It Is." It is with profound gratitude that voluntary dedicated service may be honored in this manner to such a gracious lady.

In 1967, Mrs. Norma E. Short was invited to become the editor of a new UFO newsletter that was to be named *SKYLOOK*. Being a former reporter for the *Salem Post* (Missouri) and a "UFO buff," she enthusiastically accepted the challenge. The inaugural edition on September 1967 carried the motto: "Let's Separate Fact from Fantasy." The founding staff consisted of John F. Kuhn, publisher; Mrs. Short, editor and Ted Phillips, Jr., assistant editor. The nucleus of subscribers came from members of the UFO Study Group of Greater St. Louis and the Tri-State UFO Study Group (Quincy, Illinois).

Norma became both publisher and editor in January 1969, necessitating the purchase of a mimeograph machine that she lovingly dubbed "the monster." The staff in the February 1968 masthead listed Ted Phillips, John Schuessler, Walter Andrus, Lucius Farish and Mrs. R.E. Holmes. The column "In Others' Words" by Lucius Farish was introduced in June 1969. The 24-page July 1969 edition announced that *SKYLOOK* had been named the official publication of the Midwest UFO Network (MUFON) with Allen R. Utke, Ph.D. as Director. "A Message From Your Director" column started in October 1970 when Walt Andrus was elected Director of MUFON.

By the fall of 1973, the circulation of *SKYLOOK* had reached 700,



reflecting the fantastic work of Mrs. Donald H. Short and her dedicated staff. Toward the end of 1973, Norma sadly realized that even with the aid of an electric typewriter, the arthritis in her fingers would prevent her from typing camera-ready copy for the printer and maintaining her extensive correspondence. In her final edition in January 1974, Mrs. Short had these words for her readers; "Parting is such sweet sorrow according to Mr. Shakespeare's Juliet — but I don't agree, as I come to the point where I have to announce this is Ye Ed's last issue of *SKYLOOK*. Parting is

just...sorrow."

Under Norma's six-year editorship, *SKYLOOK* earned the respect and reputation as one of the leading monthly UFO publications in the world. Norma had nurtured her "child" from a 5-page newsletter to an "adult," full-fledged UFO magazine. In June 1976, the name was changed from *SKYLOOK* to the *MUFON UFO JOURNAL* to more adequately identify its contents, goals and purposes. *SKYLOOK* was published in Stover, Missouri; however, since retiring, Mrs. Short now resides at 723 McGrath Lane, Salem, MO 65560.

---

### **RENDLESHAM, Continued**

Sgt. Yarborough is straight-as-an-arrow; a humorless career man who goes strictly by the rules. Doesn't look to the right or left. It was prudent to drop the subject there and then. Jenny makes quite a point that when the book was written (1983) no one remained on base who had been stationed there during the UFO events. A flow-chart analysis would automatically weed out this type of extraneous material.

Dot named an American ufologist whom she understood is under contract—not only for a book on the Rendlesham Forest Affair, but also a dramatic film script. And Dot said that she and Jenny are seriously underway

with a follow-up book of their own on the case (Brenda has pretty much dropped out of things).

It remains to be seen whether any of these endeavors clarify the Rendlesham Forest Affair. Meanwhile, without the cooperation of eyewitnesses, we are left with a jigsaw puzzle of unknown dimensions, no box-top picture, and a dreadful surmise that—while some pieces are missing, others, entirely irrelevant, have been scattered at our feet.

### **NOTES**

1. Neville Spearman Co., Suffolk, 1984.
2. The entire trip was a fluke. My husband had engineering consulting work at RAF Bentwaters (sister base to Woodbridge), and aware of the case, and my interest in it, he invited me along.

## LETTERS

-By the Readers

**Dear Editor,**

The MUFON Monthly Journal has my vote for excellence in reporting the current scene. However, I find your publications even more informative when incorporated with other related newsletters; especially the Lucius Farish UFO Newsclipping Service in Arkansas.

For instance: You published a report by Larry W. Bryant regarding the August 25, 1984 UFO Town-Hall Meeting in Brewster, New York (see Oct. 1984 Journal No. 198). A grand event, indeed. But several articles included in the "Newsclipping Service" enhanced it all. You became aware that the forum had captured wide media coverage in newspapers throughout the Northern East Coast.

Reports showcased a historical perspective of the day's events, the speakers, their viewpoints and occupations and the vast amount of aerial sightings.

It seemed as if I had actually attended the forum, met all the participants and experienced the vibrant atmosphere inside and out of the Henry Well's Middle School on that sunny August day.

It should be imperative for any MUFON reader who hasn't yet subscribed to the UFO Newsclipping Service, to do so immediately; or else they will be missing out on a significant amount of up-to-the-minute information.

Sincerely,  
**Joan H. Laurino**  
San Francisco, CA

**Dear Editor,**

May a mere subscriber take exception to the surfacing of James Oberg in your April issue?

Not for a moment can we deny that rocket launchings have spurred various UFO reports, but neither can we deny that Mr. Oberg's commitment to the

anti-UFO position is total; that his NASA connection and general stature allow him almost instant national media access at the literal snap of a finger—a factor now denied those on the "pro" side.

If you were going to be shot at sunrise would you help the firing squad load the rifles? Well, that's what you're doing by handing out a free platform to the all commanding professional debunkers.

In a state of disbelief, I remain,  
**Jack P. Swaney**  
Las Vegas

*Of course a "mere" subscriber to the Journal can take exception to the appearance of James Oberg in its pages. Without such subscribers, mere or otherwise, obviously there would be no Journal in the first place!*

*On the other hand, Oberg may take exception to your appearance, and then what's an editor to do? He or she hopefully does what this one does, and that is to present both sides of the argument. Like Oberg personally or not, agree with his thought or not, it cannot be denied that his article, "South American Uforia," contained valuable data, particularly the table of Soviet satellite launches, that helps us all separate the chaff from the wheat of ufology. And it was for that reason alone it was published.*

*As editor, I don't particularly feel it's my duty to censor someone or some viewpoint before you, the reader, have the opportunity to weigh and respond yourself. In this particular instance, I think we've both done our job, and I appreciate your comments.*

**-Editor**

**Dear Editor,**

It is little wonder the general public, the news media and the scientific community give small credence to the numerous UFO

sightings reported. In excess of half the verbiage published describing these events is devoted to provocative theories of extra-terrestrial, hollow earth dwellers or other esoteric origins of the phenomena, thus detracting from the prime motive of determining the individual parameters and characteristics of the objects involved.

This approach to analysis provides a fertile field for the debunkers, who delight in attacking a theory which is obviously indefensible, particularly when the described event borders on the para-normal. Opposition to those who dissect some of these stories becomes difficult when the content sometimes approaches what you would expect to find in publications on the order of Fate Magazine.

The logic demonstrated in James McCampbell's article (No. 189, November 1983) titled "UFOs AND HOT RINGS" is exemplary as the text adheres to known and accepted physical laws and illustrates a keen insight into the properties of UFOs. Particularly interesting are his references to the orientation of the rings relative to the field of radiation and the fact the skin was only burned under the rings.

The article by Michael D. Swords, Ph.D. in the same issue titled "COULD LOOKALIKE ASTRONAUTS BE CLONES", although debunking in nature it should be read and heeded by most writers as it points up the fallacy of expounding a theory which is not based on factual evidence. His caution to "do your homework" is well taken.

With the advent of computers and available and economical computer leasing time, all of the recorded UFO sightings and verification methods, placed in the appropriate time frames, could be categorized and published (see accompanying chart). A document of this stature would establish a solid

(continued next page)

## UFO EVIDENCE, Continued

Comparing our efforts with those of the Air Force, you can see who's working on the problem. It's very much like the oil business; 90% of the oil in this country is produced by the little independents. As far as we are concerned, their best effort was in the early 50's and the statistics then were not only more accurate, but revealing. Out of 1,593 cases, 429 were listed as "unknown", 26.94%. Insufficient Data reports totaled a whopping 22.72%. More information here could have meant more "unknowns". The Air Force always said that if they would have had more information, even the 26.94% would have been reduced! In actuality, Balloons listed as 18.51% were actually known as balloons in only 1.57% of the cases. Possible balloons 4.99 & probable 11.95%, and so on with Aircraft, Astronomical cases, etc. The real hard truth and the bottom line is this:

Known Balloons, Aircraft, Astronomical cases	11.21%
Possible	16.74
Probable	22.39
Insufficient Data? (Come now!)	22.72
UNKNOWN	26.94
Hoaxes	

Hoaxes (A surprising admission)	1.66
Other	4.21

(Insufficient data was actually 61.85%)

Amazing as the above figures are, there is more. The Air Force had 429 Unknowns in 6 years and during the next 17 years only 272 more Unknowns were added and most of the database in the early years were military cases. When Blue Book closed in 1969 they had 701 Unknowns on the books. The 1953 figures, more accurate when the Air Force took a serious role, showed that pilot reports constituted 17.1%. Scientists & engineers reported 5.7%, followed by Air Route Traffic Controllers at 1.0%. Radar cases represented 12.5%. Military & civilian cases, other than those just mentioned totaled the remaining 63.7%. Ruppelt stated that the Air Force assumed 1 out of 10 sightings was reported. This

meant that from 1947 to 1953, 44,000 sightings were made in the US alone.

Before you wonder where the 44,000 came from, Ruppelt stated that the Air Force had actually received 4,400 reports, but all except 1593 cases had been immediately rejected for the special analysis! He therefore extrapolated that there were over 39,000 not reported!

One thing we can all agree on, where there is smoke there is usually fire. Where there is a lot of smoke, you had better dial 911!

## E-T CONTACT, Continued

today than ever before in the history of our planet. Since about 1960, television stations across the Earth have been spraying their signals into space at a million-watt level. In the course of the last 20 years, that exploding shell of television signals, moving away from Earth at the speed of light, has travelled 240 trillion miles. It has now swept past 40 stars in the neighborhood of the sun.

Early TV programs, moving away from the Earth at the speed of light, have carried the message to these stars that intelligent life exists on this planet. These television signals make the Earth the brightest radio star in our neighborhood of the galaxy of TV frequencies. For the first time in 4.6 million years, our planet is a notable object in the heavens. If any of these 40 nearby stars harbour intelligent beings, our presence is now known to them. As it took 20 years for our signals to reach these stars, it must take 20 years for their reply travelling at the same speed, to get back. Unless man is alone in the universe, we can expect to receive a message, or a visit by the end of this century (unless they have already arrived).

And would these superior beings bother to talk to us? In their eyes Einstein would qualify as a waiter and Thomas Jefferson as a busybody.

I think they would. They are jaded, they have lived a billion years, they have done nearly everything, they are eager for fresh experiences. After all, where else in the universe have they seen a creature like man before?

## LETTERS, Continued

factual data base helping to persuade the skeptics that we are not "just whistling Dixie."

Additional factual evidence compiled in a like manner could then indicate the areas of the sightings in geographical locations vs, the time frame, illustrating the tracking of UFO movements on a global scale.

A hard nosed "nuts and bolts approach" to the phenomena would go a long way toward gaining acceptance and the use of graphics could be extended to the analysis of landing site data, electromagnetic effects and observations of various propulsion variations recorded. Charts and graphs are a most effective way of presenting evidence and are more easily assimilated by the reader, especially those in the field of science.

I am personally convinced UFOs are E.T. in origin, but equally sure we should attack the problems of what they are, where they appear, when and in what quantity, etc., before we attempt to theorize on their base of operations. Let us organize a truly investigative force and track down the facts, organizing and displaying them in a logical manner as a law enforcement agency would operate.

After all, if you were being observed at various times and locations by a variety of unknown observers, your priorities would be to obtain the physical characteristics of your observers, the frequency of observation and the locales involved before becoming concerned with their place of residence.

The credibility of UFOs is in our hands. Let us maximize the opportunity by presenting factual evidence in an orderly and easily assimilated manner. Such an effort could substantially reduce the existing credibility gap now facing us.

**Cliff Henderson, M.E.E.**  
MUFON Research Specialist,  
Propulsion Systems  
Sunnyvale, Calif.



## MESSAGE, Continued

Director of Intelligence and Office of Naval Intelligence. Originally classified TOP SECRET, it was declassified on March 5, 1985. Some of the UFO sightings reported are part of Edward J. Ruppelt's book *The Report on Unidentified Flying Objects*. In a letter dated 25 Sept 1950, the Dept of the Air Force Headquarters U.S. Air Force, ordered the destruction of Air Intelligence Report Number 100-203-79. In order that the readers of the MUFON UFO JOURNAL may have access to this significant historical study, the majority of the July 1985 issue will be devoted to a reprint of the document. Some of the photographs of UFOs and flying wing aircraft in the report will not be reproduced due to the poor quality of the copying process by the U.S.A.F.

### UFO NEWSCLIPPING SERVICE

The UFO NEWSCLIPPING SERVICE will keep you informed of all the latest United States and World-Wide UFO activity, as it happens! Our service was started in 1969, at which time we contracted with a reputable international newspaper-clipping bureau to obtain for us, those hard to find UFO reports (i.e., little known photographic cases, close encounter and landing reports, occupant cases) and all other UFO reports, many of which are carried only in small town or foreign newspapers.

"Our UFO Newsclipping Service issues are 20-page monthly reports, reproduced by photo-offset, containing the latest United States and Canadian UFO newsclippings, with our foreign section carrying the latest British, Australian, New Zealand and other foreign press reports. Also included is a 3-5 page section of "Fortean" clippings (i.e. Bigfoot and other "monster" reports). Let us keep you informed of the latest happenings in the UFO and Fortean fields."

For subscription information and sample pages from our service, write today to:

UFO NEWSCLIPPING SERVICE  
Route 1 -- Box 220  
Plumerville, Arkansas 72127

## THE NIGHT SKY

By Walter N. Webb  
MUFON Astronomy Consultant

July 1985

### Bright Planets (Evening Sky):

Saturn is low in the southern sky at dusk and sets south of west about 1:30 AM Daylight Time in midmonth. The yellow planet resumes its normal eastward motion in Libra on the 26th.

Jupiter, still brightening in Capricornus, rises in the east-southeast about an hour after sunset in midmonth. The moon lies below the giant planet on the Fourth of July and also on the 31st.

### Bright Planets (Morning Sky):

Venus shines brilliantly low in the east during morning twilight, while Jupiter (3½ times fainter) illuminates the southwestern sky. The former rises about 2:30 AM in midmonth. Venus appears 5° to the right of the crescent moon on the 14th and 3° above the orange star Aldebaran on the 15th.

### Meteor Shower:

The July or Delta Aquarid meteors extend from about mid-July to mid-August. They peak on the morning of July 28 at a rate of about 20 per hour. Wait until the bright gibbous moon sets about 2 AM to begin observing that morning. Although the meteors appear to radiate from a point in Aquarius in the southern sky, the glowing streaks of light do not become visible until some distance away from the spot. Thus, the viewer should scan the whole sky for the relatively slow Aquarids which leave long paths across the heavens.

### Moon Phases:

Full moon--July 2  
Last quarter--July 9  
New moon--July 17  
First quarter--July 24  
Full moon--July 31

Note two full moons in one month. The second full moon is sometimes called a "blue moon," a term derived from another unusual event when forest fire smoke may tinge the moon bluish. Hence, "once in a blue moon." A double full moon occurs again in May 1988.

### The Stars:

The Summer Triangle is now well up in the eastern sky after twilight ends. The star in each corner of the triangle belongs to a separate constellation: Vega lies in Lyra the Harp, Deneb in Cygnus the Swan, and Altair in Aquila the Eagle. Below the triangle appears a heavenly hint of autumn--the Great Square of Pegasus.

The constellations of spring--Leo, Bootes, Virgo, Libra--are slipping toward the western horizon. In the south, Scorpius crawls westward. This pattern is one of the easiest to spot, with head and curved claws to the west and curling tail to the east. The star Antares marks the red heart of the scorpion.

In the north, the Big Dipper stands to the west or left of Polaris the North Star. Use the pointer stars in the dipper's bowl to locate Polaris.

## MESSAGE, Continued

David M. Jacobs will moderate the program, featuring the following speakers: Dr. J. Allen Hynek, John Schuessler, Budd Hopkins, Barry Greenwood, Dan Wright and Marge Christensen. For further information, contact Mass. MUFON, Inc., P.O. Box 176, Stoneham, MA 02180.

The Montana Chapter of S.B.I. is sponsoring a UFO Conference at the Holiday Inn of Great Falls on June 14, 15 and 16, 1985, using the theme — A Piece of the Puzzle: The Public's Role in Research." The scheduled speakers are **Peter Mazzola, James Leming, Major Colman Von Keviczky, Linda Moulton Howe, Dr. Kirk Seekins and Capt. Keith Wolverton.** Lecture package fees are 1 day - \$3.50, 2 days - \$6.00 and 3 days - \$8.50. The Holiday Inn is located at 1411 - 10th Ave. South, Great Falls, MT 59405 and hotel reservations may be made by calling (406) 761-4600.

The Sixth Annual Rocky Mountain Conference on UFO investigations is being held July 11-13, 1985 at the University of Wyoming in Laramie, sponsored by Pro/UFO's and IF UFOCS (**Douglas G. Tipton and R. Leo Sprinkle, Ph.D.**). A registration form and more details may be obtained by writing to Conferences and Institutes, P.O. Box 3972, University Station, Laramie, WY 82071-3972.

\*\*\*

The CUFOS UFO Exhibit was on display at the Future World Exposition at the Mascone Center in San Francisco, Calif. on April 17 through the 21st. John Timmerman contacted Tom Gates and asked if he would handle the exhibit arrangements. It became a cooperative venture for CUFOS and MUFON as members in the San Francisco Bay Area manned the booth, passed out literature and answered questions. An appreciative thank you is extended to the following members for participating in this public education exhibit; Paul Norman (Australia), Jim McCampbell, Ron Lakis, Stan Musselman, Virgil Staff, Paul Cerny, Bill McGuigan, Bruce Shelton, Tom and Della Page, Harry Potter, Dick Henry, Bill Diangson, Cliff Eagleson, Roger Godt, Steve Kiefel and



Tom Gates.

\*\*\*

**The UFO Literature A Comprehensive Annotated Bibliography of Works in English** by Richard M. Rasmussen has been published by McFarland & Company, Inc., Box 611, Jefferson, North Carolina 28640, telephone (919) 246-4460. Published and released May 1985, the price of the hardback (cloth, 263 pages) is \$29.95. Mr. Rasmussen has been collecting UFO information literature for many years and this is the culmination of his detailed and painstaking research. The format is by author and the index by book title and author. (It lists MUFON UFO Symposium Proceedings from 1972 through 1983 by editors, and includes speakers, titles, themes, and locations of each Symposium, as an example.) Richard has included a source of "Where to Find New and Out of Print UFO Titles," although some addresses are already obsolete. In addition to the Introduction, two chapters are devoted to "The Nature of the Literature" and "UFOs in Literature: A Brief History," which sets the stage for the Annotated Bibliography. This book is a good supplement to the computer reference catalog developed by David Christensen for MUFON. The author may be contacted at address: Richard M. Rasmussen, 4589 - 70thSt., LaMesa, California 92041.

\*\*\*

Through the generosity of **Robert Todd and Peter A. Gersten,** MUFON recently received a large number of U.S. Air Force documents declassified on January 29, 1985 under the Freedoms of Information Act (FOIA). Mr. Todd is to be commended for his diligent research on behalf of Citizens Against UFO Secrecy (CAUS) and for sharing his work with MUFON. Most of the documents are from the year of 1952. Also included is the 18 pages of unclassified correspondence prompted by Chuck de Caro's inquiry into the Bentwaters AFB case of December 1980 when he was preparing the Cable News Network (CNN) Special Assignment Documentary. We will publish the series of questions and answers posed by Mr. de Caro and the answers the U.S.A.F. received from USAF Ramstein AB (Germany), RAF Bentwaters (England) and RAF Mildenhall (England) in a future issue of the Journal.

However, a very significant report dated December 10, 1948 was probably the source material for the now famous *Estimate of the Situation*, in which Project Sign personnel at A.T.I.C. declared in 1948 that "UFOs were interplanetary." This 26-page document is Air Intelligence Report No. 100-203-79, titled "Analysis of Flying Objects in the U.S.," Air Intelligence Division Study No. 203, dated 10 December 1948 (by

(continued on page 18)

# DIRECTOR'S MESSAGE

by  
Walt Andrus

The MUFON 1985 UFO Symposium in St. Louis, Missouri on June 28, 29, and 30 will be remembered by the attendees as another successful conference when this issue reaches our readers in the far corners of the Earth. The speakers at the sixteenth annual MUFON symposium were **Marge Christense, George D. Fawcett, Leonard H. Stringfield, Budd Hopkins, John F. Schuessler, Ted Phillips, David F. Webb, William L. Moore, Stanton T. Friedman, and Peter A. Gersten**, addressing the theme — "UFO: The Burden of Proof." The MUFON 1985 UFO Symposium Proceedings are dedicated to Mrs. Norma E. Short, the Editor of **SKYLOOK** from its inception in September 1967 through January 1974.

\*\*\*

The **MUFON 1985 UFO Symposium Proceedings** will be available at the St. Louis symposium for \$10.00 and by mail after July 15, 1985 for \$11.50 which includes postage and handling.

\*\*\*

**Richard D. Seifried**, State Director, has appointed **Fred W. Hays** of Kettering to be the Assistant State Director for Ohio. **James C. DeLotel** has accepted the position of State Section Director for the southeastern counties of Clark, Floyd and Harrison in Indiana. **Thomas P. Deuley**, State Director for Texas, has approved the appointment of **Virgil Gordon Wells** as the new State Section Director for Liberty and San Jacinto Counties. **Donald A. Johnson** has selected **Dale Goudie** to be the State of Washington Public Relations Director.

\*\*\*

The Mutual UFO Network is a founding member of The International Committee for UFO Research (ICUR). The aims of ICUR shall be to promote, undertake and standardize the investigation and research on the UFO phenomenon on a global basis and in a

scientific manner. It shall also be the task of the Committee to disseminate factual information on its workings to all interested parties. Starting in 1979, there has been interim activity taking place under the name of "The Provisional Committee for UFO Research" (PICUR). **Dr. Michael Sinclair**, MUFON International Coordinator, has been the MUFON representative at all of the meetings to date. Officers elected on August 26, 1983 at the annual meeting are **Bertil Kuhlemann**, (Sweden) Chairman; **Bjarne Hakansson**, (Sweden) Secretary; and **Robert Digby** (England) Treasurer. **Peter A. Hill** (Scotland) was the former chairman. The founding member organizations and their representatives at the August 1983 meeting in London, England were CUFOS/USA, **J. Allen Hynek** (President Emeritus of ICUR); SUFOI/Denmark, **Per Anderson**; BUFORA/England, **Robert Digby**; UFOCAN/Canada, **Stanton T. Friedman**; Project URD/Sweden, **Bertil Kuhlemann** VUFORS/Australia (Victoria), **Paul Norman**; and MUFON/USA, **Michael Sinclair**. MUFON annual dues are based upon a member organization of between 1000 and 1999 members. MUFON elected to resign from the very unstable North American UFO Federation in August 1984 and will concentrate its efforts with the prestigious ICUR on an international scope.

\*\*\*

We are extremely proud of **Marge Christensen**, Director of Public Relations and Massachusetts MUFON, Inc. for producing the UFO documentary for the Mutual UFO Network as a public relations function. Designed for a 60-minute time slot on television, the videotaped program is hosted by **Dr. David M. Jacobs** and features segments by **Dr. J. Allen Hynek, Walt Andrus, John Schuessler, Budd Hopkins, Barry**

**Greenwood, Dan Wright and Raymond Fowler**. Videotapes are now available in 1/2 inch VHS or Beta format for \$20.00, as well as in 3/4 inch VHS or Beta format for \$50.00. Checks should be made payable to: Mass. MUFON, inc., and mailed to **Marge Christensen** at 2 Cherry Road, Beverly, MA 01915. This film will be an integral part of the National UFO information Week observance on August 18 to 25, 1985. Please order your copies now so you will be prepared for showing on local cable systems, P.B.S. TV, and public educational exhibits.

\*\*\*

The nationally syndicated ABC-TV program "Eye on Hollywood," featuring UFOs, was viewed on May 9, 1985. Arranged by **Bill Moore**, live interviews were conducted with people directly involved in the Roswell, New Mexico crash in 1947. Motion picture footage from the film "UFOs Are Real" was shown as well as interviews with some of the witnesses who previously participated in the MUFON 1983 UFO Symposium in Pasadena, Calif. The original plan was to show the MUFON UFO Hotline telephone number (512) 379-9216 on the screen when the program host announced "where to report UFO sightings." A last minute change was made in the programing whereby the number was left out and viewers had no idea whatsoever where to report UFOs. While being interviewed, a credit appeared identifying "William L. Moore, Mutual UFO Network."

Everyone is reminded that July 1st is the deadline for submitting early registrations for the UFO Forum sponsored by Mass. MUFON on August 17 & 18 in Beverly, Mass. Anyone planning to attend should make their motel reservations immediately, as motels in the area are already filling up for that weekend. Dr.

(continued inside)

# MUFON UFO JOURNAL

NUMBER 207

JULY 1985

Founded 1967

OFFICIAL PUBLICATION OF



MUTUAL UFO NETWORK, INC.

\$1.50

~~TOP SECRET~~

Air Intelligence Report No. 100-203-79

## ANALYSIS OF FLYING OBJECT INCIDENTS IN THE U. S.

Air Intelligence Division Study No. 203  
10 December 1948

Directorate of Intelligence and Office of Naval Intelligence

DISTRIBUTION "C"

**WARNING:** This document contains information affecting the national defense of the United States within the meaning of the Espionage Act, 50 U.S.C., 31 and 32, as amended. Its transmission or the revelation of its contents in any manner to an unauthorized person is prohibited by law. Reproduction of the intelligence in this publication, under the provisions of Army Regulation 380-5, is authorized for United States military agencies provided the source is indicated.

Directorate of Intelligence  
Headquarters United States Air Force

Office of Naval Intelligence  
Navy Department

Washington, D. C.

DECLASSIFIED

Authority AEINA Memo 5/14/85

By SM ... DATE 3/1/85

~~TOP SECRET~~

**MUFON UFO JOURNAL**  
 (USPS 002-970)  
 (ISSN 0270-6822)  
 103 Oldtowne Rd.  
 Seguin, Texas 78155-4099

**DENNIS W. STACY**  
 Editor

**WALTER H. ANDRUS, JR.**  
 International Director and  
 Associate Editor

**THOMAS P. DEULEY**  
 Art Director

**MILDRED BIESELE**  
 Contributing Editor

**ANN DRUFFEL**  
 Contributing Editor

**TED BLOECHER**  
**DAVE WEBB**

Co-Chairmen,  
 Humanoid Study Group

**PAUL CERNY**  
 Promotion/Publicity

**MARGE CHRISTENSEN**  
 Public Relations

**REV. BARRY DOWNING**  
 Religion and UFOs

**LUCIUS FARISH**  
 Books/Periodicals/History

**ROSETTA HOLMES**  
 Promotion/Publicity

**GREG LONG**  
 Staff Writer

**SIMONE MENDEZ**  
 Staff Artist

**TED PHILLIPS**  
 Landing Trace Cases

**JOHN F. SCHUESSLER**  
 Medical Cases

**LEONARD STRINGFIELD**  
 UFO Crash/Retrieval

**WALTER N. WEBB**  
 Astronomy

**NORMA E. SHORT**  
**DWIGHT CONNELLY**

**DENNIS HAUCK**  
**RICHARD H. HALL**  
**ROBERT V. PRATT**

Editor/Publishers Emeritus

The MUFON UFO JOURNAL is published by the Mutual UFO Network, Inc., Seguin, Texas. Membership/Subscription rates: \$15.00 per year in the U.S.A.; \$16.00 foreign in U.S. funds. Copyright 1985 by the Mutual UFO Network. Second class postage paid at Seguin, Texas. POSTMASTER: Send form 3579 to advise change of address to The MUFON UFO JOURNAL, 103 Oldtowne Rd., Seguin, Texas 78155.

# NOTE

The pagination of the original Air Force document as produced may not necessarily match that of the Journal-Ed.

~~TOP SECRET~~

## ANALYSIS OF FLYING OBJECT INCIDENTS IN THE U. S.

### INDEX

	Page
<u>SUMMARY AND CONCLUSIONS</u> . . . . .	1
<u>APPENDIX "A" - ANALYSIS OF FLYING OBJECT INCIDENTS IN THE U. S. AND HYPOTHETICAL TACTICS EMPLOYED</u> . . . . .	3
Introduction . . . . .	3
Some Aspects Regarding Flying Object Incidents . . . . .	3
Possible Origin of Unusual Flying Objects . . . . .	4
Possible Reasons or Tactics for the Use of Soviet Unconventional Aircraft Over the U. S. . . . .	5
Conclusion . . . . .	6
<u>APPENDIX "B" - REPORTED SIGHTINGS OF FLYING OBJECTS AS OF 1 AUGUST 1948</u> . . . . .	7
<u>APPENDIX "C" - SELECTED REPORTS OF FLYING OBJECT INCIDENTS</u> 8	
<u>APPENDIX "D" - FLYING WING TYPE AIRCRAFT</u> . . . . .	17
Germany . . . . .	17
Great Britain . . . . .	21
United States . . . . .	23

~~TOP SECRET~~

The Mutual UFO Network, Inc. is exempt from Federal Income Tax under Section 501(c)(3) of the Internal Revenue Code. MUFON is a publicly supported organization of the type described in Section 509(a)(2). Donors may deduct contributions from their Federal income tax. In addition, bequests, legacies, devises, transfers, or gifts are deductible for Federal estate and gift tax purposes if they meet the applicable provisions of Sections 2055, 2106, and 2522 of the code.

The contents of the MUFON UFO JOURNAL are determined by the editor, and do not necessarily represent the official position of MUFON. Opinions of contributors are their own, and do not necessarily reflect those of the editor, the staff, or MUFON. Articles may be forwarded directly to MUFON. Responses to published articles may be in a Letter to the Editor (up to about 400 words) or in a short article (up to about 2,000 words). Thereafter, the "50% rule" is applied: the article author may reply but will be allowed half the wordage used in the response; the responder may answer the author but will be allowed half the wordage used in the author's reply, etc. All submissions are subject to editing for style, clarity, and conciseness. Permission is hereby granted to quote from this issue provided not more than 200 words are quoted from any one article, the author of the article is given credit, and the statement "Copyright 1985 by the Mutual UFO Network, 103 Oldtowne Rd., Seguin, Texas" is included.

# AIR INTELLIGENCE REPORT NO. 100-203-79

By Walt Andrus

The relatively close publication dates between the noteworthy *Estimate of the Situation* produced by Project Sign and *Air Intelligence Report No. 100-203-79* dated 10 December 1948 and declassified on 5 March 1985 from TOP SECRET, makes the latter one of the most important documents recently released under the Freedom of Information ACT (FOIA). We are indebted to Robert Todd for his diligent work in obtaining this valuable document and to Peter A. Gersten for providing a copy to MUFON.

## RUPPELT

A brief review of the historical document titled *Estimate of the Situation*, classified TOP SECRET, is in order, especially for those who may be relatively new to ufology. Probably one of the most reliable sources is Edward J. Ruppelt, former head of the Air Force Project Blue Book as related in his book, *The Report on Unidentified Flying Objects* (Doubleday, 1956). Quoting from page 41: "In intelligence, if you have something to say about some vital problem you write a report that is known as an 'Estimate of the Situation.' A few days after the DC-3 was buzzed (Eastern Air Lines pilots Chiles and Whitted, July 24, 1948), the people at ATIC (Air Technical Intelligence Center, Wright-Patterson AFB, Dayton Ohio) decided that the time had arrived to make an Estimate of the Situation. The situation was the UFO's the estimate was that they were interplanetary!"

## EVOLUTION

After the estimate was completed, typed and approved, it started up through channels to higher level echelons. When the Top Secret Estimate of the Situation reached the higher echelons of the Air Force, it got to the late General Hoyt S. Vandenberg, then Chief of Staff, before it was batted back down. The general wouldn't buy interplanetary vehicles, saying the report lacked proof. The estimate died a quick death. Some months later it was completely declassified and relegated to the incinerator. A few copies were kept as

momentos of the golden days of UFOs. Captain Ruppelt saw one of these copies which he described as a thick document with a black cover and printed on legal-size paper. Stamped across the front were the words TOP SECRET.

## GORMAN

In studying Project Sign's *Air Intelligence Report No. 100-203-79*, some of the identical UFO sightings are reported that Ruppelt relates in his book as appearing in the "Estimate." The publishing date for the Estimate of the Situation was late Summer or early Fall, since it preceded Lt. George F. Gorman's dogfight with a lighted object over the airport at Fargo, North Dakota on October 1, 1948 (one of the classic cases of that era). Prior to Mr. Gorman's death, he lived in New Braunfels, Texas, only 14 miles from MUFON headquarters. My wife and I have had the pleasure of sharing his UFO experience over dinner on a few occasions. George was far from being convinced that he had been dueling with a lighted balloon for 27 minutes as the Air Force ultimately decided. His wife said he was "white as a sheet" when he arrived home a few minutes later after his harrowing encounter.

## SIGNIFICANCE

The vital significance of Report No. 100-203-79 may be attributed to the evaluation of the UFO phenomenon as known in 1948 and the technical possibility that German scientists in Soviet Russia (U.S.S.R.) had developed and perfected a craft with the flight characteristics of a UFO after World War II. It is not surprising that ATIC personnel proposed that saucers were interplanetary in origin in their Estimate of the Situation.

## ACTION

We are extremely fortunate that Report No. 100-203-79 did not suffer the same fate as the Situation by being destroyed. Two documents, declassified on January 29, 1985 and stamped CONFIDENTIAL, disclosed the designated action to be taken

regarding this report.

1. Memo dated 11 August 1950 to CG, Alaskan Air Command from AFOIV-TC; Subject: Downgrading of Air Intelligence Report No. 100-203-79. The response: Subject document, for which your Command requests downgrading action, contains info and speculation on the "flying saucer" situation which have never been released or intimated publicly by the Air Force.
2. Memo dated 25 September 1950 from Dept. of the Air Force Hqs. U.S. Air Force. Subject: Destruction of Air Intelligence Report Number 100-203-79. The instructions were: It is requested that action be taken to destroy all copies of Top Secret Air Intelligence Report Number 100-203-79, subject "Analysis of Flying Object Incidents in the U.S.," dated 10 Dec 1948. It was filed under: 313.6 Records, Destruction of 17 Oct 50.

If the instructions had been followed explicitly, this report would have been destroyed. Will the FOIA requests being initiated recover a copy of the Estimate of the Situation that Captain Ruppelt saw in the Air Force file?

## EDITING

The original copy of the report from the Directorate of Intelligence Headquarters United States Air Force and the Office of Naval Intelligence Navy Department contains 26 pages plus a cover and index. The copies of the photographs were of such poor quality that they have not been reproduced in this issue of the Journal. After extracting the majority of the UFO photographs, and flying wing-type aircraft, the 26 pages were edited physically so as to retain the text of the report. Two photographs of flying-wing aircraft were substituted for the original rough copies for the benefit of Journal readers (YRB-49A and XF5U-1).

It is unusual for MUFON to devote a monthly issue to one specific article or report. The editors feel that the significance of this report warrants maximum exposure.

ANALYSIS OF FLYING OBJECT INCIDENTS IN THE U. S.

SUMMARY AND CONCLUSIONS

PROBLEM

1. TO EXAMINE pattern of tactics of "Flying Saucers" (hereinafter referred to as flying objects) and to develop conclusions as to the possibility of existence.

FACTS AND DISCUSSION

2. A DETAILED discussion of information bearing on the problem as set forth above is attached as Appendix "A". The main points established therein are summarized below.

3. THE FREQUENCY of reported incidents, the similarity in many of the characteristics attributed to the observed objects and the quality of observers considered as a whole, support the contention that some type of flying object has been observed. Approximately 210 incidents have been reported. Among the observers reporting on such incidents are trained and experienced U.S. Weather Bureau personnel, USAF rated officers, experienced civilian pilots, technicians associated with various research projects and technicians employed by commercial airlines.

4. THE POSSIBILITY that reported observations of flying objects over the U.S. were influenced by previous sightings of unidentified phenomena in Europe, particularly over Scandinavia in 1946, and that the observers reporting such incidents may have been interested in obtaining personal publicity have been considered as possible explanations. However, these possibilities seem to be improbable when certain selected reports such as the one from U.S. Weather Bureau at Richmond are examined. During observations of weather balloons at the Richmond Bureau, one well trained observer has sighted strange metallic disks on three occasions and another observer has sighted a similar object on one occasion. The last observation of unidentified objects was in April, 1947. On all four occasions the weather balloon and the unidentified objects were in view through the theodolite. These observations at the Richmond Bureau occurred several months before publicity on the flying saucers appeared in a U.S. newspaper.

5. DESCRIPTIONS OF the flying objects fall into three configuration categories: (1) disk-shaped (2) rough cigar-shaped (3) balls of fire. Varying conditions of visibility and differences in angles at which the objects may have been viewed introduces a possibility that a single type object may have been observed rather than three different types. This possibility is further substantiated by the fact that in the areas where such objects have been observed the ratio of the three general configurations is approximately the same.

6. THEREFORE, IT appears that some object has been seen; however, the identification of that object cannot be readily accomplished on the basis of information reported on each incident. It is possible that the object, or objects, may have been domestically launched devices such as weather balloons, rockets, experimental flying wing aircraft, or celestial phenomena. It is necessary to obtain information on such domestic activity to confirm or deny this possibility. Depending upon the degree with which this may be accomplished, foreign devices must then be considered as a possibility.

7. THE PATTERN of sightings is definable. Sightings have been most intense throughout the states bordering the Atlantic and Pacific coast lines, and the central states of Ohio and Kentucky. A map showing location of sightings is attached as Appendix "B".

8. THE ORIGIN of the devices is not ascertainable. There are two reasonable possibilities: (1) The objects are domestic devices, and if so, their identification or origin can be established by a survey of all launchings of airborne objects. Domestic flying wing type aircraft observed in various aspects of flight might be responsible for some of the reported flying objects, particularly those described as disks and rough cigar shapes. (See Appendices "C" and "D".) Among those which have been operational in recent years are the XP5U-1 ("Flying Flapjack") developed by Chance-Vaught, the Northrup B-35, and the turbo-jet powered Northrup YB-49. The present existence of any privately developed flying-wing type aircraft has not been determined but one such aircraft, the Arup tailless monoplane, was operational at South Bend, Indiana, prior to 1935. (2) Objects are foreign, and if so, it would seem most logical to consider that they are from a Soviet source. The Soviets possess information on a number of German flying-wing type aircraft such as the Gotha P60A, Junkers EF 130 long-range, high-speed jet bomber and the Horten 229 twin-jet fighter, which particularly resembles some of the description of unidentified flying objects (See Appendix "D"). As early as 1924 Tscheranowsky developed a "Parabola" aircraft, an all wing design, which was the outcome of considerable Soviet experimentation with gliders of the same general form. Soviet aircraft based on such designs might have speeds approaching trans-sonic speeds attributed to some flying objects or greater over-all performance assuming the successful development of some unusual propulsion device such as atomic energy engine.

9. THAT THE Soviets have a current interest in flying-wing type aircraft is suggested by their utilization of Dr. Guenther Bock who, at the end of World War II, was in charge of the flying-wing program in Germany (See Appendix "A", paragraph 3, page 4). Achievements satisfactory to the U.S.S.R. are indirectly indicated by the personal recognition he is reported to be receiving in the U.S.S.R. Recently it has been reported that the U.S.S.R. is planning to build a fleet of 1,800 Horten flying-wing aircraft. Information of low evaluation has been received stating that a regiment of jet night fighters, Model Horten XIII, is at Kuzmikka, an air base two miles southwest of Irkutsk. Kuzmikka is identified as one of a number of airfields for the protection of an atomic energy plant at Irkutsk. The Horten XIII as developed by Germany was a glider.

10. ASSUMING THAT the objects might eventually be identified as foreign or foreign-sponsored devices, the possible reason for their appearance over the U.S. requires consideration. Several possible explanations appear noteworthy, viz:

- a. To negate U.S. confidence in the atom bomb as the most advanced and decisive weapon in warfare.
- b. To perform photographic reconnaissance missions.
- c. To test U. S. air defenses.
- d. To conduct familiarization flights over U.S. territory.

#### CONCLUSIONS

11. SINCE the Air Force is responsible for control of the air in the defense of the U.S., it is imperative that all other agencies cooperate in confirming or denying the possibility that these objects have a domestic origin. Otherwise, if it is firmly indicated that there is no domestic explanation, the objects are a threat and warrant more active efforts of identification and interception.

12. IT MUST be accepted that some type of flying objects have been observed, although their identification and origin are not discernable. In the interest of national defense it would be unwise to overlook the possibility that some of these objects may be of foreign origin.

APPENDIX "A"

ANALYSIS OF FLYING OBJECT INCIDENTS IN THE U. S.  
AND HYPOTHETICAL TACTICS EMPLOYED

1. INTRODUCTION. To formulate the possible tactics of flying objects reported over the U. S. assumes from the outset that firm conclusions have been reached on both the existence and origin of the reported flying objects. The current status of information on such incidents and over-all analysis does not allow substantiation for such conclusions. However, the lack of such firm conclusions points to the necessity for an immediate and sound statistical analysis of every aspect of the situation and does not preclude a concurrent examination of the reported incidents to develop explanations of their possible tactics. The latter will be useful at some future date should the existence and origin of the flying objects be definitely established. Therefore, the following analysis of available information is advanced in order to present evidence on the actual existence of some type flying object and to relate same to tactical purposes for which the objects are possibly designed. The following discussion must be considered a provisional analysis, pending a further detailed analysis of all aspects of the problem.

2. SOME ASPECTS REGARDING FLYING OBJECT INCIDENTS. A cursory examination of evidence on reported incidents has been made and it is possible to cite certain generalities which it appears may be borne out when detailed analyses have been completed.

Among the incidents reported there are many statements by reliable and experienced persons which tend to confirm that flying objects have been seen. The description of such objects seems to fall roughly into three categories: (1) Silver disks or balls, approximating a Horten wing type aircraft; (2) Balls of fire of various colors and intensities; (3) Cigar or pencil-shaped objects similar in appearance to V-2 type rockets in horizontal flight. The numbers of configurations might be further reduced with the following considerations in mind: Silver disks or balls have, for the greater part, been observed in daylight and a number under clear weather conditions with visibility unlimited. In most instances, balls of fire have been observed at night. Cigar, or pencil-shaped objects have been sighted in fewer numbers but with about equal distribution in daylight and at night. A few accounts tell of the disks having a rough cigar-shape when viewed while maneuvering. Some of the disks are described as having luminosity in daylight. It therefore is possible that a single type of object may be involved in all sightings, and differences in description may result from viewing the objects at various angles and under differing conditions of visibility.

The above tends to indicate that some type object has been seen and the possibility exists that the object or objects seen are conventional domestic devices, such as weather balloons, test rockets, or jet-equipped aircraft with pancake or flying wing configurations.

The possibility exists that the reporting of flying objects may have been influenced by earlier reports on similar incidents in Scandinavia and Central Europe. The publication in newspaper of details on such incidents, both foreign and domestic, may have induced some of the description provided in reported domestic incidents. However, one of the earliest reported sightings in the U.S. was the one observed by U.S. Weather Bureau personnel in April 1947, at Richmond, Virginia, and on the basis of this one report it appears that the disks are not balloons. It would seem that this sighting was not influenced by the reports of foreign incidents, the newspaper accounts of domestic incidents, nor by misidentification of a conventional object.

Although reported domestic incidents are widely scattered throughout the U.S., frequency of sighting and number of observers per sighting assumes a definable pattern. There is a large concentration of sightings along the Eastern Seaboard; another large concentration throughout the Western Coast states, and a few sightings in the Middle West. Distribution of incidents by configuration of object and description of maneuverability is approximately equal in each of these areas and this is believed to further substantiate the possibility that one type of object might have been observed in different aspects of flight.

If sightings are induced by rumor, it seems unusual that more incidents have not been reported from the areas with high concentration of population. Reports from such areas would also have greater facility in channelling either to newspaper or official reporting agencies. For the most part, sightings have been made in fairly open country where there are few restrictions to visibility, which may indicate that obstructed vision has reduced sightings in built-up areas.

It therefore seems that some type of flying object has been observed, the identification of its origin requires the completion of other analyses.

3. POSSIBLE ORIGIN OF UNUSUAL FLYING OBJECTS. Provided, upon the completion of analyses, it is indicated that some or all of the reported flying objects over the U.S. are of foreign origin, the objects could from a logical viewpoint, be considered Soviet. It is evident from the performance characteristics attributed to the unidentified objects at this time that if they are foreign, they involve efficiencies of performance which have not been realized in any operational airborne device in this country. It would, therefore, be a mistake to analyze the technical aspects of the situation within the limits of our own knowledge of practical developments. It is more desirable to consider then the outer limits of possible Soviet developments and objectives in attempting to formulate some idea of the tactics which might be involved.

First of all, the scientific objectives of the U.S.S.R. have been stated many times and indicated in many forms. The most clearcut statement of this objective is probably the one contained in the preamble to the Fourth Five-year Plan (1946-1950) which states that the objective of Soviet science is to overtake and surpass the scientific and technical developments of the capitalist nations. It apparently would be an impossible task for the Soviet Union to accomplish such an objective by proceeding step-by-step along the same lines of development already achieved in the capitalist nations. This would mean that it would be necessary to rapidly proceed through each phase of aeronautical development that has already been accomplished in this country, and this probably would never have any prospects of accelerating Soviet development beyond any point reached by the U.S. The obvious answer to accomplish their objective of not only overtaking, but surpassing the capitalist countries would be a scientific shortcut. This possibility is not so remote when examined on the basis of our knowledge of the current situation in the U.S.S.R. Provided Soviet emphasis was given to the most promising and advanced ideas acquired from Germany in 1945 and the work aided by German scientists, the possibility of catching up and possibly surpassing other nations in technical developments becomes more realistic. It becomes even more realistic if the Soviets have shown a tendency to concentrate on certain developments which have still not received a maximum of priority in our own programs.

It is known that the U.S.S.R. has since 1945 enlisted the services of Dr. Guenther Bock, a German who headed all development of low aspect ratio (flying wing) type aircraft in Germany. Dr. Bock is believed to be the top German scientist in charge at TSAGI and TSIAM which are "Air Material Command" type organizations in the U.S.S.R. Further, it is believed that Dr. Bock has made available all German plans for flying wing type aircraft to the Soviets. Among the designs considered by the Germans and possibly exploited by the U.S.S.R., are jet-propelled, flying wing type aircraft whose configuration would be similar to descriptions of certain objects reported flying over the U.S. The estimated speeds of such aircraft are within range of the lower limits of speed attributed to flying objects over the U.S. It is not impossible that emphasis on surpassing foreign developments has led to unusual progress in fuels and propulsion by the U.S.S.R. In connection with possible advancements in the field of fuels and propulsion, it should be observed that

the Russian oil situation (regardless of estimated oil reserves) is quite different from that in the U.S. For example, U.S. oil industry is prepared to turn out tremendous quantities of highly fractionated petroleum products, while the U.S.S.R. cannot reasonably approach such capabilities. This consideration dictates different solutions on fuels for propulsion in the two countries and in turn, dictates the direction taken in development of jet motors or the use of other propulsive devices. We must therefore, arrive at the conclusion that any Soviet device which may have made its appearance over the U.S. as described, would possess unusual performance characteristics which, in all probability, would include unusual range. The possibility that they could have been launched at fairly close range should not be discarded.

4. POSSIBLE REASONS OR TACTICS FOR THE USE OF SOVIET UNCONVENTIONAL AIRCRAFT OVER THE U.S. Predicated on all the foregoing assumptions, Soviet unconventional aircraft may have been flown over the U.S. for one, all, or a combination of the following reasons:

a. TO NEGATE U.S. CONFIDENCE IN ATOM BOMB AS THE MOST ADVANCED AND DECISIVE WEAPON. If the objects have been used in a propaganda sense, it would be reasonable to assume that the Soviets would choose first to frighten pro-American nations in Europe with the appearance of a radically new weapon to counteract the ability of the U.S. to obtain full propaganda effectiveness with the atom bomb. It will be remembered that strange objects first appeared over the Scandinavian countries in 1946. The objects observed there had unusual range and unusual performance characteristics. As this demonstration over the Scandinavian countries occurred the U.S. was making a vigorous campaign for the economic and political alignment of these nations with other pro-American Western European nations. When these incidents subsided, strange flying objects began to be observed at an increasing rate over the U.S. The conclusion on this point is that flying objects may have been used to frighten both European nations and the U.S. by the appearance of a new device, and that failure to identify such a Soviet object would give them invaluable indication that U.S. development is far behind that of the Soviets. Except for this indication, it is believed that the use of the objects to promote fear has been worthless in that the U.S. public has tended to characterize these incidents entirely as hallucinations by "crack pots", misidentification of conventional objects, or that they represent a secret American project which should not be publicized. Any fear that might result from Soviet use will come only by a discovery that the objects have been Soviet aircraft and that they involve radical developments which are in advance of our own accomplishments.

b. FOR PHOTOGRAPHIC RECONNAISSANCE. It is possible that the Soviets have employed the flying objects for the collection of photographic intelligence or the mapping of certain areas in the U.S. The evasive action employed by all objects sighted indicates not so much an attempt to avoid being sighted, as an attempt to prevent disclosure of the exact type of flying craft and its mission. The sighting of objects over the U.S. has been most intense in Eastern and Western Coastal States. In addition, sightings of flying objects have been made near Oak Ridge, Tenn., Las Cruces, N. M., and in the general area of the Hanford Works in Oregon. Generally, sightings have not been made over what we consider strategic industrial areas. The reason for this might be either that the flying objects have been observed only enroute to or from missions over these more concentrated strategic areas, or that the Soviets obtained sufficient information during their World War II liaison with U.S. industry to satisfy their intelligence requirements and have a more active requirement for information on industries and areas which were not available to them during World War II contacts. This is of interest in connection with the sightings near Oak Ridge, Las Cruces, and in the general area of the Hanford Works since these establishments were not, and are not, accessible to Soviet collectors of photographic intelligence.

c. TEST OF U. S. DEFENSES. It is possible that the use of Soviet flying objects over the U.S. is intended only to determine the ability of the U.S. defenses to spot foreign aircraft. This would be of extreme importance to the U.S.S.R. in the event that a one-way all-out attack of Soviet strategic bombers is planned. Ability to operate over the U.S. uninhibited at a time when the U. S. is supposedly re-arming and putting great stress on defenses would provide valuable information on which to base estimates for probability of success in bombing strategic objectives in the U. S.

d. FAMILIARIZATION FLIGHTS OVER U.S. TERRITORY. This possible reason is perhaps the most improbable. It is assumed that, should this purpose be involved, other purposes are probably also accomplished in its execution. Provided the U.S.S.R. has unusually high performance aircraft they might find it advantageous to familiarize themselves with the topography of the U.S. in anticipation of future combat missions to strategic targets.

5. CONCLUSION. The conclusion that some type of flying object has been observed over the U.S. seems to be substantiated. It is not known at this time whether these observations are misidentifications of domestically launched devices, natural phenomena, or foreign unconventional aircraft. It is, therefore, impossible to make any reliable explanation for their appearance over the U.S. or the tactics which they may employ if the objects observed include any foreign developments in aeronautical fields. It is likewise impossible at this time to contain discussions of possible performance characteristics or tactics within limits of practical reason, if for no other reason than the fact that proof of the existence of a foreign development of this type would necessarily introduce considerations of new principals and means not yet considered practical possibilities in our own research and development.

~~CONFIDENTIAL~~

APPENDIX "B"

REPORTED SIGHTINGS OF FLYING OBJECTS

AS OF 1 AUGUST 1948

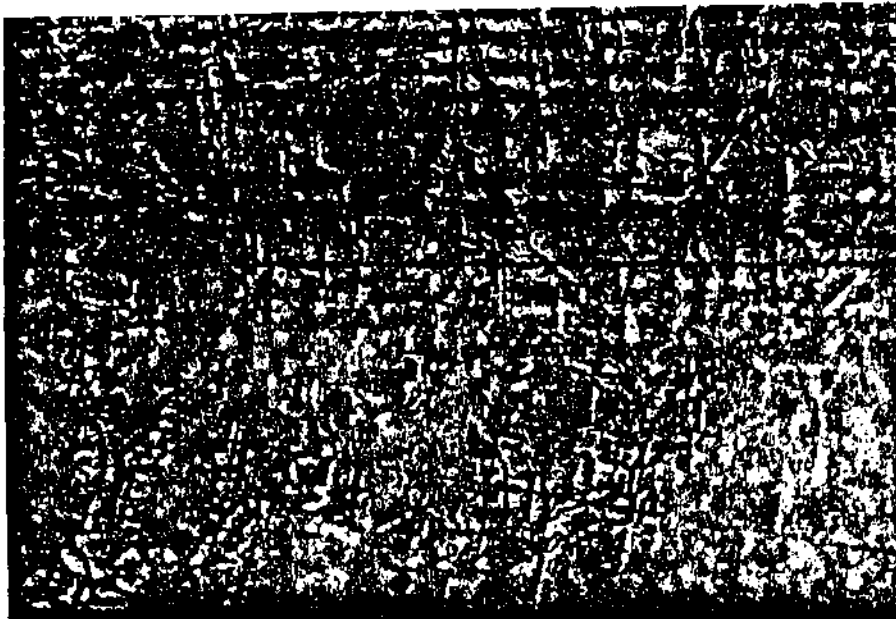

Map of the U.S.A. with sighting locations  
(Not legible on FOIA copy)

~~CONFIDENTIAL~~

- 7 -

APPENDIX "C"

SELECTED REPORTS OF FLYING OBJECT INCIDENTS

1. A NUMBER of reports on unidentified flying objects come from observers who, because of their technical background and experience do not appear to be influenced by unfounded sensationalism nor inclined to report explainable phenomena as new types of airborne devices. Some of the details of their reports are presented in this appendix, along with those from possibly less reliable sources who have reported evidence which is of such a nature that it cannot be entirely ignored.

2. DESCRIPTIONS OF significant incidents, arranged chronologically, follow:

a. During April 1947, two employees of the Weather Bureau Station at Richmond, Virginia reported seeing a strange metallic disk on three occasions through the theodolite while making PIBAL observations. One observation was at 16,000 feet when a disk was followed for 15 seconds. The disk appeared metallic, shaped something like an ellipse with a flat bottom and a round top. It appeared below the balloon and was much larger in size. The disk appeared to be moving rather rapidly, although it was impossible to estimate its speed. The other observations were made at 27,000 feet in like manner.

b. The following month, [redacted] a field engineer for Radio Corporation of America, reported a disk flying near his home in Oklahoma City, Oklahoma. The object was thought to be at an altitude between 10,000 feet and 18,000 feet, and was moving toward the north at a high rate of speed, leaving no trailing effects.

c. While flying at 10,000 feet on a course of 300 degrees, 30 miles northwest of Lake Meade, Nevada, an Air Force lieutenant reported seeing five or six white circular objects in close formation and traveling at an estimated speed of 285 miles per hour. This sighting occurred on 28 June 1947.

4. The following day a party of three, two of them scientists, were motoring along Highway 17 toward the White Sand, New Mexico, V-2 firing grounds and reported seeing a large disk or sphere moving horizontally at a high speed and an estimated altitude of 10,000 feet. It was of uniform shape and had no protruding surfaces such as wings. The object was in sight for about 60 seconds before it disappeared to the northeast. The three observers agreed on the details of the sighting except that one thought he had seen vapor trails.

e. On 7 July 1947, five Portland, Oregon police officers reported varying numbers of disks flying over different parts of the city. All observations were made within a minute or two of 1305 hours.

f. On the same day, [redacted] of Phoenix, Arizona allegedly saw a disk circling his locality during sunset and took two photographs. The resulting pictures (page 9) show a disk-like object with a round front and a square tail in plan form. These photographs have been examined by experts who state they are true photographic images and do not appear to be imperfection in the emulsion or imperfections in the lens. (See Figs. 1, 2, 3 and 4.)

Figures 1, 2, 3 and 4 not legible on copy

~~SECRET~~

g. On 10 July 1947, Mr. [redacted] a Pan-American Airways mechanic reported a circular object flying at high velocity, paralleling the earth's surface and leaving a trail which appeared as a "burning up" of the cloud formation. The sighting occurred near Harmon Field, Newfoundland. Two other persons also saw the trail which remained in the sky for about an hour and was photographed by another PAA employee. The resulting photographs support Mr. Woodruff's observation as far as the sky cleavage is concerned. (See Figs. 5 and 6.)



Fig. 5

- 10 -



Fig. 6

h. On 29 July 1947, [redacted] while flying near Tacoma, Washington, reported a formation of flying objects. His sketch of their shape corresponds closely to that shown in the photographs made by Mr. [redacted]. On the same day, two U. S. Air Force pilots at Hamilton Field reported two flying disks trailing a P-80, following it toward Oakland, California.

i. On 4 August 1947, the pilot and co-pilot of a DC-3, flying for one Al Jones, near Bethel, Alaska, reported a flying disk larger than their aircraft. This disk crossed their path at about 1,000 feet and they turned to give chase. The DC-3 was flying at 170 mph, but the disk flew out of sight in four minutes.

j. On 12 November 1947, two flying disks trailing jet-like streams of fire were reportedly sighted from the bridge of the tanker Ticonderoga, according to the second officer. The Ticonderoga was 20 miles off the Oregon shore. This officer said the disks were in sight 45 seconds, moving at a speed estimated at 700-900 mph, curving in a long, low arc.

~~SECRET~~

- 11 -

11

k. On 7 January 1948, a National Guard pilot was killed while attempting to chase an unidentified object up to 30,000 feet. While it is presumed that this pilot suffered anoxia, resulting in his crash, his last message to the tower was, "It appears to be metallic object....of tremendous size....directly ahead and slightly above....I am trying to close for a better look."

l. On 6 April 1948, three trained balloon observers from the Geophysics Laboratory Section, Watson Laboratories, N.J. reported seeing a round, indistinct object in the vicinity of Holloman Air Force Base, New Mexico. It was very high and fast, and appeared to execute violent maneuvers at high speed. The object was under observation for approximately 30 seconds and disappeared suddenly.

m. A yellow or light colored sphere, 25 to 40 feet in diameter was reported by Lt. Comdr. Marcus L. Lowe, USN, just south of Anacostia Naval Air Station, D.C., while he was flying on 30 April 1948. It was moving at a speed of approximately 100 miles per hour at an altitude of about 4,500 feet. Although winds aloft were from the north-northwest, its course was to the north.

n. On 1 July 1948, twelve disks were reported over the Rapid City Air Base by Major Hammer. These disks were oval-shaped, about 100 feet long, flying at a speed estimated to be in excess of 500 mph. Descending from 10,000 feet, these disks made a 30-degree to 40-degree climbing turn accelerating very rapidly until out of sight.

o. On 17 July 1948, a report from Kirtland Air Force Base describes a sighting in the vicinity of San Acacia, New Mexico, of seven unidentified objects flying in a "j" formation at an estimated height of 20,000 feet above the terrain. The formation varied from "j" to "L" to circle after passing the zenith. Flashes from the objects were observed after passing 30 degrees beyond the zenith but there was no smoke or vapor trail. If the reported altitude is correct the speed was estimated at 1,500 miles per hour, according to the report.

p. Other sightings of lights and trails, rather than disks, have been reported, viz:

(1) On 12 September 1947, the pilot and co-pilot of a Pan American aircraft, en route from Midway to Honolulu, saw a blue-white light approaching, changing to twin reddish glows upon withdrawal. The pilot estimated the speed of the light at about 1,000 knots.

(2) On 15 June 1948, Mr. ██████████ territory manager for the B.F. Goodrich Company, observed a reddish glow with a jet exhaust in the vicinity of Miles City, Montana. This glowing light made no sound, traveled about twice the speed of a conventional aircraft and flew from north to south several times in a wide arc, finally disappearing over the horizon.

q. During the early morning of 25 July 1948, two Eastern Airlines pilots reported having seen a huge flying craft similar to a V-2 pass their aircraft in flight. (See Figs. 7 and 8.) The attached drawings made by these two observers very closely resemble a flying object reported to have been seen on 20 July 1948, by ██████████, chief investigator of Court of Damage Inquiry, and his daughter at Arnham, Netherlands. This object appeared to be a wingless aircraft having two decks. The craft, sighted four times through scattered clouds and unlimited visibility, was traveling at high speed at a high altitude. A sound similar to that made by a V-2 was reported.

r. An object, similar in shape to the one in the preceding incident was reported by an experienced American newspaper reporter about 25 kilometers northeast of Moscow on 3 August 1948. A Russian acquaintance identified it as a rigid airship but the reporter disagrees because it flew at a high, but not excessive speed.

s. On 1 October 1948 at approximately 2030 hours the pilot of a F-51 aircraft, 2nd Lt. George F. Gorman (North Dakota Air National Guard), flying near Fargo, North Dakota, sighted an intermittent white light about 3,000 feet below his 4,500 feet cruising altitude. The pilot pursued the light which appeared to then take evasive tactics. The object or light out-turned, out-speeded, and out-climbed the F-51 in every instance during the attempt to intercept. The pilot lost contact 27

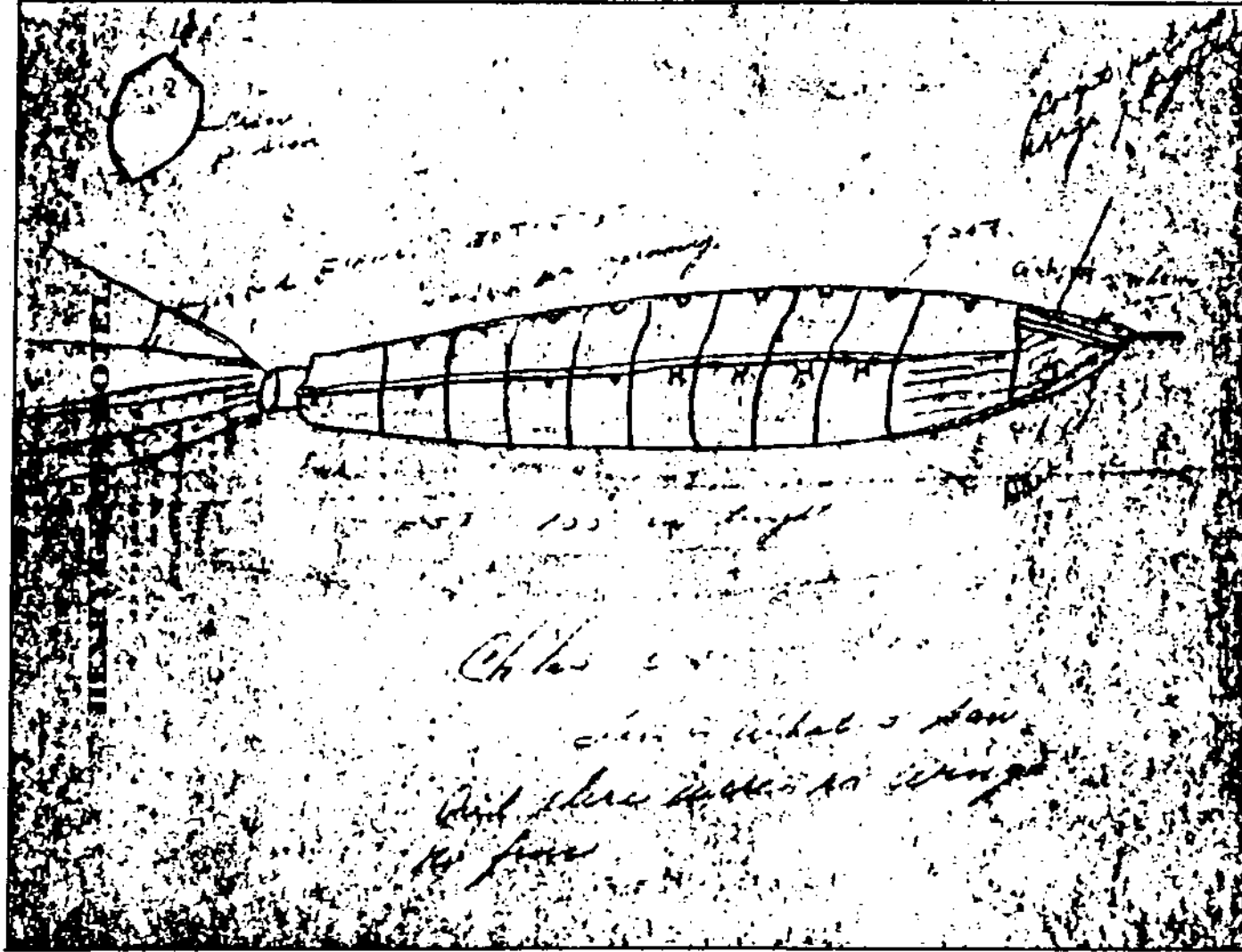
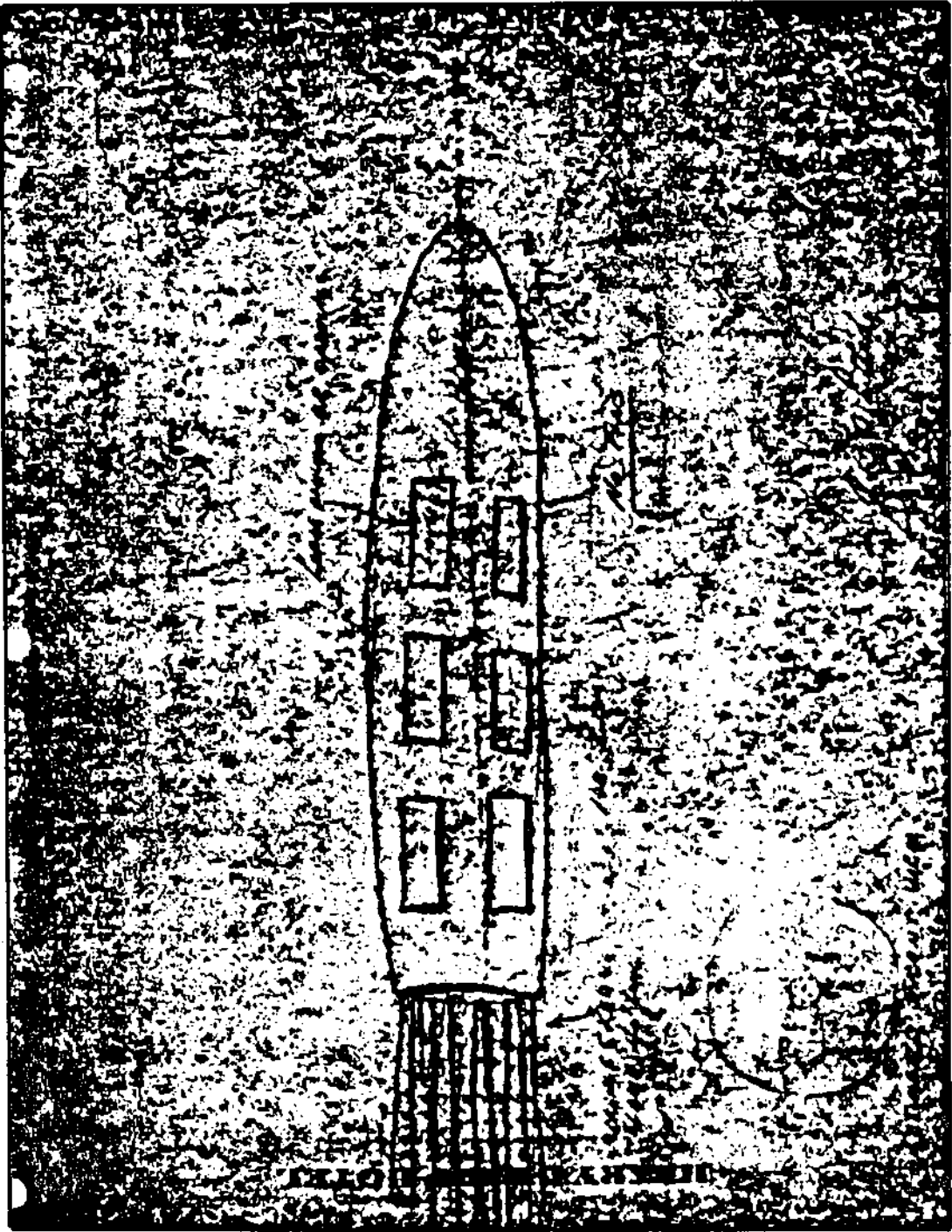

FIG. 7

~~SECRET~~

Fig. 8



~~SECRET~~

minutes after the initial sighting. The same light was observed by three other witnesses from the ground: Mr. [REDACTED], Air Traffic Controller, Mr. [REDACTED] Assistant Traffic Controller, and Dr. [REDACTED], Oculist. A comparison of all testimony revealed that one object was sighted and that it consisted only of a small round ball of clear white light with no apparent shape attached. It was about 6 to 8 inches in diameter. At times it traveled faster than the F-51 and performed maneuvers in an evasive manner. When first sighted the ball of light was traveling at an estimated 250 miles per hour. Under this condition, the light was not continuous but blinked off and on. At high performance the white light was continuous. Subsequent investigation eliminated the possibility that this incident may have been another aircraft or a meteorological balloon.

1. On 18 November 1948 at approximately 2145 hours, three reserve pilots, 2nd Lt. Kenwood W. Jackson, 2nd Lt. Glen L. Stalker, and 2nd Lt. Henry G. Combs, flying near Andrews Field, Maryland, encountered an unidentified flying object. When first sighted, it appeared to be lighted and flying at about 1,700 feet. Three or four passes were made in an attempt to identify it. The pilot of the aircraft stated that while diving his aircraft at approximately 240 miles per hour, the object would climb vertically and then would drop below the aircraft from behind and continue to circle. On the last pass, the landing light was switched on and momentarily a dull gray glow from the object was observed. Lt. Combs stated he maintained contact for about ten minutes with the object flying between the lights of Washington, D. C. and his aircraft. All that could be observed was an oblong ball with one light, no wings and no exhaust flame. It finally made a very tight turn and headed toward the east coast at an estimated 500 to 600 miles per hour. At the same time Staff Sergeant John J. Kushner observed from the ground an unusual object in the air over Andrews Field. He stated that it was not very high and that it did not look like an aircraft.

3. REPORTS OF radar intercepts point to unusual air activity which may be related to flying objects.

a. On 1 July 1947, a GCA radar at Hokkaido, Japan picked up an unidentified target at 16 miles, with a speed in excess of 500 mph. This target split into two targets, each estimated to be larger than a P-51.

b. On 16 September 1947, an MEW radar at Fukuoka, Japan, picked up a target at 89 miles and trailed it to 19 miles, where it faded. Speed was 840-900 mph. The speed measurement, made by a good crew through a 70-mile track, is believed accurate.

4. Investigations conducted by Headquarters, Air Materiel Command, have definitely established the identification of 16 of approximately 210 so-called flying saucers which have been reported. Approximately nine per cent of the total number of incidents are, therefore, eliminated from further specific consideration. Among those incidents positively explained, three were hoaxes, two were from unreliable witnesses. In the remaining 13 eliminated incidents, objects were actually seen but investigation has shown that they were celestial bodies or phenomena, meteorological and carnival balloons, and airborne cosmic ray experimental equipment. The following examples are presented for comparison of the information reported by witnesses and true identification of the object involved:

a. On 22 July 1948, Captain Henry Glover (Ordnance Reserve) and his wife observed at Van Nuys, California, an object which they were unable to positively identify. Object at first appeared to be round and looked like a weather balloon at about 2,000 feet but there was no characteristic bobbing. The wind was blowing on the ground but the object was quite steady. During the time it was under observation, about an hour, it traveled through a vertical arc of about twenty-five (25°) degrees or more. The observer concluded that it was not a celestial body. It has a bluish luminescence and as the sun set, the object's color gradually changed to orange at dusk and ceased to be illuminated almost instantaneously. The outline was clear and the air was clear with visibility unlimited. The object traveled from the east to the west.

This object was determined by investigation to have been a balloon carrying cosmic ray equipment.

b. On 14 August 1948, at approximately 1050 hours an unidentified flying object was visible from the ground at Godman Air Force Base, Kentucky. This object was estimated to be at about 30,000 to 40,000 feet altitude, spherical in shape, bright silver color and gave a bright reflection from the sun. An F-51 was dispatched from Standiford Air Force Base, Kentucky, to observe the object. During observation from the ground, there was no change in the elevation of the object and it seemed to be moving southwest from Godman Air Force Base. The F-51 which was flying over Godman AFB at an altitude of 30,000 to 35,000 feet reported that it was unable to locate the object although it was still visible from the ground with the naked eye. Azimuth and elevation readings were taken by theodolite every minute and the path of the object was charted.

The object was determined to be the planet Venus by Mr. Moore, the head astronomer at the University of Louisville, Louisville, Kentucky. It is believed that earlier incidents at Godman Field (reference paragraph 2k, page 12, Appendix "C") may also have been observations of the planet Venus.

5. AMONG THOSE incidents still not positively explained, reported observations differ to some extent, but three general categories of sightings emerge -- the flying disk, the ball of fire and the large jet rocket. Interesting observations that were noted are:

a. Most of the objects are a thin disk, round on top and flat on the bottom. The front half of the disk is often circular, sweeping back to a square tail across the full width.

b. A high rate of climb as well as the apparent ability to remain motionless or hover for a considerable length of time is indicated.

c. Reported sizes have varied from that of a 25-cent piece to 250 feet in diameter, and from the size of a pursuit plane to the bulk of six B-29 airplanes.

d. Speeds have been estimated throughout the entire range from very slow or hovering to supersonic.

e. Sounds and visual trails are not normally associated with the sightings.



APPENDIX "D"

FLYING WING TYPE AIRCRAFT

1. AERONAUTICAL ENGINEERS in several countries have been engaged for some time in the design, construction, and flight of flying wing type aircraft. The study of flying objects requires, at least, a brief examination of proposed and existing unconventional aircraft whose configurations, when seen by the uninitiated, could lead to reports of strange flying devices. A description of some of the more significant types by country follows.

2. GERMANY. At the end of World War II, German aircraft designers had numerous projects under way concerning tailless aircraft which conceivably could be mistaken for "Flying Saucers" or disc-like objects. It is not clear just what the Soviets are doing in the way of developing these projects but it is considered that German studies on tailless, delta-wing, and related configurations are available to the U.S.S.R.

a. ARADO NIGHT AND BAD WEATHER FIGHTER, PROJECT I. This is a tailless, low-wing monoplane with swept-back wing of large root chord and having a long, narrow fuselage.

Span	60.3 feet
Length	42.5 feet
Power Plant	2 HeS O11 turbo jet units
Max. Speed (sea level)	441 mph
Max. Speed (29,500 feet)	503 mph

b. ARADO E 581-4. A high-wing tailless single-seater with a single jet unit mounted in the fuselage. Fin and rudder units are mounted on the wing midway between fuselage and wing tip at the trailing edge.

Span	29.3 feet
Length	18.4 feet
Power Plant	1 HeS O11 turbo jet unit
Max. Speed (sea level)	--
Max. Speed (service ceiling)	--

c. GOTHA P 60 A. This was the first of the P 60 series of jet fighters. It is a flying wing type and, since the pilot and observer lie prone, there is no projecting canopy, thus permitting a particularly clean design. The jet units are mounted at the rear of the center section, one above and one below.

Span	40 feet 8 1/2 in.
Wing Area	504 square feet
Power Plant	2 BMW 003 turbo jet units
Max. Speed (23,000 feet)	598 miles per hour

d. HEINKEL P 1080. This is a single-seat fighter with a sharply swept-back wing, resembling a flying wing type, but having a single fin and rudder with no tail plane.

Span	29.2 feet
Wing Area	218 square feet
No performance estimates are available.	

e. JUNKERS EF 130. Of the flying wing type, this project was established as a long-range, high-speed jet bomber.

Span	78.8 feet
Wing Area	1290 square feet
Power Plant	4 HeS O11 turbo jet units
Max. Speed	620 miles per hour
Range	3700 miles

~~CONFIDENTIAL~~

f. ME 329. This is a tailless mid-wing monoplane driven by two pusher propellers with the engines centrally located in the wings on each side of the stubby rounded fuselage.

Span	56 feet
Length	25.4 feet
Max. Speed	455-465 miles per hour
Power Plant	2 DB 603 reciprocating engines

g. HORTEN WING. The closest resemblance to the estimated configuration of "Flying Disks" is represented by the Horten Wing aircraft. Work on the Horten 229, a twin jet fighter, had progressed to the final stages at the end of World War II. Its prototype, a Horten glider, successfully soared to an altitude of 14,200 feet as early as 1938, proving the soundness of this design. (Figs. 1, 2 and 3)

3. GREAT BRITAIN.

a. THE ARMSTRONG WHITWORTH. The AW 52 G, a glider, and the AW 52, a twin-jet airplane, are British designs of tailless aircraft. The vertical stabilizers are located at the tips of the swept-back wing. (Figs. 4 and 5) Data on the AW 52 appear below.

Span	90 feet
Length	37 feet
Max. Speed (sea level)	435 knots
Max. Speed (20,000 feet)	436 knots
Max. Speed (36,000 feet)	417 knots
Range	1300 nautical miles
Power Plant	2 Nene II turbo jet units

4. UNITED STATES

a. NORTHROP B-35. This is a flying wing type aircraft, powered by four reciprocating engines and has a wing span of 170 feet and a length of only 53 feet. (See Fig. 6)

b. NORTHROP YB 49. Powered by eight turbo-jet engines, this airplane is the jet-propelled version of the Northrop Flying Wing (B 35). (See Fig. 7)

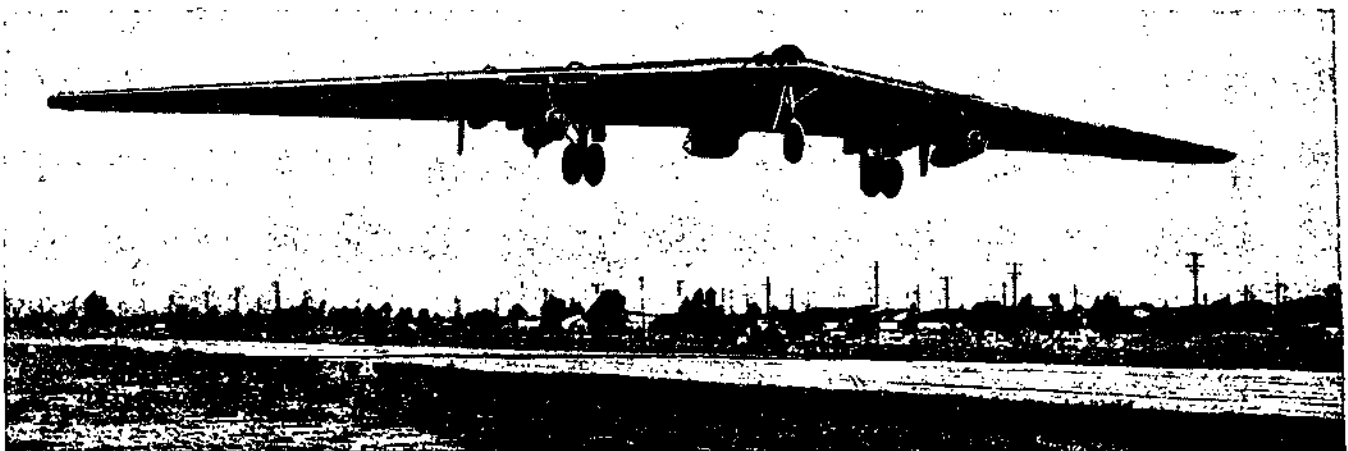

Newest Northrop flying wing is YRB-49A which features new mounting for its six jet engines. Pressurized craft is designed for photo-reconnaissance purposes, carries crew of six. It is powered by Allison J-35's, has undisclosed speed and range.

Fig. 7

c. CHANCE-VAUGHT XF5U-1. Developed by Chance-Vaught Aircraft, this radical design promises the reality of high and low speed performance. Powered by two R-2000-2 engines, the airplane will have a speed range of from 40 to 425 miles per hour. (See Fig. 8)

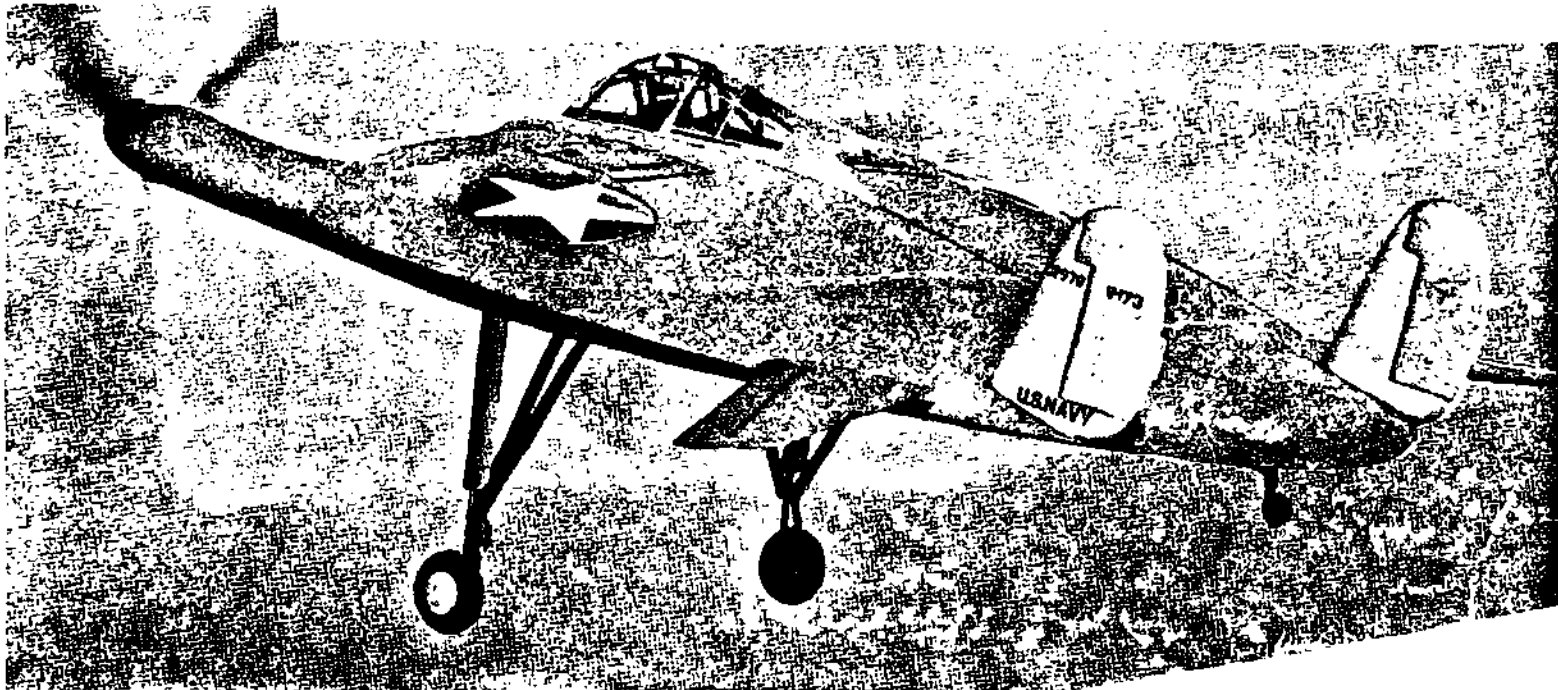

Fig. 8

6. ALTHOUGH APPENDIX "D" is not intended to explain conclusively the phenomenon of "Flying Saucers" the possibility of unconventional type aircraft being the cause of flying disk reports must not be overlooked.

# THE NIGHT SKY

By Walter N. Webb  
MUFON Astronomy Consultant

AUGUST 1985

## Bright Planets (Evening Sky)

Saturn, in Libra, is now low in the SW during twilight, setting about 11:30 PM Daylight Time.

Jupiter, retrograding westward in Capricornus, reaches a point opposite the sun on the 4th, rising in the ESE at sunset and remaining visible all night. This largest of planets now shines at its brightest (magnitude -2.4).

## Bright Planets (Morning Sky):

Our brilliant planet neighbor Venus rises about 2:45 AM in midmonth and is well up in the east before sunrise. Shining at magnitude -3.5, it appears only 2 and 3/4° north of telescopic Halley's Comet on August 1.

Late in the month ruddy Mars reappears dimly very low in the east at dawn.

Jupiter sets in the WSW at sunrise.

## Meteor Shower:

The year's best meteor display, the Perseids, runs from about July 25 to August 18, peaking on the morning of the 12th at a rate of about one meteor per minute toward dawn. A waning crescent moon that morning interferes somewhat. Perseid meteors are swift, yellow, bright, and often leave smokelike trains behind them.

## Halley's Comet:

Now is the time for amateur astronomers with medium-to-large telescopes to begin looking for Comet Halley, the most eagerly awaited astronomical event of this century. Rising in the eastern sky between 2 and 3 AM, the still distant comet will appear telescopically as a tiny dim 13th-magnitude smudge in the upraised club of Orion the Hunter. Avoid the full moonlight by searching around the middle of the month. The comet's position on the 15th is R.A. 6h 01m, Dec. +19° 07' (Epoch 1950) near the star Chi<sup>2</sup> Orionis. Halley will not be visible with the naked eye until December or January.

## Moon Phases:

Last quarter--August 8  
New moon--August 16  
First quarter--August 23  
Full moon--August 30



## The Stars:

August evenings bring the Summer Triangle high overhead. Just to the west of the bright stellar trio lie the faint sprawling constellations of Hercules the Kneeling Giant (look for the so-called Keystone, a small wedge-shaped box) and Ophiuchus the Serpent Bearer shaped like an Arab's tent.

## DIRECTOR'S MESSAGE

By Walt Andrus

**Robert Guenette Productions** in Los Angeles, California, received a contract from H.B.O. (Home Box Office) to produce a current UFO documentary for their national cable television service. MUFON has been working with Mr. **Fred Rosen**, the producer, for several months planning this important film contribution. The majority of the field interview filming was done during the week of May 28 through June 2nd, starting in Albuquerque, N. Mex., followed by Houston, Tex., New Orleans, La., New York, and finishing in Boston, Mass.

In this brief and timely announcement, no attempt will be made to review the many significant UFO cases that were filmed or the names of the numerous people who contributed their time and resources to make this documentary not only entertaining, but an educational film of professional caliber for the fifteen million viewers who subscribe to this service.

\* \* \*

Mr. Rosen has advised that H.B.O. plans to show their new film, tentatively titled "UFOs: What's Going On," during the month of August 1985, so watch your published HBO schedule for showing times in your area. Since MUFON members played a major part in this production, we want to thank each and everyone of you for your cooperation and enthusiasm. This film has the potential of being one of the most significant UFO documentaries produced to date.

My Director's Message has been confined to this one important announcement, due to space limitations, in order to publish the majority of Air Intelligence Report No. 100-203-79 titled "Analysis of Flying Objects Incidents in the U.S.," dated 10 December 1948.

**MUFON**

103 OLDTOWNE RD.  
SEGUIN, TX 78155

# MUFON UFO JOURNAL

NUMBER 208

AUGUST 1985

Founded 1967

OFFICIAL PUBLICATION OF



MUTUAL UFO NETWORK, INC.

\$1.50

## MUFON 1985 UFO Symposium Proceedings

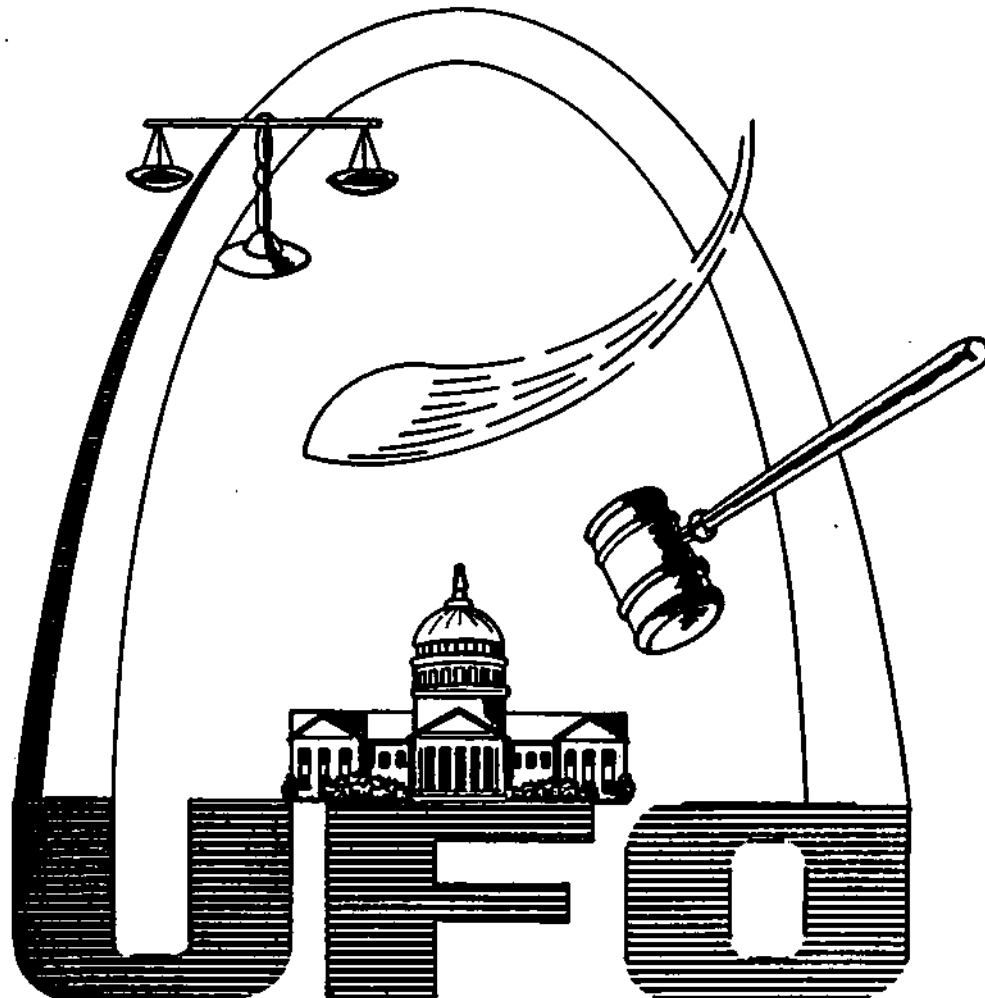

### The Burden of Proof

Saint Louis, Missouri

June 28, 29 & 30

## MUFON UFO JOURNAL

(USPS 002-970)

(ISSN 0270-6822)

103 Oldtowne Rd.

Seguin, Texas 78155-4099

**DENNIS W. STACY**  
Editor

**WALTER H. ANDRUS, JR.**  
International Director and  
Associate Editor

**THOMAS P. DEULEY**  
Art Director

**MILDRED BIESELE**  
Contributing Editor

**ANN DRUFFEL**  
Contributing Editor

**TED BLOECHER**  
**DAVE WEBB**  
Co-Chairmen,  
Humanoid Study Group

**PAUL CERNY**  
Promotion/Publicity

**MARGE CHRISTENSEN**  
Public Relations

**REV. BARRY DOWNING**  
Religion and UFOs

**LUCIUS FARISH**  
Books/Periodicals/History

**ROSETTA HOLMES**  
Promotion/Publicity

**GREG LONG**  
Staff Writer

**SIMONE MENDEZ**  
Staff Artist

**TED PHILLIPS**  
Landing Trace Cases

**JOHN F. SCHUESSLER**  
Medical Cases

**LEONARD STRINGFIELD**  
UFO Crash/Retrieval

**WALTER N. WEBB**  
Astronomy

**NORMA E. SHORT**  
**DWIGHT CONNELLY**

**DENNIS HAUCK**

**RICHARD H. HALL**

**ROBERT V. PRATT**

Editor/Publishers Emeritus

The MUFON UFO JOURNAL is published by the Mutual UFO Network, Inc., Seguin, Texas. Membership/Subscription rates: \$15.00 per year in the U.S.A.; \$16.00 foreign in U.S. funds. Copyright 1985 by the Mutual UFO Network. Second class postage paid at Seguin, Texas. POSTMASTER: Send form 3579 to advise change of address to The MUFON UFO JOURNAL, 103 Oldtowne Rd., Seguin, Texas 78155.

# FROM THE EDITOR

The next best thing to having been there? This issue of the Journal, with its complete print and picture coverage of the 1985 St. Louis Symposium. In addition, there's a preview of the activities planned for the first national UFO Information Week, presented by Marge Christensen, and commentary and suggestions by Larry Bryant concerning the present status of UFO secrecy. Also, most of our usual departments, including The Night Sky, In Others' Words, and Director's Message.

Was UFO Week a success? In terms of the first, nationwide concerted effort of its kind, undoubtedly. But the bottom line, as with most PR programs, is one of dollars. Publicity MUFON, CUFOS and the Fund for UFO Research got. For the momentum to be maintained, however, such organizations need to have brought in new subscribers and increased operating funds. Whether that will prove the case remains to be seen. What is clear, even at this early stage, is that we not rest on our laurels and remember that there are another fifty-one weeks in the year. UFOs don't take vacations. Why should we?

## In this issue

BURDEN OF PROOF by Dennis Stacy	4
UFO INFORMATION WEEK by Marge Christensen	9
SYMPOSIUM SNAPSHOTs by Dennis Stacy	10
NEWS'N'NOTES by Walt Andrus	12
SYMPOSIUM VIDEOTAPES by Joseph Palermo	14
UFO SECRECY UPDATE by Larry Bryant	15
LETTERS	16
THE NIGHT SKY by Walter Webb	18
IN OTHERS' WORDS by Lucius Farish	19
DIRECTOR'S MESSAGE by Walt Andrus	20
COVER by Ronald R. Schmitt	

The Mutual UFO Network, Inc. is exempt from Federal Income Tax under Section 501(c)(3) of the Internal Revenue Code. MUFON is a publicly supported organization of the type described in Section 509(a)(2). Donors may deduct contributions from their Federal income tax. In addition, bequests, legacies, devises, transfers, or gifts are deductible for Federal estate and gift tax purposes if they meet the applicable provisions of Sections 2055, 2106, and 2522 of the code.

The contents of the MUFON UFO JOURNAL are determined by the editor, and do not necessarily represent the official position of MUFON. Opinions of contributors are their own, and do not necessarily reflect those of the editor, the staff, or MUFON. Articles may be forwarded directly to MUFON. Responses to published articles may be in a Letter to the Editor (up to about 400 words) or in a short article (up to about 2,000 words). Thereafter, the "50% rule" is applied: the article author may reply but will be allowed half the wordage used in the response; the responder may answer the author but will be allowed half the wordage used in the author's reply, etc. All submissions are subject to editing for style, clarity, and conciseness.

Permission is hereby granted to quote from this issue provided not more than 200 words are quoted from any one article, the author of the article is given credit, and the statement "Copyright 1985 by the Mutual UFO Network, 103 Oldtowne Rd., Seguin, Texas" is included.

# ST. LOUIS SYMPOSIUM



The Welcome Mat is Out!

*-Dennis Stacy*



Breakfast With Speakers

*-Dennis Stacy*

## BURDEN OF PROOF

By Dennis Stacy

The Sixteenth Annual MUFON Symposium, "UFOs: Burden of Proof," opened with the customary reception Friday night, June 28th, in the stately Chase Park Plaza Hotel, near downtown St. Louis, and within eyesight of the landmark "Golden Arch," commemorating the winning of the West. Sponsored by the UFO Study Group of Greater St. Louis, the Symposium featured a stellar line-up of speakers and, for the first time, a complete videotaping of the full program.

Saturday morning, the proceedings got underway with an early welcome by John Schroeder of St. Louis, who served a delightful stint as Master of Ceremonies. MUFON's International Director, Walt Andrus, then greeted the assembled attendees who had come from as far away as Australia. The first Symposium speaker to the podium was Massachusetts MUFON's Marge Christensen, who also serves as our National Director of Public Relations and publishes the monthly newsletter, "P.I.P.E. Line."

### EDUCATION

The abstract of Marge's speech (and the complete text of all the papers can be obtained in the published Proceedings) can be summarized as follows: "Arguments are presented to show that if the American public were well-informed about the UFO subject, the burden of proof would lie not with UFOlogists, but rather with the U.S. Government to explain to the American people why a major world power is 'not interested' in flying objects which exhibit a propulsion system obviously in advance of our own aircraft, and which have exhibited an interest in our own nuclear weapons storage areas, according to our government's own documents."

As most of you are aware by now, the indefatigable Mrs. Christensen is



**WALT ANDRUS**

also the chief mover and main coordinator of the first National UFO Information Week, scheduled for August 18th through the 25th. Marge reviewed many of the public displays and information projects underway by various state MUFON organizations for that period, but since the details can be found in her own article elsewhere in this issue, I will not go into them here. Suffice it to say that all who have contributed their time and energy to this first-of-its-kind project deserve our congratulations and assistance, and none more than its prime originator, Marge Christensen.

### REPETITIONS

George Fawcett of Lincolnton, North Carolina, followed Marge with a talk on "UFO Repetitions: A Challenge to Scientific Investigations." George's thesis was that certain aspects of UFO

sightings have repeated themselves time and again over the past 40 years on a global scale, and that these repetitious factors present a challenge to both science and society. "Any future solution," said Fawcett, "to the growing worldwide UFO enigma will have to deal directly with these UFO repetitions."

George, MUFON State Director for North Carolina, is a tireless investigator of UFOs who has personally looked into over a thousand reports and authored more than a hundred articles about the subject in various newspapers and magazines. He has also managed to amass a considerable body of UFO ephemera, including the numerous clippings and photographs displayed in his accompanying slide show. Like many of us, George is perplexed both by the phenomenon and by the way it is perceived by various segments of

society, including government and science. In 1984, he noted, Dr. J. Allen Hynek addressed a meeting of the American Association for the Advancement of Science with a talk on "The 125 Properties of the UFO Phenomenon," while James Oberg spoke on "The Absence of a UFO Phenomenon." "How," Fawcett asked, "can something that doesn't exist have 125 properties?"

His own talk to the Symposium centered around 25 particular repeating properties of the UFO phenomenon. These included their unique disc and dome-shapes, high-speed maneuverability, the pacing of cars and airplanes, radar-tracking, falls of angel hair, increases in background radiation, physiological and psychological effects on witnesses, electromagnetic effects, physical landing traces, contacts with alleged entities, periodic increases in the number of sightings reported, associated power failures, and so on.

"The unexplained UFO residue is not just a matter of feelings and general impressions as some would have us believe," concluded Fawcett, "but represents a genuine, growing, global problem, yet to be solved. We have learned a great deal from UFO repetitions already, but I also feel there is a great deal more to be learned."

#### FATAL ENCOUNTER

One of the repeated characteristics of the phenomenon, of course, is the recurring stories of crashed saucers and retrieved alien bodies. And one of the more well-known researchers of this specialized category has been, and is, Leonard Stringfield of Cincinnati, Ohio, the author of "Inside Saucer Post, 3-0 Blue," "Situation Red: The UFO Siege," and several monologues on alleged crash/retrievals. The topic of Leonard's talk before this Symposium was "The Fatal Encounter at Ft. Dix-McGuire: A Case Study; Status Report IV."

On September 23, 1980, said Stringfield, he received the first of what would be an interrupted series of communications with one "Jeffrey Morse," who claimed to be a military policeman on patrol at McGuire AFB,

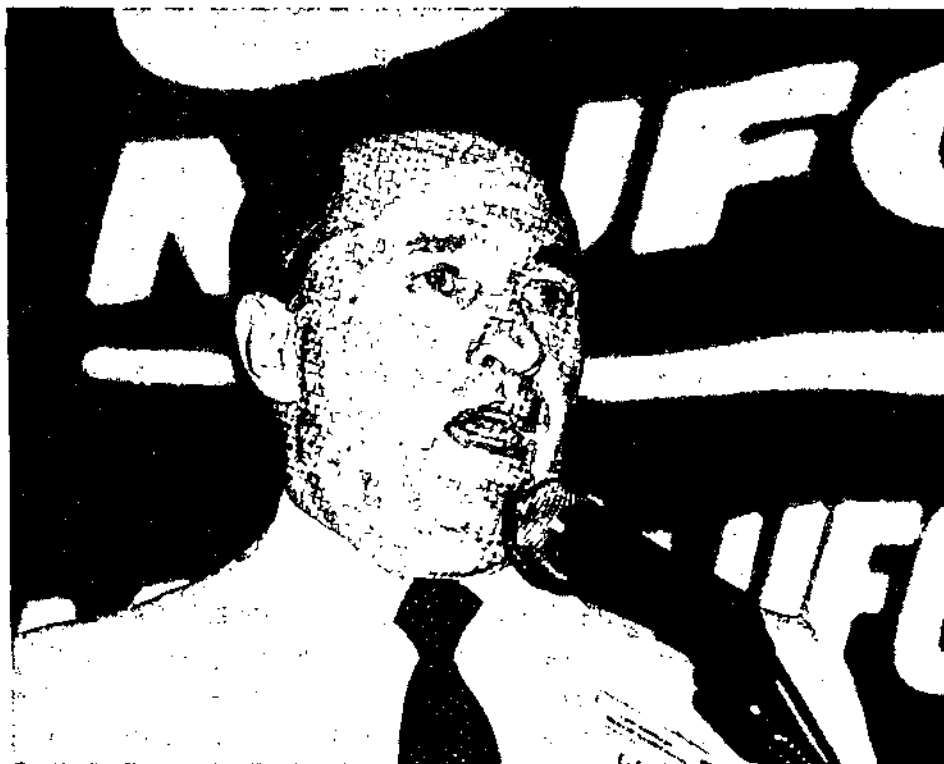

**GEORGE FAWCETT**

New Jersey, adjoining Fort Dix, the night of January 18, 1978. As relayed by Morse, there was considerable UFO activity in the area that night, he alone having seen up to 12 individual, greenish-blue lights flying in various stages of formation. Reportedly, one of these lights came near the car of a Fort Dix MP who was engaged in active pursuit, interfering with the officer's radio transmission.

At that time, according to Morse, a four-foot tall "thing" with grayish-brown skin and fat head appeared in front of his car. The officer fired five times at the thing with a .45, and once overhead at the object hovering in the sky, which then rose straight up and away, joining with 11 other objects. The humanoid ran across the ground and disappeared into some woods, apparently climbing a fence around McGuire and collapsing on the end of an old runway. The area was then cordoned off by MPs, including Morse, who were not themselves allowed any closer. A special group of "blue berets" then arrived on the scene and were placed in charge of the fallen body Morse said he could see no more than 50 feet away. The body was sprayed with something, placed on a platform, and then a

wooden crate built around it in place. It was then put in a metal container and forklifted aboard an air force C-141 bound for Wright-Patterson.

A couple of days afterwards, Morse and other MPs on duty that night were sent to W-P and interrogated about what they had seen and how much they might know. Morse said he signed a document swearing secrecy about the event. After his first contact with Stringfield, he said he had reason to believe his mail was being intercepted, his telephone tapped, and perhaps even personal surveillance maintained.

Stringfield has since continued investigating the case, constrained by Morse's situation (at one time his civilian job appeared threatened) and the usual disappointments of trying to obtain various documents and reports through the Freedom of Information Act. The air force replied that after a five-year waiting period, MP reports are routinely destroyed, the one in question having been scheduled for destruction in January of 1984. Through Morse Stringfield obtained a copy of an "Incident/Complaint Report," form

*(continued next page)*



**PETER GERSTEN**

### **SYMPOSIUM, Continued**

1569, which mentioned "that an unidentified body had been shot," but without official confirmation of same by the air force, the report remains in limbo, somewhere between evidence of a stupendous encounter or a clever hoax.

### **LEGAL PROOF**

New York attorney and chief counsel for CAUS (Citizens Against UFO Secrecy) Peter Gersten, as he did at the M.I.T. MUFON Symposium, addressed the issue of the burden of UFO proof from the viewpoint of a practicing criminal lawyer. "There is already enough evidence in the form of thousands of reports, hundreds of still and moving pictures, and countless government documents to adduce the existence of UFOs," Gersten argued. "The case has already been proved.

But not in court. In September, in Houston, Gersten will carry the \$20 million personal injury suit of the Cash-Landrum case into U.S. District Court, but admits the chances of his winning are "slim and none."

### **MEDICAL EVIDENCE**

investigator. Said medical effects range from anorexia, cancer, hair and fingernail loss to diarrhea, vomiting and other serious disabilities.

Schuessler then offered his own prescription for how future cases involving human injury should be handled and investigated. The first thing is to approach the problem with a positive attitude, and not waste time and energy in negatives. The investigator should have a warm personal regard for the victim, and work closely with competent medical consultants. All relevant information should be collected and detailed records of meetings and interviews kept; photographs should be taken.

"Strive for co-operation with responsible individuals and groups," Schuessler advised, "but do not hesitate to ignore anyone that does not demonstrate ethical behavior. Do not bow to pressure to do anything other than find the truth. Re-visit the case from time to time. Don't just get the report and then forget about the well-being of the victim. Most victims will need some support for months and even years after the event. This is a big responsibility to be shouldered by any investigator. Finally, share the results of your work, so other victims may



**JOHN SCHUESSLER**

benefit.”

## PHYSICAL TRACES

Another excellently illustrated slide show was presented by Ted Phillips on the subject of “Physical Trace Landing Reports: The Case For UFOs.” Phillips, of Reed Springs, Missouri, is also a member of CUFOS and CAUS, and over the years has put together a landing case catalog of some 2,677 reports from 64 countries. “I feel such cases represent one of the most direct approaches to resolving the UFO mystery,” Phillips said. “Traces remain as visible evidence long after the reported event. And if UFOs are not available for study in the laboratory, their physical traces certainly are.”

Phillips then summarized five cases which he admitted were “not well known, not taken from the latest reports, and are perhaps even among the more controversial. They were chosen because they push us to the edge of what we can or should believe.”

Space hardly permits a review of the cases here, but interested parties are strongly urged to consult Phillips’ paper in the published Proceedings, or the video-taping of same. Details of how these can be ordered will be found elsewhere in this issue of the Journal.

## CRASHED SAUCERS

After an evening dinner break, the always engaging William Moore of Burbank, California, regaled the assembled audience with a talk based on two full-length papers in the Proceedings, “Crashed Saucers: Evidence in Search of Proof,” and “The Roswell Incident.” Combined, they cover 50 of 180 published pages, and are well worth the price of admission alone.

Moore contrasted a legendary (and apparently fictitious) crashed saucer report which appeared in Frank Scully’s “Behind the Flying Saucers” with a similar report coming out of Roswell, New Mexico, which he and Stanton Friedman have investigated extensively. Briefly, the former tale can be traced to the handiwork of a convicted con man known as Silas M. Newton, and his equally shady cohort,

the “mysterious Dr. Gee,” who turned out to be, Moore is convinced, one Leo A. GeBauer. Apparently the idea grew out of Newton’s oil leases, GeBauer’s self-taught electrical knowledge, and an aborted Hollywood publicity campaign for a grade-B science-fiction movie known simply as “The Flying Saucer,” which was touted as having real footage of a captured flying saucer.

GeBauer had developed a dubious device known as a “doodlebug,” which was supposed to detect fluctuations in the earth’s magnetic field and thereby signal the presence of oil, gas and other mineral deposits. Newton’s somewhat imbalanced genius derived the idea of heralding the doodlebug as captured saucer technology. Scully, Moore believed, was an unwitting dupe in the scheme. More importantly, Moore

added, the incident reveals how an official FBI document relating to the alleged crashed landing, after a diligent investigation, can be traced back to its fraudulent source in Newton’s active imagination. In contrast, the Roswell Incident continues to hold up under scrutiny, according to Moore and Friedman.

## NOISY NEGATIVISTS

Friedman added a few more details to the Roswell roster in his keynote speech, “Flying Saucers, Noisy Negativists and Truth,” a liberal broadside at Carl Sagan, Philip Klass and other vocal skeptics who, Friedman charged, often resort to outright

(continued next page)



**TED PHILLIPS**



**STANTON T. FRIEDMAN**

### **Symposium, Continued**

distortion of the available evidence. Those who have never had the pleasure of hearing Stanton in person should treat themselves and others to the videotape of his talk. The complete text, of course, can be found in the printed Proceedings.

Following Friedman's presentation, all the speakers were called to the front table to form a panel and respond to questions moderated by MC John Schroeder from the floor.

Sunday morning attendees could sign up for a "Breakfast With the Speakers," which involved a full breakfast buffet and seating with the speaker of your choice, another innovative twist, among several, grafted on the standard Symposium fare by the Greater St. Louis host group, and for

which they are to be recommended. Only one speaker failed to make the morning call. Following breakfast, the annual corporate meeting was held as reported elsewhere.

### **HYPNOSIS**

The afternoon session opened with David Webb's "The Influence of Hypnosis in the Investigation of Abduction Cases." Webb, a senior scientist specializing in solar physics, selected a large sampling of abduction cases to test the hypothesis that hypnosis itself is somehow fundamental to the UFO abduction phenomenon. What he discovered might surprise some. "In forty per cent of the abduction reports in my sample," said Webb, "I found the use of hypnosis was not important in gaining information

about the alleged 'on-board' portion of the experience. In one-third of the reports, hypnosis was not used at all during the investigation." Webb concluded: "Investigators of abduction reports know that the core experience has consistent, recurring elements irrespective of how the information is retrieved. Such cases may represent the key to the UFO mystery. Significant advances in our understanding will occur only when we greatly increase the number of reports investigated and more effectively pool our analytical resources in their analysis. The solution may be within our grasp."

### **ABDUCTION EVIDENCE**

Abduction reports themselves were the subject of New York artist Budd Hopkins' speech. Hopkins is the author of "Missing Time," and is presently working on another book, "The Haunting of Kitley Woods - An Ongoing UFO Saga," which he previewed at last year's MUFON Symposium in San Antonio.

"The subject of UFO abduction reports," Hopkins said, "is approached as if these kidnappings were crimes, and I were an investigator trying to assemble sufficient evidence for a 'grand jury' to decide that such events did, in fact, happen as the abductees claim.

"First, an attempt is made to refute the two theories that claim no kidnappings occurred — that the witnesses are either lying or are somehow deluded. Next, the various classes of evidence are presented to support the physical reality of these kidnappings. These are 1), secondary witnesses to the abductions; 2), physical traces - landing marks on the ground, wounds and marks upon the abductees' bodies; and 3), the congruity of description by the abductees.

"Finally a motive for the 'crime' is presented: a longterm research project upon, and active interaction (including genetic or reproductive experimentation) with human beings by their kidnappers, whom I identify finally as extraterrestrial in origin. And then the

*(continued on page 17)*

# UFO INFORMATION WEEK

By  
**MARGE CHRISTENSEN**

The first national UFO Information Week in the nation's history will be held during the week of August 18-25, 1985. The Mutual UFO Network will sponsor this important endeavor, in cooperation with the Center for UFO Studies and the Fund for UFO Research, in order to heighten public awareness of the UFO subject and of the need for services for research of it. Forty-one MUFON State organizations will participate in this week.

## INITIAL FORUM

Massachusetts will initiate the week's activities with its 1 and ½ day UFO Forum on August 17-18. The Forum will be moderated by Dr. David M. Jacobs, and will feature the following speakers: Dr. J. Allen Hynek, Mr. John Schuessler, Mr. Dan Wright, Dr. Willy Smith, Mr. Budd Hopkins, Mr. Barry Greenwood, and Mrs. Marge Christensen.

UFO exhibits at shopping malls or County Fairs will be held in Texas, Florida, Iowa, Wyoming, Massachusetts, Southern California, Northern California, North Carolina, New Mexico, Pennsylvania, New Jersey and Nebraska.

MUFON organizations in Utah, Wyoming, and Virginia will present photographic exhibits at public libraries.

Iowa will sponsor UFO displays at the Center of Science & Technology and at the Des Moines Park & Recreation Festival.

In Wisconsin, the MUFON organization will present a TV news report on the UFO subject from Milwaukee. Nebraska's MUFON group will launch a new series of 26 half-hour programs on cable television entitled, "Exploring Unexplained Phenomena."

In Washington, the Puget Sound Aerial Phenomena Research Organization will initiate a 24-hour



**MARGE CHRISTENSEN**

*-Dennis Stacy*

UFO Information Service International  
(Tel: 206-721-5035).

Maine, Iowa, Michigan and New Jersey will provide lectures on college campuses, at libraries, and at civic organizations.

## OPINION POLLS

Public opinion polls on the UFO subject will be sponsored in Texas, Maine, Colorado, Iowa, and Illinois. The North Carolina MUFON organization will sponsor a UFO Information Night at a local theatre. Louisiana, Texas, Florida, Oklahoma, South Carolina, North Carolina, New York, Massachusetts, Colorado, Nebraska, Utah, Pennsylvania, New Jersey, Connecticut, Michigan, Missouri, Washington, Northern California, Southern California, Illinois, Georgia, and Wisconsin will sponsor

guest appearances on radio and television.

Press releases to the media will be sent out by Tennessee, New Mexico, Massachusetts, Connecticut, New York, New Jersey, Florida, Texas, South Carolina, North Carolina, Colorado, Illinois, Nebraska, Michigan, Iowa, Northern California, Maine, Washington, Wyoming, Vermont, Missouri, Utah, New Hampshire, Maryland, Washington, D.C., Georgia and Wisconsin.

In New Jersey, a permanent store window display on UFOs will be established. Also, Melanie Benson, wife of State Director Tom Benson, will take a ride in a hot air balloon with a banner advertising the first National UFO Information Week.

MUFON information pages are

*(continued on page 16)*

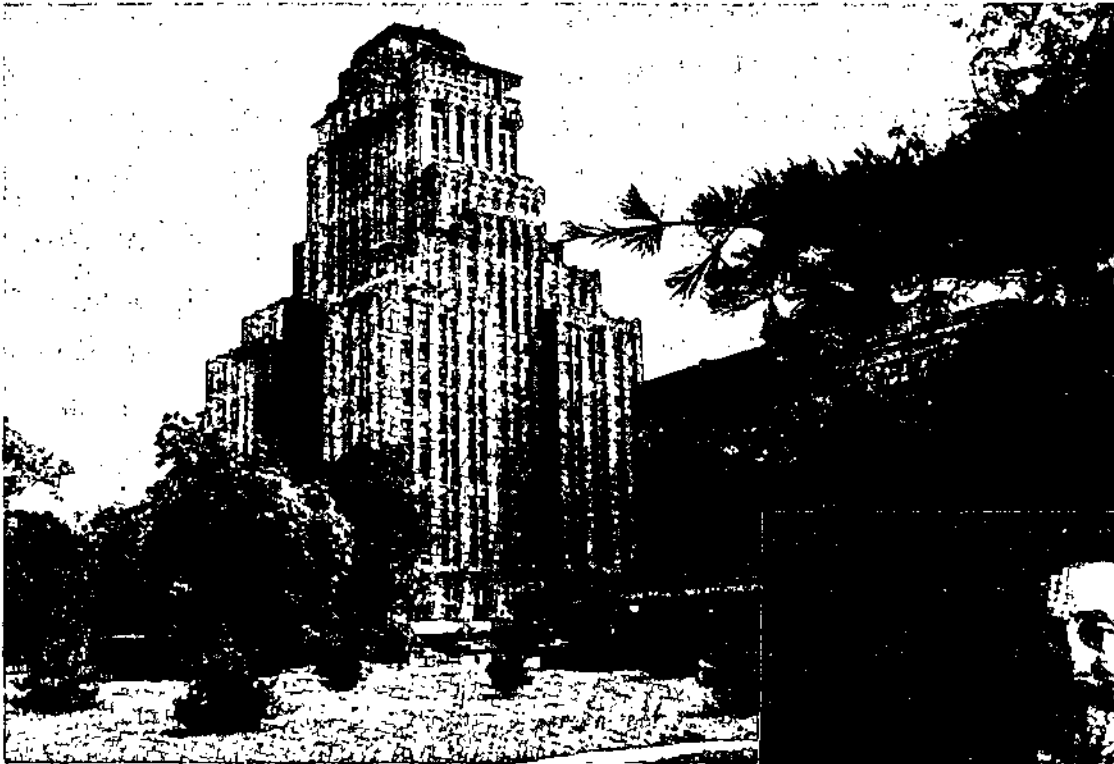

**Chase Park Plaza Hotel**

**John Roppoli With Symposium T-Shirts**



**Display Area**





**Frank Brown's  
UFO Plates**



**Michael Swords  
Between Sessions**



**Master of Ceremonies  
John Schroeder**

*(All photographs by Dennis Stacy)*

## NEWS'N'NOTES

By Walt Andrus

The Annual MUFON Corporate meeting was held Sunday, June 30, 1985 at the Chase Hotel in St. Louis, Missouri in conjunction with the Sixteenth Annual UFO Symposium. The meeting was called to order at 10:30 a.m. by Walter H. Andrus Jr., International Director with John F. Schuessler, Deputy Director for Administration, acting as Secretary.

### CENTRAL DIRECTOR

The UFO Study Group of Greater St. Louis was commended for their well organized and implemented part in hosting the Symposium. The first order of business was to elect a new Central Regional Director to replace Charles L. Tucker whose term had expired on the Board of Directors. Since only one nomination was received, a mail ballot was not required this year. Dan L. Wright, state director from Michigan, was approved and elected by the members present from the twenty central states.

The 1986 MUFON Symposium will be held at Michigan State University in East Lansing on June 27, 28 & 29, 1986 and will be science-oriented (further details in Director's Message).

### FRENCH REPORT

It was announced that Dr. Hynek, Dr. Vallee and Dr. Niemtow had recently flown to France to evaluate the work of GEPAN and to make recommendations upon future funding for UFO investigations and research by the French Government. They also met privately with Claude Poyer former Chief of GEPAN (see separate article in this issue concerning their visit as related by Richard Niemtow, M.D. upon his return).

Ron Lakis was introduced, with credit given for his UFO documentary "The UFO Experience" (see Director's Message for details on how to purchase

the film and the conditions for its use). The film "UFOs: What's Going On?", being produced and directed by Fred Rosen for H.B.O. Cable TV distribution was announced with a tentative release date of August 1985.

Regional and State Directors made their annual reports. Typed copies were submitted in full to the International Director. Brief statements were made by each of the annual meeting audience. Oral reports were made by Paul Cerny (State Director for Northern California and Western Regional Director), Henry H. McKay (Ontario Provincial Director and Candian Regional Director), Joe Santangelo (Eastern Regional Director and MUFON Amateur Radio Net), Dan Wright (State Director for Michigan and Central Regional Director), Forrest Lundberg (Iowa), Leonard Sturm (Illinois), Marge Christensen (Massachusetts), Mildred Biesle (Utah), Steve Toth (Ohio), Ken McLean (Wyoming), Jean Waller (Oklahoma), Michael Brein (Hawaii), Donald Ware (Florida), Donald Schmitt (Wisconsin), Doug Labat (Louisiana), Bruce A. Widaman (Missouri), and Paul Norman (Victoria, Australia).

### FIELD EXAM

Thomas H. Nicholl, Deputy Director for Business Management, was introduced as well as the Assistant State Directors attending the corporate meeting. Dan Wright presented the final version of the Field Investigator's Exam for acceptance by the organization, which was subsequently approved. The exam will be first given to all State Directors, State Section Directors and Field Investigators during the next six months so that all will be familiar with and cognizant of the contents. The program will be administered initially by Mrs. Shirley Coyne in Michigan under the direction of Dan Wright and financed by

MUFON. After all of the above people have taken the examination, a decision will be made as to its application for advancement from Field Investigator Trainee to Field Investigator and who will administer the program in the future. This is a major step in upgrading the professionalism of MUFON investigators and researchers.

A commendation was given to Dan Wright and his committee for developing two 35mm slide sets of 50 and 100 sets for use as visual aids in giving UFO lectures. Only a limited supply is available so please place your orders with Dan Wright, 1502 Marquette, Lansing, MI 48906. The 50 slide set costs \$25.00 and the 100 slide set \$45.00. Marge Christensen reviewed the National UFO Information Week activities throughout the country scheduled for August 18-25, 1985. Both she and Doug Labat discussed the UFO Library Resource Centers in various parts of the country, which is being spearheaded by David Christensen.

### RADIO

Joe Santangelo gave a six month report on the MUFON Amateur Radio Net in which 23 different stations had checked in on Saturday mornings. Due to the "Breakfast with the Speakers," concluding at 10:30 a.m. and the afternoon session starting at 12:30 p.m., it was necessary to adjourn the annual meeting at 12:30 p.m., thereby preventing sufficient time for additional new business on the agenda.

### GEPAN

The French Government is the only nation publicly funding UFO research at the present time through its space program Centre National D'Etudes Spatiales. Group D'Etudes

(continued next page)

## NEWS'N'NOTES, Continued

Phenomenes Aérospatiaux Non Identifiés (GEPAN) is the organization specifically responsible for UFO investigations and research in France. Claude Poher served as Chief of GEPAN for two years, followed by Dr. Alain Esterle, while Jean Jacques Velasco presently occupies this position of responsibility.

### OUTSIDE ADVICE

In order to evaluate future funding for GEPAN, the Prime Minister of France sought the advice of sources independent of political and scientific personnel in France who might be prejudiced. Dr. J. Allen Hynek and Richard C. Niemtzw, M.D. were invited to meet with government officials and to make recommendations for the continuation of GEPAN. Dr. Jacques Vallee accompanied Dr. Hynek and Niemtzw as an unofficial observer to the meetings and conferences due to his interest and knowledge.

The triumvirate arrived in Paris on June 23rd and had lunch with Claude Poher. Mr. Poher is still very interested in UFOs. In spite of rumors circulated a few years ago, he is "alive and well." Poher advised that he will continue to be watching the progress of GEPAN from the sidelines as it faces political attacks.

On Monday, June 24th a conference was held at the French National Space Center in Paris (Centre National D'Etudes Spatiales), attended by 20 to 30 space center officials and university professors. Both Dr. Hynek and Niemtzw presented papers to this prestigious conclave. Dr. Niemtzw's paper was titled "Physiological and radiation effects from intense luminous unidentified flying objects" and Dr. Hynek's was "An approach to the study of unidentified aerospace phenomenon." Hynek discussed his computerized UFO catalog and firmly advised that he supported the activity and efforts of GEPAN and recommended that it not be closed down. Hynek and Niemtzw offered the cooperation of UFO organizations in the U.S.A. to GEPAN and

encouraged international collaboration on exceptional UFO cases in either country. If a significant case occurred in France, Dr. Hynek and Niemtzw would be invited to participate and likewise GEPAN personnel would come to the United States. Unofficially, Jacques Vallee was present as an observer to offer his support to GEPAN and recommend its continuance.

Dr. Niemtzw, who speaks French fluently having attended medical school in France, had two private conversations with top officials of the French space program. Mr. Lions, Director of the National Space Center, felt that GEPAN should continue to be active in spite of political and scientific problems. Mr. J. Gruau, Inspector General of the Space Center and Secretary to the GEPAN Scientific Council also supported the research work of GEPAN.

### SPACE CENTER

The National Space Center Headquarters and offices of GEPAN in Toulouse, France was the site for the meetings on June 25th. Mr. P. Bescond, Under Director of the Space Center at Toulouse welcomed the U.S. Consultants to the seminar/ symposium-style all-day meeting. Dr. Jacques Vallee presented a paper titled "Applications of methods of artificial intelligence for the screening of witness reports." This is a method of determining by telephone, using computer displayed questions, whether a case should be investigated further. All three Consultants recommended that GEPAN should continue in the future due to the wide collection of material that would otherwise be wasted.

They also met Dr. Alain Esterle former Chief of GEPAN who is now involved in evaluation of space programs. Dr. Esterle obtained his Ph.D. from the University of Washington and while Chief of GEPAN, he met with MUFON officers in Houston, Texas.

### FILE ACCESS

On Wednesday, June 26th, Hynek and Niemtzw had the pleasure of

personal access to the GEPAN UFO file and computerized file. They found no evidence of humanoids or UFO crashes or any type of aggressive sightings such as radar or aircraft. All cases were very well investigated. They expressed their desire to continue working with GEPAN and Jean Jacques Velasco, the Chief. In the Paris meeting on June 24, a representative of the Prime Minister was in the audience to observe and report back to his superior.

### NO PRESS

For the record, Richard C. Niemtzw, M.D. was invited as a private citizen and a Consultant to the GEPAN meetings by the French Government. In reality, Dr. Niemtzw is a Major in the U.S.A.F. Medical Corp stationed at Andrews AFB, Maryland. He has a Ph.D. in Biological Sciences. Richard has been a MUFON Consultant in Radiation since 1977, and is presently the State Section Director for Prince Georges County in Maryland. The U.S.A.F. approved of Dr. Niemtzw's visit to France, but he was forbidden to participate in any press conference due to the sensitive nature of his position. We are indebted to Dr. Niemtzw for providing this information to the MUFON UFO JOURNAL by telephone.

The Mutual UFO Network has been cooperating with GEPAN since its inception and will continue to do so. In our library, we have all of their technical reports form No. 3 dated April 1981 through No. 18 dated March 15, 1983 and Note D'Information numbers 2, 3, and 4.

### INDIANA

Jerry L. Sievers, Assistant State Director for Indiana, hosted an excellent UFO meeting in Vincennes, Indiana, at the beautiful Executive Inn on Saturday, July 6th. Following a delicious buffet dinner in the immense dining room, attendees convened in a hotel meeting room where TV equipment had been installed. The purpose of the session was another step in organizing the MUFON team in

(continued on page 18)

## SYMPOSIUM VIDEOTAPES

By  
**JOSEPH L. PALERMO**

At this time, the act of reaching the public with information about ufology seems to be a paramount concern for MUFON. I am proud to say I've finally been able to take steps forward in this department with the video-taping of the entire 1985 MUFON Symposium.

By publication, the production group engaged for not-for-profit Midwest Motion Picture Proteges, Inc., will have post-produced and will be making available, the lectures, atmosphere and excitement of the Symposium on either VHS or Beta tapes. The sale of the Symposium tapes are in two categories....individual lectures at the current cost of \$27.00 or the entire Symposium (roughly 14 hours!) at the current cost of \$121.00. At the time of this writing, we've already received one order for the entire Symposium and are expecting more in the mail.

The individual lectures are as follows....Peter Gersten's **THE BURDEN OF PROOF**, William Moore's **CRASHED SAUCERS**, Stanton T. Friedman's **NOISY NEGATIVISTS**, George Fawcett's **UFO REPETITIONS**, Ted Phillips' **PHYSICAL TRACE LANDING REPORTS**, John Schuessler's **MEDICAL EVIDENCE**, Budd Hopkins' **ABDUCTION REPORTS**, David Webb's **HYPNOSIS AND ABDUCTION CASES**, and Leonard Stringfield's **FATALENCOUNTER AT FT. DIX**.

An equally exciting opportunity for all of us is that Midwest Films Productions, Inc., the company aiding MMPPI in its releasing efforts, is in negotiations with video clubs in the St. Louis area for working the tapes in a rental fashion for us!

I've been a member of MUFON now for two years and have heard of and seen the need for both money and public education. I'm working on both.

If you would like to order either an individual lecture, several individual



Lights, Camera, Action!

*-Dennis Stacy*

lectures, or the complete Symposium set, simply write down what you want....specify VHS or Beta, make your check or money order payable to Midwest Motion Picture Proteges, Inc., and mail to MMPPI, 9327 Corregidor, St. Louis, Missouri 63134. Our phone number is (314) 423-2827 with an answer machine for placing orders also. If you call, be sure and leave your number and an appropriate time you may be reached. (DUE TO THE COMPLETENESS OF EVENT COVERAGE AND THE FACT THAT YOUR CHECK MAY BE FROM OUT OF TOWN/STATE, PLEASE ALLOW 4 TO 6 WEEKS FOR CHECK CLEARANCE, DUBBING, AND DELIVERY.) Also, if you would like to rent the tapes, take this article to your video club and ask them to contact us.

We'll be happy to arrange a deal with them.

These tapes will not only bring you up-to-date, they are capable of informing those family members and friends who you wish you could explain ufology to, plus they will also raise monies for both MUFON and MMPPI.

**MUFON**  
**AMATEUR RADIO NET**  
**EVERY SATURDAY MORNING**  
**AT 0600 EST (OR DST)**  
**ON 7237 KHZ SSB**

# UFO SECRECY UPDATE

By Larry Bryant

What could (and should) have been a publicity bombshell at the MUFON St. Louis Symposium this June turned out to be a misfire.

Whether the case study in question — Leonard H. Stringfield's status update on the Fort Dix-McGuire AFB, N.J., UFO encounter/alien-body retrieval operation of January 18, 1978 — should thus be written off by the casual observer as a *passee* myth or as an expose slightly ahead of its time, I know not. What I do know, though, ought to serve as a new point of departure for dealing with the Dix-McGuire incident.

*Item:* After months of exhaustive research by Stringfield, Richard Hall, and a few others, this case seems to be standing the test of time. Indeed, Hall puts it at the top of the credibility scale as regards Stringfield's assortment of UFO crash-retrieval accounts.

*Item:* The uniqueness of the case lies in two mutually supporting pieces of evidence: (1) the testimony of one of its principals, a former McGuire security policeman, who feels it necessary not to "go public" with his name until he's assured of a safe forum for his story (such as a Congressional committee hearing?); (2) a "leaked" document confirming the basic facts of his story — the document being an "Incident Report" filed by McGuire Security Police and forwarded to the USAF Office of Special Investigations (O.S.O.) for coordination of any follow-up reports.

## DATA QUEST

It's those follow-up reports that can help resolve any question about the case's authenticity, comparative importance, and outcome. Where do the reports repose now? What agencies have had custody over them during the past seven years, and why? How can we get Congress to launch an inquiry into the events and documentation

surrounding the incident?

Finding the answers will of course require additional time and effort on the part of us all, the only reward being Truth.

Where to start? Writing to your representatives and senators in Congress might help. In your letter, enclose a copy of the Incident Report (reproduced on pages 60-61 in the St. Louis MUFON Symposium Proceedings) and ask the Congress member to send it to the appropriate House/Senate committee for their review and investigation. About 30 days after your member thus responds to this request, write direct to the committee chairman to determine what his committee is doing, or plans to do, to resolve the issue. His answer ought to prove useful in preparing a letter-to-the-editor or Op-ED Page item for your local newspaper. (Once the news media begin to sink their teeth into this case, the snowball should start rolling on its own.)

While you thus perform your civic duty on the stage of public opinion, you should know that back in the wings Richard Hall and others are trying to track down the current location of the several principals cited in the preliminary Incident Report (whose names are deleted from the published copy of the report so as to protect them from the same kind of reprisal allegedly incurred by Stringfield's informant).

## NEW CAMPAIGN

Aside from the approach to Congress, we have another, high-visibility avenue to the Truth: the U.S. Freedom of Information Act.

Accordingly, a group of researchers in the Washington, D.C., area has embarked on the FOIA pursuit of all records pertaining to the O.S.I. involvement in the incident's reportage and aftermath: such records as the autopsy report on the "one body of

unknown origin" (the terminology entered on the DD Form 1569 Incident Report), the intelligence-analysis report on the body's personal effects, the various witness statements, and the audio/video/polygraph transcripts of all interrogation sessions with the incident's participants and witnesses.

In the coming months of expected USAF stonewalling on the group's pursuit, they'll be mapping out the long-term strategy. This will entail the services of an attorney for filing the appropriate lawsuit, the preparation of interrogatories for the court to grant a "discovery motion" toward determining the exact nature and whereabouts of the sought-for records, and any necessary issuing of the subpoenas to both participants in and witnesses to the incident, in an effort to show that an event of this magnitude must have generated a permanently maintained file of records.

Of course, such an undertaking will incur substantial expense. But it also offers you a chance to put your UFO-research contributions toward a history-making pay-off. Here's the proposal: send whatever you can, right now, to the Fund for UFO Research, Inc. (P.O. Box 277, Mount Rainier, MD 20712). On the tax-deductible check/money order, note your desire that the donation be applied to the "Dix-McGuire FOIA UFO Litigation Project." The monies thus received will be kept separate from the Fund's other resources, expressly to wage this battle for the release of *all* official information on New Jersey's ultimate UFO encounter. Note: any left-over project funds will be transferred to the Fund's general operating account.

As the suite moves forward in the courts, check the pages of the *MUFON UFO Journal* for periodic status reports. Remember: the success of this project depends on your personal

(continued on page 16)

## LETTERS

By the Readers

**Dear Editor,**

The recent article (June 1985) by Philip Mantle reminds us that if we should happen to observe or confront any ET technology, we would judge it to be possessed of magical powers. It is worth emphasizing that, as a corollary, what they could do should violate or circumvent many of our present laws of physics, probably much more than what we can do now would violate the laws of nature as understood by scientists of 500 years ago. In short, their technology should seem beyond the range of ordinary knowledge, or occult, according to the dictionary meaning. As Mantle infers, this should include the high technology that would permit easy travel between star systems.

A related point coming up frequently now in recent scientific literature on this topic is that our galaxy should be "saturated" with ET races, due to their past colonization and migration, if not due also to their independent earlier starts of life on millions of suitable planets. The fact that scientists have not spotted any official evidence of them is now taken to mean that they have a sort of embargo or quarantine against us, until we reach a level of understanding where we could accept their presence without launching nuclear warheads or going into panic or feeling that our religious values are threatened. From this it follows that such ETs, for the most part, must be benevolent in a hands-off way, especially since we otherwise would not exist apparently unexploited by them today.

The embargo idea, described for example in *The Planetary Report* (Vol. V, No. 1, 1985, p.20), further implies that they are observing us, if only to determine when it will be time for the embargo to be lifted. However, any abrupt lifting of the embargo would probably have disastrous results at present. Perhaps UFOs are one way in

which we are being prepared gradually to accept the nearby presence of diverse ET civilizations far superior to ours, but being prepared in a manner designed not to alert scientists and governments, so that the "official" embargo can hold for a while longer. If so, it is possible that they may have contacted a few individuals in a similar manner, so as not to catch the attention of scientists, in order to explain more fully what may be going on, and to get their messages into our literature.

Putting all of this together, the E. Meier case seems to be a good candidate for one such definitive contact. This is the case briefly described in the book reviewed favorably by L. Farish (July-Aug., 1984). Although the case had previously been mostly dismissed partly because Meier's huge numbers of color photos of posing saucer craft look too good, it is mainly because the very lengthy, ET message accompanying his contact sessions seems occult in many respects. From the foregoing discussion, however, this is more a point in favor than against, provided the accompanying physical evidence is very firm. I know of none of his several hundred UFO photos that have been found fraudulent. Claims to the contrary by Ground Saucer Watch around 1980 seem unsupported by the evidence, and seem forced by the opinions of its director who, in *Flying Saucer Review* (Vol. 30, No. 5, 1985) wrote, "Simply stated, the few bona fide 'saucers' actually observed during the last forty years represent clandestine government technology testing, which we can support with technical reports and photos."

It should also be pointed out that no hoaxist has been uncovered, after the ten years since the Meier affair began, and the names of at least 28 witnesses to secondary events in the case are known.

**James W. Deardorff, Ph.D.**

**Dear Editor,**

In the May 1985 issue of the Journal, I made a sarcastic joke at Robert Sheaffer's expense. I wish to apologize to Mr. Sheaffer and to all who seek to make this subject respectable.

Young ufologists, take heed of my error: Moral character is not earned at the expense of another. Please remember Dr. Hynek's maxim: Ridicule is not a part of the scientific method and people should not be taught that it is!

**Daniel Eden**

---

### SECRECACY, Continued

commitment toward its related activities (e.g., in mobilizing Congressional action), as well as on whatever financial support you can marshal.

---

### UFO WEEK, Continued

being furnished to all states by Walt Andrus. Public service announcements for radio will be provided by John Timmerman, of the Center for UFO Studies. Posters stressing public awareness of this week are being designed by Wisconsin State Director, Donald Schmidt, and these will be furnished to all MUFON State Organizations.

Slide sets and videotape documentaries are being made available to all State organizations by MUFON's P.I.P.E. Committee.

According to Dr. Bruce Maccabee, the Fund for UFO Research in Washington, D.C. will donate sets of U.S. Government documents released under the Freedom of Information Act, to Washington, D.C. area public libraries.

And finally, MUFON Coordinator for Africa, Cynthia Hind, has announced that Africa will observe a

*(continued next page)*

## UFO WEEK, Continued

UFO Information Week which will coincide with our own. Cynthia will hold a one-day UFO Forum, make radio and T.V. appearances, and coordinate other activities that week.

Increased public awareness of the UFO subject and increased public support for recognition of the subject as a legitimate area for serious, scientific research, could conceivably move us closer to a solution to this vital enigma. Likewise, the solution to the UFO enigma could very well launch mankind into new discoveries of technology, medicine, communications, and an infinite amount of other areas. All of this could result in a quantum leap forward for the human race.

Please do your part to support National UFO Information Week.

## SYMPOSIUM, Continued

prosecution will rest its case."

Hopkins also conducted an impromptu afternoon workshop on how to investigate UFO incidents in general, and clues that might indicate an abduction had taken place in particular. These latter often include a disjointed, or chopped-up, account of events that might indicate a period of missing time.

All in all, the Symposium was a resounding success, due both to the speakers, and their well-illustrated presentations, and the foresight and warm hospitality of the host Greater St. Louis MUFON group. For the first time, the entire proceedings were videotaped, attendees had an opportunity to breakfast with their favorite speakers, and T-shirts and

bookbags emblazoned with the MUFON logo were offered for sale. St. Louis definitely set precedents that will hopefully be emulated by subsequent symposia. Congratulations are due all around.



BUDD HOPKINS

### **BREAKFAST WITH THE SPEAKERS**

**16th ANNUAL  
MUFON SYMPOSIUM**

**CHASE HOTEL**

**St. Louis, Mo. 63108  
SUNDAY, JUNE 30, 1985**

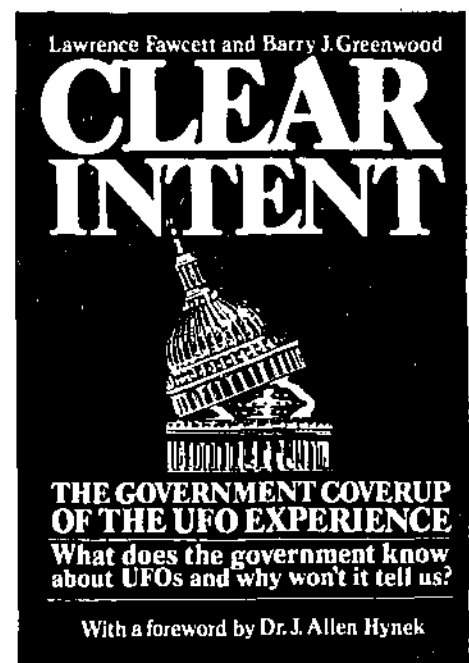

# THE NIGHT SKY

By Walter N. Webb  
MUFON Astronomy Consultant

SEPTEMBER 1985

## Bright Planets (Evening Sky):

The two giant planets of the solar system can be seen at the same time during twilight. Jupiter, still retrograding westward in Capricornus, glows brilliantly in the SE while fainter Saturn in Libra shines in the SW. The latter sets about 9:30 PM Daylight Time in midmonth. Jupiter is due south at 10 PM.

## Bright Planets (Morning Sky):

The brightest planet Venus rises north of east about 3:45 AM in midmonth, followed by the much dimmer red planet Mars an hour later in the same direction. Venus appears 5° south of the crescent moon on the 12th; the planet and the star Regulus make a close pair on the 21st.

Jupiter sets in the WSW at about 2:30 AM in midmonth. It is 4° north of the gibbous moon at 2 AM on the 24th.

## Halley's Comet:

"The Comet" is now within range of backyard astronomers with 6-to-8-inch telescopes. In midnorthern latitudes the dim object rises about 12:30 AM Daylight Time in midmonth north of east between the stars 68 and 71 Orionis (exact position on the 15th is R.A. 6h 13m, Dec. +19° 37' [1950 coordinates]). Best viewing period is from about Sept. 10 to 25 when moonlight won't be a factor. During this time-frame the comet's magnitude increases from 12.2 to 11.4.

## Moon Phases:

Last quarter--Sept. 7  
New moon--Sept. 14  
First quarter--Sept. 21  
Full moon--Sept. 28 (Harvest Moon)

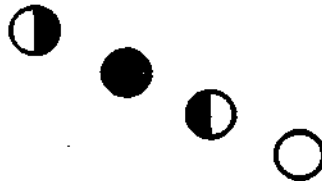

## The Stars:

At 10 PM in mid-September the sky is evenly split between the summer stars in the western half and the autumn constellations in the eastern half. The fall season's celestial symbol, the Great Square of Pegasus, is easily visible in the east while the summer symbol, the Summer Triangle, stands high in the west.

Three bright stars near the horizon create frequent false UFO reports at this time of the year. Watch out for yellow-white Capella in the NE, red Antares in the WSW, and orange Arcturus in the WNW. Atmospheric refraction causes such low stars to change colors and to appear to move about.

The Milky Way now passes directly overhead from NE to SW, its best evening appearance of the year.

## NEWS'N'NOTES, Continued

Indiana. Participants attended from Indianapolis to the north and south to the Ohio River, virtually half of the state.

State Section Directors present were Kerry Dean Teverbaugh (Vigo and Clay Counties), Francis L. Ridge (Posey, Vanderburgh and Gibson Counties), James C. DeLotel (Clark, Floyd and Harrison Counties), and Jerry L. Sievers (Knox, Daviess and Sullivan Counties). Kerry Dean Teverbaugh, meteorologist for WTWO-TV in Terre Haute, served as master of ceremonies. Mr. Sievers handled the business meeting in which he discussed the proposed newsletter for Indiana MUFON, organizational plans, and National UFO Information Week.

Michael B. White, State Section Director for Monroe and Brown Counties, has produced a short, professionally-done UFO documentary for Channel 4 WTTV in Bloomington, depicting sightings at an area known as Lucky Point (south of Monroe City along the White River), including interviews with witnesses and investigators. In a two-part article in *The Saturday Evening Post* magazine (March 1984), Donald W. White related some of these incidents in his article titled "Flying Saucers: Are They Us?" After the meeting was adjourned Saturday evening, four carloads of people drove to Lucky Point for a short skywatch.

Walt Andrus gave a short presentation on the objectives of the Mutual UFO Network, the MUFON UFO JOURNAL, the MUFON Field Investigator's Manual and displayed the current MUFON 1985 UFO Symposium Proceedings, specifically for those attending who were not familiar with MUFON. News media present, in addition to one of the local radio stations, included reporters from the *Indianapolis News* and the *Terre Haute Gazette*.

Debbie, the principal in Budd Hopkins 1984 Symposium paper titled "The Haunting of Kitley Woods," shared some of her personal

(continued on page 19)

# IN OTHERS' WORDS

By  
Lucius Farish

The **NATIONAL ENQUIRER's** issue of May 21 reported on Dr. David Jacobs' college course on the UFO subject, taught at Temple University in Philadelphia. Dr. Jacobs comments on the increasing number of UFO abduction reports, saying the abductees' stories are believable for a number of reasons. An article in the **ENQUIRER's** May 28 issue quotes Brad Steiger and Hayden Hewes as saying that Bigfoot creatures are lower-life forms which have been brought here by UFO occupants from other planets. The pilot of an Iberia Airlines jetliner says he was ordered to change course to investigate a brilliant UFO seen over the Canary Islands, according to a report in the July 2 issue of **ENQUIRER**.

Those who have read Zecharia Sitchin's two previous books, **THE 12TH PLANET** and **THE STAIRWAY TO HEAVEN**, will certainly want to obtain his newest title, **THE WARS OF GODS AND MEN**. In the previous books, Sitchin cited ancient Sumerian and Biblical references to support his theory that the human race was "created" by extraterrestrials. In **THE WARS OF GODS AND MEN**, he continues his central theme, amplifying his previous conclusions with new evidence from his research. There is a 15-page listing of references in this book, so one can see that Sitchin has done his homework before setting out his controversial theories. I personally regard all three books as "must" reading and look forward to many more volumes in the "Earth Chronicles" series of books. Copies of the three books may be obtained from Avon Books (1790 Broadway - New York, NY 10019) in paperback editions. **THE 12TH PLANET** is \$4.50; the two later books are \$3.95 each.

Richard Michael Rasmussen's **THE UFO LITERATURE** is the latest annotated bibliography of English-language books dealing with the UFO

subject. Rasmussen includes chapters on "The Nature of the Literature" and "UFOs in Literature: A Brief History." While not a complete listing of all published works (as is the case with all such bibliographies, it seems), this compilation does include some titles which are little-known. Overall, however, one can question the need for yet another reference work of this sort. Another drawback is the price (\$29.95) for a 263-page hardcover, even though it is nicely done.

If you want to add **THE UFO LITERATURE** to your UFO literature, the publisher is McFarland & Company, Inc. - Box 611 - Jefferson, NC 28640.

## MESSAGE, Continued

In the March 1985 issue of the **Journal**, a new magazine titled **THE UNKNOWN** was announced with Jon Violette and Stan Mussman as Co-Editors. The original investors in this project have decided not to continue because of a lack of commitment from advertisers. This has necessitated a reorganization, as well as exploring some alternative approaches to marketing. However, it does not look like **THE UNKNOWN** will debut on the newsstands this year according to Jon Violette.

Ron Lakis, Producer of the KPIX-TV UFO documentary, "The UFO Experience" has purchased the syndication rights for this film, and is making copies available for purchase by individuals for personal use. The film may not be aired on TV stations unless the station enters into an agreement with Mr. Lakis in regard to payment of royalties. Lakis hopes to sell 250 copies of the film in order to fund the cost of a second documentary on the UFO subject. Tapes may be purchased for \$39.95 plus shipping from: **STARRION PRODUCTIONS, P.O. Box 31-555, San Francisco, CA 94131.** The film is highly recommended to all interested people due to its professional caliber and because it features many MUFON people.

\* \* \*

Dr. Ramon De Aguilar has announced that they will be sponsoring a meeting in the Republic of Panama on

September 19-22, 1985, titled "Primer Congreso Latinoamericano y del Caribe." Anyone interested in attending should write to Dr. Aguilar at Apartado 681, Panama 9A, Republic of Panama.

\* \* \*

A report on the MUFON Annual Corporate Meeting held in St. Louis appears elsewhere in this issue.

## NEWS'N'NOTES, Continued

experiences and answered questions from the audience. She has become an enthusiastic member and promotes MUFON in the Indianapolis area. Several other attendees told of their personal UFO sightings and were filmed by Terry Dean. Michael White has filmed Debbie on several occasions for a possible future documentary. Debbie participated with Walt Andrus on the one hour WLS-TV program "AM Chicago" on January 18, 1985.

Mr. Sievers is to be commended for arranging this informative meeting as a means of organizing UFO investigative teams in the "Hoosier State." We heartily recommend this idea to every state, because it becomes an ongoing "National UFO Information Week."

## NEWS FLASH

### "UFO — WHAT'S GOING ON?"

**H.B.O. Programmed for September  
DATES & TIMES (CDST) FOR SHOWING:**

Sept. 10	9:00 PM
Sept. 18	10:50 PM
Sept. 21	5:00 PM
Sept. 23	10:15 PM
Sept. 26	9:00 PM
Sept. 29	9:15 PM

Please refer to your local cable guide for local programing times.

# MUFON

103 OLDTOWNE RD.  
SEGUIN, TX 78155

# DIRECTOR'S MESSAGE

by  
Walt Andrus

\* \* \*

The August Journal is a special issue devoted to the very enjoyable and educational MUFON 1985 UFO Symposium at the Chase Hotel in St. Louis, Missouri. Congratulations are extended to **Cliff Palmberg**, Chairman, and his outstanding host committee for a superb meeting. The elegant Chase Hotel provided ideal facilities for the sixteenth annual MUFON symposium. Since MUFON was founded in the St. Louis/Quincy, Illinois locale in 1969, a large number of the founding members were present to reminisce and to visit their friends in Ufology.

**Dan Wright** led a twelve-member Michigan MUFON contingent to St. Louis to specifically invite everyone to attend the MUFON 1986 UFO Symposium to be held at the Kellogg Center for Continuing Education, Michigan State University in East Lansing on June 27, 28 and 29, 1986. His host committee provided literature to entice visitors to the Symposium under the state banner "Say Yes to Michigan." Speakers already confirmed are **Dr. J. Allen Hynek**, **Dr. Bruce S. Maccabee**, **Dr. David M. Jacobs**, **Dr. Michael Swords** and **Mrs. Marge Christensen**.

\* \* \*

The MUFON Annual UFO Symposium is intended to examine the scientific dilemma known as unidentified flying objects. By increased awareness, the public is served. In recognition of the University's mission to inform and educate, MUFON'S 17th Annual UFO Symposium is sponsored by the Division of Lifelong Education Programs. Michigan State University takes no position regarding the subject of aerial phenomena. Fees for all Symposium sessions, workshops, wine-cheese reception, and related activities are \$25.00 in advance. Now is the time to plan next year's summer vacation to visit the beautiful state of Michigan.

MUFON's success may be directly attributed to the leadership at the state level where UFO investigative teams are organized. **David E. Rubien** of Saunderston, R.I., a former State Section Director has accepted the responsibility of State Director for Rhode Island. A graduate of the University of Rhode Island, Mr. Rubien is now a developer.

**Richard D. Seifried**, State Director for Ohio has made the following new promotions: **Christine A. Hanson**, Dayton, Ohio, from Field Investigator Trainee to State Section Director for Montgomery, Preble and Greene Counties; and **Jennie** (Mrs. Gordon) **Zeidman**, Columbus, Ohio to State Section Director for Franklin and Delaware Counties. **Irena Scott**, Ph.D., who resides in Galena, Ohio, recently volunteered to become a Consultant in Physiology and a Field Investigator. Dr. Scott will also be working with Jennie Zeidman in Delaware County. Dr. Scott is employed as a Researcher at Battelle Memorial Institute and is a Research Associate at the Ohio State University Medical School, both in Columbus.

**Dan Wright** has selected **Wayne Erickson** of Redford, Mich., to be the State Section Director for Wayne and Oakland Counties. Mr. Erickson has a B.S.E.E. degree and is amateur radio operator W8ZDX. **Marge Christensen**, State Director for Massachusetts, has appointed **Victor W. Zeller**, M.A.T. in Physics, to become a Research Specialist. Mr. Zeller, who resides in South Dartmouth, Mass., is a College Professor who teaches physics and astronomy.

**Doug Labat**, State Director for Louisiana, promoted **Richard S. Matthews** to State Section Director for the Louisiana Parishes of Orleans, St. Bernard, Jefferson, St. Charles and Plaquemines in the New Orleans area. Mr. Matthews has become a real asset to Mr. Labat in helping to organize the

State of Louisiana.

\* \* \*

**Robert Guenette Productions** in Los Angeles, was contracted by Home Box Office (H.B.O.) to produce a UFO documentary to be shown to their 15 million cable subscribers. For several months, your Director has been working with **Fred Rosen**, the producer/director, as a Consultant. The film has been tentatively titled "UFOs: What's Going on." Fred Rosen was targeting for an August showing, however the listing does not appear in the August cable programming for H.B.O. Watch your TV cable guide for a possible showing in September, because this is a more realistic schedule.

\* \* \*

**Michael D. Hart**, Director of The Compufon Network, P.O. Box 954, Duvall, Washington 98019 and the Pudget Sound Aerial Phenomena Research have donated an Atari 1200XL (64K) computer to the Mutual UFO Network. The Compufon Network has placed their new IBM PC in operation and is entering their newsletter on a "bulletin board" service. They may be contacted by calling (206) 788-5901. Mr. Hart is on the MUFON Staff for Computer Science. MUFON members constitute 26% of the Compufon membership, leading all organizations. The MUFON headquarters is seeking a modem that is compatible with the Atari System, such as an MPP-1000C or a Hayes Smartmodem.

\* \* \*

Video tapes were made of the entire MUFON 1985 UFO Symposium in St. Louis by **Joe Palermo** of Midwest Motion Picture Proteges, Inc. and are available for purchase. Please refer to a separate article in this issue of the Journal for details.

\* \* \*

(continued on page 19)

# MUFON UFO JOURNAL

NUMBER 209

SEPTEMBER 1985

Founded 1967

OFFICIAL PUBLICATION OF



MUTUAL UFO NETWORK, INC.

\$1.50

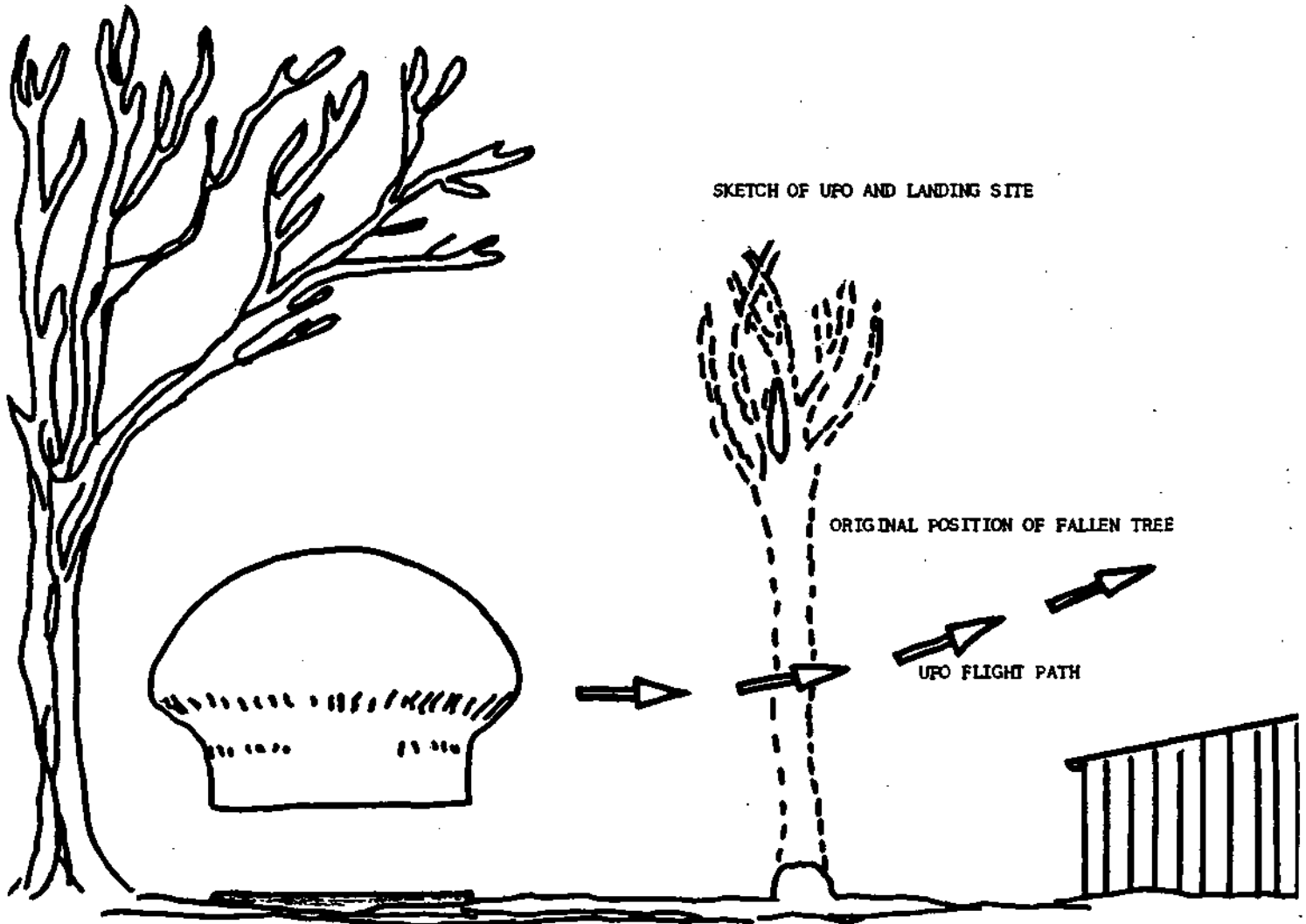

## DELPHOS, KANSAS

**MUFON UFO JOURNAL**  
 (USPS 002-970)  
 (ISSN 0270-6822)  
 103 Oldtowne Rd.  
 Seguin, Texas 78155-4099

**DENNIS W. STACY**  
 Editor

**WALTER H. ANDRUS, JR.**  
 International Director and  
 Associate Editor

**THOMAS P. DEULEY**  
 Art Director

**MILDRED BIESELE**  
 Contributing Editor

**ANN DRUFFEL**  
 Contributing Editor

**TED BLOECHER**  
**DAVE WEBB**

Co-Chairmen,  
 Humanoid Study Group

**PAUL CERNY**  
 Promotion/Publicity

**MARGE CHRISTENSEN**  
 Public Relations

**REV. BARRY DOWNING**  
 Religion and UFOs

**LUCIUS FARISH**  
 Books/Periodicals/History

**ROSETTA HOLMES**  
 Promotion/Publicity

**GREG LONG**  
 Staff Writer

**JAMES LEMING**  
**SIMONE MENDEZ**  
 Staff Artists

**TED PHILLIPS**  
 Landing Trace Cases

**JOHN F. SCHUESSLER**  
 Medical Cases

**LEONARD STRINGFIELD**  
 UFO Crash/Retrieval

**WALTER N. WEBB**  
 Astronomy

**NORMA E. SHORT**  
**DWIGHT CONNELLY**

**DENNIS HAUCK**  
**RICHARD H. HALL**  
**ROBERT V. PRATT**

Editor/Publishers Emeritus

The MUFON UFO JOURNAL is published by the Mutual UFO Network, Inc., Seguin, Texas. Membership/Subscription rates: \$15.00 per year in the U.S.A.; \$16.00 foreign in U.S. funds. Copyright 1985 by the Mutual UFO Network. Second class postage paid at Seguin, Texas. POSTMASTER: Send form 3579 to advise change of address to The MUFON UFO JOURNAL, 103 Oldtowne Rd., Seguin, Texas 78155.

# FROM THE EDITOR

Herein, Ted Phillips' original report on the Delphos, Kansas, physical trace landing case, prior to an update of subsequent investigations; Jim Oberg's "snipe hunt" for electrophonic signals from space; Dan Wright's trenchant criticisms of UFO field investigations, and remedy for same; an exchange of letters between England's Randles and Ridpath on Rendlesham; and my own synopsis of Bill Moore's St. Louis Symposium speech, in addition, of course, to our regular features.

In the future look forward to articles on the lifting power of UFOs, a survey and pictures of National UFO Information Week activities, and a catch-up collection of recent sightings.

## In this issue

DOODLEBUGS & LITTLE GREEN MEN, by Dennis Stacy .....	3
INVESTIGATOR'S JIGSAW by Dan Wright .....	4
SNIPE HUNT IN SPACE by James Oberg .....	5
DELPHOS, KANSAS, CASE by Ted Phillips .....	8
LETTERS by Readers .....	15
THE NIGHT SKY by Walter Webb .....	18
DIRECTOR'S MESSAGE by Walt Andrus .....	20

The Mutual UFO Network, Inc. is exempt from Federal Income Tax under Section 501(c)(3) of the Internal Revenue Code. MUFON is a publicly supported organization of the type described in Section 509(a)(2). Donors may deduct contributions from their Federal income tax. In addition, bequests, legacies, devises, transfers, or gifts are deductible for Federal estate and gift tax purposes if they meet the applicable provisions of Sections 2055, 2106, and 2522 of the code.

The contents of the MUFON UFO JOURNAL are determined by the editor, and do not necessarily represent the official position of MUFON. Opinions of contributors are their own, and do not necessarily reflect those of the editor, the staff, or MUFON. Articles may be forwarded directly to MUFON. Responses to published articles may be in a Letter to the Editor (up to about 400 words) or in a short article (up to about 2,000 words). Thereafter, the "50% rule" is applied: the article author may reply but will be allowed half the wordage used in the response; the responder may answer the author but will be allowed half the wordage used in the author's reply, etc. All submissions are subject to editing for style, clarity, and conciseness.

Permission is hereby granted to quote from this issue provided not more than 200 words are quoted from any one article, the author of the article is given credit, and the statement "Copyright 1985 by the Mutual UFO Network, 103 Oldtowne Rd., Seguin, Texas" is included.

# DOODLEBUGS & LITTLE GREEN MEN

By Dennis Stacy

In 1950 the first of the post World War II UFO books, *Behind the Flying Saucers*, appeared in the nation's bookstores and was an immediate success. Surprisingly, or perhaps not so surprisingly considering some of its revelations, the author was well-known Hollywood columnist, Frank X. Scully, whose "Scully's Scrapbook" graced the pages of "Weekly Variety."

Among Scully's more startling pronouncements was the claim that at least four flying saucers had already crashed or landed on our planet, resulting in the retrieval of some 36 bodies, all between 36 and 40 inches high. The first of these was reportedly found outside Aztec, New Mexico, and contained 16 dead bodies. The saucer, 99 feet in diameter and based on a measurement system of nines as opposed to tens, supposedly sustained only a broken porthole in the crash/landing from which its occupants succumbed.

"It made a nice story, except that if you consider Scully's source, I think you'll agree it never happened," author William Moore (*The Roswell Incident*) told the MUFON symposium in St. Louis. Unfortunately, added Moore, it spawned a whole series of similar rumors and stories of crashed saucers in the American southwest that continue to pop up and plague the UFO literature. Invariably, wreckage and alien crew are surreptitiously recovered by military authorities and spirited off to Hangar 18 at Wright-Patterson Field, Dayton, Ohio. Moore should know, as his own book, co-authored with Charles Berlitz, has sometimes been accused of repeating the same tale.

## DR. GEE

Scully's informant was the late Silas M. Newton, a confidence man who could apparently charm the dimples off a golf ball (he was an excellent amateur player) and his



William Moore at St. Louis

— Dennis Stacy

cohort in the charade, a mysterious "Dr. Gee." identified by Moore as one Leo Arnold Julius GeBauer. Newton, who had known Scully since 1944, would later introduce GeBauer as a prominent "magnetic scientist" who had been privileged to examine the crashed saucer. "Today we would call GeBauer an amateur inventor," said Moore. "but he had taught himself electronics at a time when there was little formal training in the field. He was a shrewd operator, too, with a considerable FBI file by the time he and Newton met, but nowhere near as intelligent as Newton." As early as 1938, GeBauer had been investigated for violation of the White Salve Traffic Act. An ardent Nazi sympathizer, he operated under at least eleven aliases.

The madness to Newton's method was designed to bolster a device developed by GeBauer known as the "Doodlebug." GeBauer claimed the

doodlebug could detect fluctuations in the earth's magnetic field which pinpointed oil, gas and other deposits. Allegedly, it could also measure a person's health the same way. By the time he and Newton met in the summer of 1949, GeBauer had become involved with a wealthy Denver industrialist and inventor in his own right, Herman Flader. GeBauer convincingly demonstrated the ability of the doodlebug to determine the depth of several new water wells on Flader's property, and the result was Colorado Geophysics, Inc., a partnership between the two, with Flader putting up the funding for three more doodlebugs and GeBauer supplying the technology. Flader managed to drag a few friends into the scheme; GeBauer managed to spend the money. Newton met GeBauer through Flader and quickly

(continued on page 16)

# INVESTIGATOR'S JIGSAW

By Dan Wright

## THE PUZZLE

To the community of voluntary investigators, the UFO phenomenon is akin to solving a dozen jigsaw puzzles at once, each with thousands of pieces thrown together and whose ultimate shapes and sizes are unknown. Moreover, we are given only one piece at a time to examine.

The most distressing problem, however, is that the great majority of pieces are flawed and must be discarded after examination. Some are wafer thin and fall apart as soon as we touch them, while others have only a small nodule out of place that is not easily detected. Over three decades of attempts to discover the parameters of this multi-various puzzle, an alarming number of flawed pieces that should have been scrapped were included instead, distorting the overall picture and leading us to premature — sometimes disastrous — conclusions that harmed our credibility as puzzle solvers.

It is certainly time that privately funded investigative organizations acted their age. Yet, we continue to err with such regularity that even the most sophisticated computerized cataloguing system cannot eliminate the inclusion of flawed cases — IFOs. Little wonder that scientists have not accepted the proposition in large numbers.

The integrity of individual reports submitted, after all, is dependent on the conclusions of the field investigator. If the case is handled sloppily, or if the investigator is not competent to discern an IFO from a UFO, an exciting encounter is unintentionally fabricated from evidence of a satellite, an advertising plane or the myriad stimuli that routinely fool the public.

## OBJECTIVITY

The bottom line in our

investigative conclusions is objectivity. Far too many of us simply have an attitude problem: To find a meteor in what at first appeared to be an anomalous event is viewed as somehow a failure, a disappointment and waste of time. And so there is a tendency to give the benefit of doubt to factors that don't fit, to ignore any impediments in the witness' account that are counter to our predispositions.

What we don't know about UFOs is obviously considerable, and understandably so. But it is inexcusable when we fail to grasp IFO events.

Some of what we must all be familiar with involves nothing more sophisticated than sitting out on our back lawns on a starry night. Monitoring the various satellites for direction, luminosity and duration affords basic insights. Similarly, the several prominent meteor showers occurring every year offer each of us the opportunity to study characteristics such as peak periods, sound and vapor trails associated with them. Observing large and small aircraft is valuable in terms of their differing configurations of anti-collision and running lights. The failure of most of us to make such observations indicates a fundamental lack of commitment.

Relatedly, it is safe to assume that few investigators are acquainted with the ad plane companies in their state. Many do not renew necessary contacts with state and local police departments, airports and military bases. They have never purchased an investigative handbook or a UFO encyclopedia. In effect, they demonstrate a disinterest in learning the basics of their purported avocation.

If we remain ignorant of radar functioning or the optical properties of cameras and binoculars, if we continue individually without a thorough grounding in past UFO events and principles conveyed by Hynek, Vallee, Fowler and others, we only serve to

muddy the waters.

Through the energy of Hopkins and the psychology professionals with whom he collaborated, we now know a great deal more about abduction sequences. And because of the unselfish commitment of Greenwood, Fawcett, Gersten and Todd, we have documented the true nature of government involvement in the subject. As important as these areas are to UFO research, they have little practical value to the great share of CUFOS and MUFON card holders. Yet, it seems that far too many of us are much more interested in discussing nasal implants or the Bentwaters incident than learning to properly use our own sighting report forms.

The crucial part of any investigation is the witness interview, which is more of an art than a science. Proper interviewing is largely a matter of experience. But an appalling lack of common sense has pervaded the process, thereby distorting thousands of cases and rendering them useless. Indeed, a primary reason for the UNICAT system presently being developed is to eliminate a significant share of cases on file wherein the investigation was conducted shoddily, to find that core of reports which stand the harsh light of scrutiny.

## BIASES

Because of investigator bias and sloppiness, inadequate preparation is made before the interview; improper settings are selected; exaggerated body language by the interviewer elicits hyperbole in the retelling; ineffective listening causes important points to be missed or misconstrued; UFO-related jargon intimates the witness; and, most importantly, leading witnesses with either-or questions and references to the "craft" or the "UFO" affirms a

(continued on page 17)

# SNIPE HUNT IN SPACE

BY JAMES OBERG

Practically every kid who's ever been involved with the outdoors has been involved, just once, with a "snipe hunt." On advice of older and wiser kids, you sit up all night with a sack, calling out "Here, snipe! Here, snipe!", while back at the campfire the older and wiser kids are rolling with laughter.

The analogy occurred to me very early on the morning of April 19, when, with a handful of other volunteer space program employees, I stood far out on the NASA Johnson Space Center (Houston) antenna range preparing to hold an electromagnetic sack and call hopefully into the sky.

We were there to attempt to record very low frequency radio noise from the reentry fireball plasma trail of "Discovery," as shuttle mission 51-DR came to a fiery climax with a fly-by of the Houston area en route to a Florida touchdown.

## RADIO NOISES

Such radio noise, in the half to five kilohertz region (that is, with wavelengths of dozens of miles!), was still hypothetical. It had not even been suspected until, the previous November, more than a dozen Houston area eyewitnesses reported strange "hissing" noises simultaneously accompanying the spectacular pre-dawn overflight of the descending STS 51-A mission.

Such entirely unexpected perceptions brought to mind the old traditions of anomalous "electro-phonetic sound" which, on at least three hundred well documented occasions over the past several centuries, accompanied the perceptions of very bright fireball meteors. While many scientists quickly dismissed such accounts as psychologically induced, others suspected that the super-hot plasma trails might be emitting radio noise which was somehow converted into an aural perception. And in fact,



Lardas, Kenney, Oberg

artificial radio noise at those frequencies was shown to cause the perception of "hissing" among some — but not all — test subjects.

The "hissing" phenomenon associated with shuttle entries seemed to provide a serendipitous key to solving the old mystery. Here was a situation where well-instrumented researchers could lie in wait for the expected, predictable appearance of what had hitherto been an entirely random occurrence.

The research was relevant to the "UFO mystery" in many ways. First, it was a genuine atmospheric electromagnetic phenomenon for which science had no real explanation. Second, the "electro-phonetic sounds" phenomenon rested entirely on anecdotal evidence and a few attempts at laboratory controlled experiments (as mentioned, these radio frequencies DID seem to generate "hisses" in the heads of SOME test subjects). Thirdly, the instrumentation being used was very similar to radio gear long proposed as

"UFO detectors," which were supposed to notice anomalous radio noise. Success in this "shuttle sounds" search should prove helpful to researchers in ufology, least of all as mere encouragement, and possibly also as demonstration of technological feasibility and of possible new electromagnetic radiation generation and propagation mechanics within the atmosphere.

## TEST RUN

So here we were on a crisp spring morning, just after sunrise, with the mission's landing already put off one rev by bad weather, tuning in a receiver, tape unit, and directional loop antenna. If such static existed, it might just show up, although the expected range — about a hundred miles — was so great that discouraged NASA scientists had decided not to even try on this mission. We weren't that smart, so we were out

(continued on page 7)

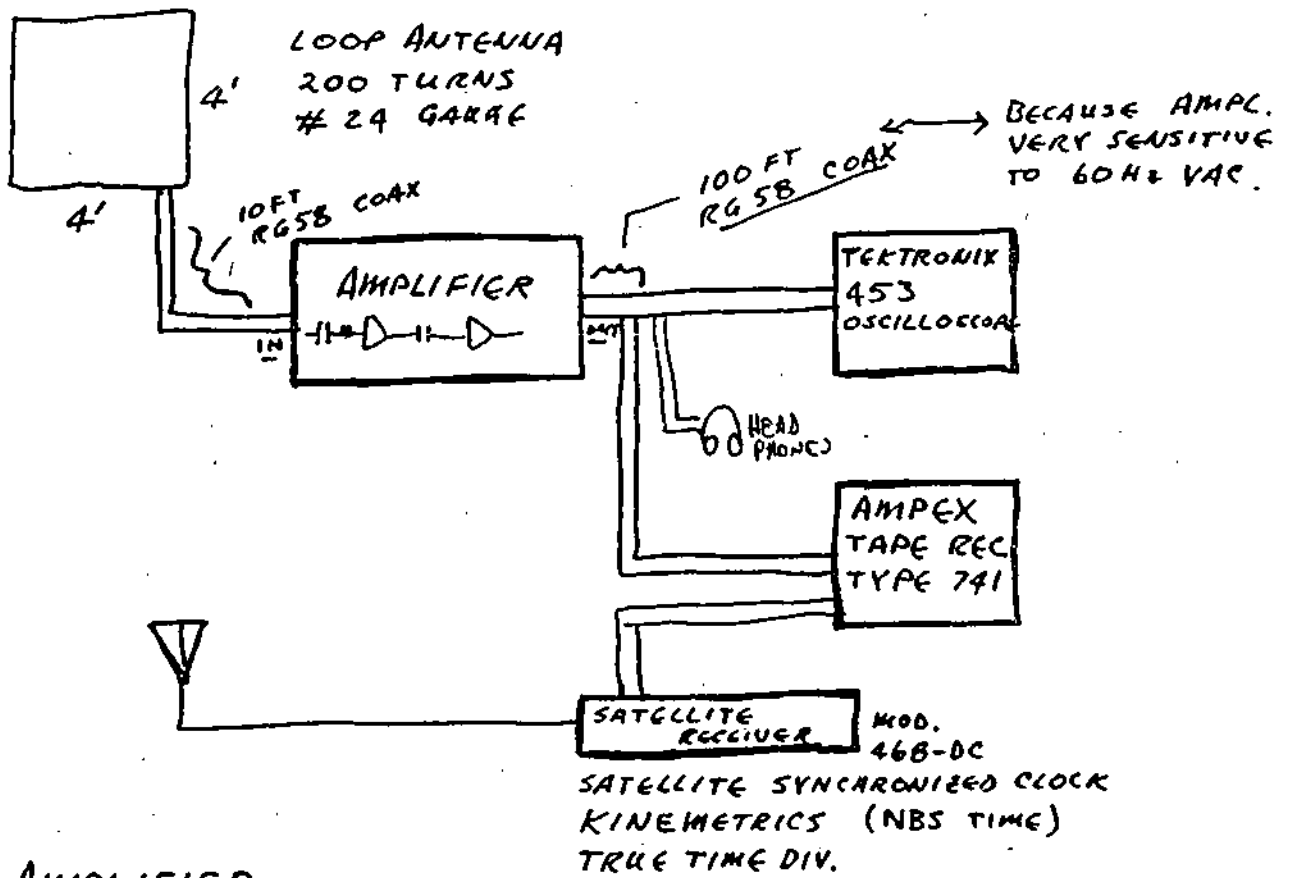

### AMPLIFIER

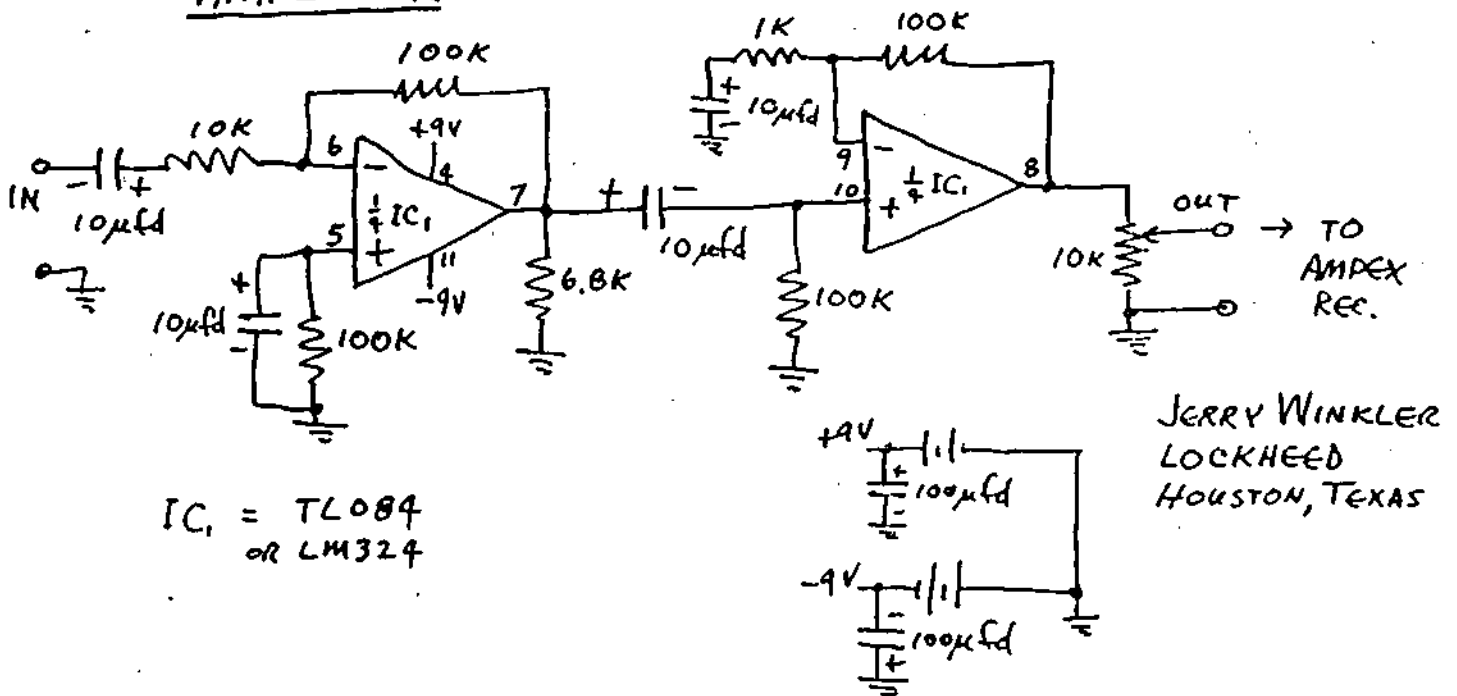

VLF RECEIVING SYSTEM



Loop Antennas

### SNIPE, continued

on the range when the NASA scientists — foolish boys! — were snug in their beds. But since I had been instrumental in instigating and encouraging this whole observation plan, I felt a duty to be there to see what was caught. Half a world away, simultaneously but late in the evening of the same day in Australia, physicist Colin Keay (who

had written several papers on the electrophonic phenomenon and who excitedly joined the “brain trust” when I had sent him a letter describing the November experiences ) sat by his telephone, waiting for news.

With a radio tuned to the Mission Control Center feed, we kept track of the orbiter’s descent. It crossed California, New Mexico, then was in radio contact with a radio site on the Johnson Space Center itself. I scanned the sky with binoculars, seeking for any visual hint of its passing, but saw nothing. Pat Kenney, another space engineer, listened to an earplug hooked to the antenna; our colleague Mark Lardas kept a visual lookout; another engineer watched an oscilloscope for any “signal” above background noise.

At the time of closest approach, with the orbiter doing Mach 6 at 200,000 feet, about a hundred miles due south of us, the background static of sporadic cracklings became a continuous roar. The line on the oscilloscope humped dramatically from the normal quivering flat line. For five seconds this abnormal phenomenon continued, and then the signals fell back to normal.

Were we capturing the electromagnetic snipe? The widetrack tape sucked it all in and stored it safely away. But weeks of analysis with a frequency analyzer, on a space/time-available no-budget basis, still lay ahead. The indications were suggestive, but not overwhelming. Still, we were excited enough to miss hearing the spaceship’s sonic boom — which everybody else outside at JSC seems to have heard, eight minutes after the passage.

### POSITIVE RESULTS

Later we learned that the analysis had indeed been positive. SOMETHING different from background noise had blared briefly through the electromagnetic spectrum. It was too weak and elusive to analyze more precisely, but it was there, and future expeditions will seek to chase it down more aggressively. Keay may even fly up from down under to be on hand.

This particular space shuttle mission had been only the fourth to fly past Houston: 41-B in February 1984 revealed its predawn fire trail to only a lucky few observers far enough south to escape the Houston cloud cover; 51-A in November was close enough and advertised enough to pull out enough pre-dawn witnesses so that many of them sensed the “hiss”; 51-C in January was a DOD mission so its midday flyover followed a classified ground track (many of us still heard the sonic boom).

Future flyovers look less frequent than initially hoped: some missions will be landing at Edwards AFB in California, while others will come in from 57 degree high inclination orbits, with their plasma trails across the Great Lakes. And even normal Florida landing approaches can fly past Houston up to hundreds of miles north or south. Hence it may take up to a year to “capture” more nearby — descent plasma trail radio noise, if — and it is still an if — such a phenomenon is real.

We’ll be out there, hunting for electromagnetic snipe. Open the sack, careful, now! Anything inside? Hissss.....

## MUFON RADIO NET

### DISTRICTS

<u>FIRST</u>	<u>SECOND</u>	<u>THIRD</u>	<u>FOURTH</u>	<u>FIFTH</u>	<u>SIX &amp; SEVEN</u>	<u>EIGHTH</u>	<u>NINE &amp; ZERO</u>
N1JS	WB20GS	WA3QLW	K4HXC	W5UAA	W6LTP/7	KNQN	WAOBN
W1LHV	WA2IUI	K3HWH	WA4NKZ	WA5CTJ		W8ZDX	NOCIS
N1BDC	WA2VBT	W31KG	WA4RPU	K5WLT		KA80GF	WB9QQH
K1AJL	N2EQL	WB3AMR	N4JUB	KA5RRL		KA8RWM	KAOLYY
	N2EPG	N3BBI	W4SKE			WD8PLP	WOAJA
			N4FSZ			K8ZDZ	KAODIG

# DELPHOS, KANSAS, CASE

By Ted Phillips

## INTRODUCTION

In order to set the stage for a series of previously unpublished articles to follow on "Delphos Revisited" by Walt Andrus, the Editors feel that it is imperative that current readers be familiar with Mr. Phillip's original investigations taken from the MUFON file.

A brightly glowing object was observed very close to the ground (CEII) at a farm near Delphos, Kansas on November 2, 1971 at 1900 C.S.T. Delphos is located 11 miles northeast of Minneapolis, in Ottawa County, Kansas. The site of the observation was on the Durel Johnson farm, half a mile north and half a mile east of Delphos. The Johnson farm is located in a flat section of the state composed primarily of cultivated fields and scattered tree lines.

The witnesses were Durel Johnson, aged 52, Erma Johnson, 49, and Ronald "Ronnie" Johnson, 16. Possible confirming witnesses were Elton Smith, School Principal, Delphos, and Lester Ernsberger of Minneapolis. An investigation was conducted at the site on November 3, 1971, by Sheriff Ralph Enlow, Undersheriff Harlan Enlow, and Kansas Highway Patrol Trooper Kenneth Yager. Further investigations were made on December 4, 1971 and January 11, 1972 by Mr. Phillips.

(Color photographs of the scene were made by Frank E. Shrimplin, MUFON State Section Director from Valley Fields, Kansas on November 4, 1971. He was accompanied by William E. Hurtig, a Methodist Minister, now living in Silver Lake, Kansas. Reverend Hurtig lived for 20 years on the farm presently owned by the Johnsons.)

-Walt Andrus

## THE OBSERVATION

At approximately 7:00 p.m.



Ted Phillips

- Dennis Stacy

C.S.T., November 2, 1971, Ronald Johnson was tending the sheep, accompanied by his dog. Mrs. Johnson called from the back door of the Johnson house asking Ronald to come to supper; he replied that he would be through in a short time. After Mr. and Mrs. Johnson had finished their meal, Mrs. Johnson called the boy again, this time he didn't reply. Mrs. Johnson stated that she didn't see anything of an unusual nature, such as a glow and did not hear any sound.

Ronald stated that as he worked in the sheep pen and just after his mother called to him the first time, he heard a rumbling sound and the object was suddenly illuminated. Ronald and the dog did not notice the object prior to the sound. The object was illuminated from top to bottom by multicolored light. The illumination did not come from individual lights but rather it was a mass of varied colors over the entire

surface. An actual metallic surface could not be seen, however, the boy could make out a definite shape. The object appeared to be slightly domed at the top and base with a slight bulge at the center. There was a bright glow between the base and the ground. The object was hovering about 2 feet above the ground, and at no time did the witness see the object touch the ground.

The witness was about 75 feet from the object and had a fairly clear view of it. Upon seeing the object he stood quite still, and noted that the dog was very quiet. Ronald stated that the colors were blue, red and orange and that the colors did not change at any time. The object had an estimated diameter of 9 feet and appeared to be about 10 feet high. He could not see any surface details because of the glow, which was

(continued next page)

## DELPHOS, continued

quite bright as the trees in the area were illuminated, as was the ground. The boy said that it hurt his eyes when he looked directly at the object, and for several days following the incident his eyes were sore, and he suffered from headaches.

The sheep were obviously disturbed by the presence of the object, or by the sound as they were bellowing. Mr. Johnson stated that the sheep would jump from the pen each evening for a week after the incident.

The boy was sure that he would have seen the object before the rumbling sound began had it been illuminated. Ronald likened the sound to that of an old washing machine which vibrates. After several minutes the object brightened at the base. The glow at the base enlarged somewhat and the object began to ascend with considerable speed at an angle, passing over a nearby shed by about 4 feet. As it cleared the shed the sound changed to a high-pitched sound, like that of a jet aircraft. As the sound changed the boy was suddenly unable to see — he claimed to have lost his vision completely. I asked him if he could see spots in his vision, as one would following a photographic flash; he said he could not. (We may assume — and this would be an assumption only — that it was at this time that Mrs. Johnson called the boy the second time. As the object had ascended and was to the south of the house at a point not visible from the back door, Mrs. Johnson would not have heard or seen anything unusual.) Ronald stated that, while unable to see, he could hear the sound fading into the distance.

### REGAINS SIGHT

After what seemed to be several minutes, the boy began to regain his sight. He saw the object in the sky and ran to the house. He told his parents that a flying saucer or something had landed and was still visible in the sky. Mr. and Mrs. Johnson both stated that the boy was frightened and excited when he entered the house. They didn't believe the boy at first and he became very aggravated.

Mr. Johnson then went outside and saw a bright light in the southern sky. He called out and all three observed the light at a point 180° due south. They described the light as being very bright and at least half the apparent diameter of the full moon. I asked if it would have been as bright and large as an automobile light 100 feet away and they said it was larger and brighter. As they observed the light, which was the color of an arcwelder, it was decreasing in size, moving into the distance. They watched the light for a brief time and then proceeded to the landing site. They did not see the object again.

As Mr. and Mrs. Johnson and Ronald walked around the shed adjacent to the site, they saw, in the darkness, a glowing circle. The soil surface was glowing a bright grey-white. Portions of nearby trees reportedly glowed also. Mr. and Mrs. Johnson touched the ring surface, but it was not warm. The texture of the soil surface felt strange, like a slick crust, as if the soil was crystalized. Mrs. Johnson noted an immediate numbing at her finger tips. She rubbed her hand against her leg in an attempt to remove the dirt and that portion of her leg also became numb. She likened the numbness to that of a local anesthetic. Mr. Johnson noted the numbness in his fingers also. For about two weeks this condition prevented Mrs. Johnson from taking pulse readings on patients at the rest home where she works. She stated that she simply could not feel anything with her finger tips. Mr. Johnson said that the numbness left his fingers in a much shorter time. They did not consult a doctor. Mrs. Johnson ran to the house and picked up their polaroid camera, returned to the site, and photographed it. Upon returning to the house, Mr. Johnson called Mr. Willard Critchfield, Editor of the Delphos Republican; according to Mr. Critchfield the time was about 8:00 p.m. No action was taken at that time.

The following day — November 3, 1971 — Mr. Johnson and Ronald drove into Delphos and talked with Mrs. Thaddia Smith. I quote from Mrs. Smith's report given to Sheriff Enlow on the afternoon of November 3, 1971: "While visiting with Mr. Johnson and

Ronnie during the noon hour, Wednesday, November 3, I learned some of the details of the previous night. This is the way it was told to me.

"Ronnie, aged 16, accompanied by his dog was taking care of his flock of sheep at approximately 7:00 p.m. when suddenly he saw a blinding, brilliant light, and heard a loud rumbling sound that turned into a sound similar to a jet engine, and then the light ascended into the heavens in a southerly direction from an area in a shelter belt of trees behind a hog house near the sheep pen.

"He was nearly paralyzed with fear, but finally managed to run to the house and called his parents out of the house to look at the light which was still visible high in the heavens to the south of their house.

"The boy and his dog were still afraid. The dog wandered around the yard with his head up in the air as though still looking for the object.

"The family went to the area where the object was seen ascending from (sic). There they found a large circle on the ground that had a fluorescent glow in the dark. Mrs. Johnson took a picture of the area.

"I, after listening to their experience, a little skeptical, having my curiosity aroused and being a newspaper reporter, decided to go to the Johnson farm home to take a picture of the area where the object had been.

"I was accompanied by my husband, Lester Smith, and son-in-law, Kenneth McCullick, who were also curious.

"Upon arriving at the scene I knew instantly that something had left evidence that it had been there.

"The circle was still very distinct and plain to see. The soil was dried and crusted. The circle or ring was approximately 8 feet across, the center of the ring and outside area were still muddy from recent rains. The area of the ring that was dried was about a foot across and was very light in color.

"The object had crushed a dead tree to the ground either when it landed or took off, and from appearance had broken a limb of a live tree when it landed. The broken limb was most

(continued on page 12)



DELPHOS, KANSAS WITNESS: RONALD JOHNSON AGE 16 AND HIS DOG SNOWBALL SAW A BRIGHTLY GLOWING OBJECT APPROXIMATELY 9 FT. IN DIAMETER AND 10 FT. HIGH, HOVERING ABOUT TWO FEET ABOVE THE GROUND WITHIN 75 FT. OF THE WITNESS.



RONALD JOHNSON AND HIS FATHER DUREL JOHNSON AGE 52 HOLDING GEIGER COUNTER USED BY UNDERSHERIFF HARLEN ENLOW TO MEASURE FOR RADIATION DURING HIS INVESTIGATION.



PHOTO MADE BY TED PHILLIPS, MUFON SPECIALIST IN LANDING TRACE CASES ON DECEMBER 4, 1971. NOTE WATER ON GROUND, BUT SNOW DID NOT MELT IN RING AREA. THE SOIL WOULD NOT ABSORB WATER. DEHYDRATION OF SOIL EXTENDED TO A DEPTH OF 14 INCHES IN RING.



THIS LIMB WAS APPARENTLY TWISTED AND BROKEN DUE TO FORCES ASSOCIATED WITH THE HOVERING OBJECT. NOTE STANDING WATER AT THE BASE OF THIS TREE, SINCE SNOW WAS MELTING.

## DELPHOS, continued

unusual, it would snap and break as though it had been dead for quite some time, yet it was green under the bark, and the upper area still had green leaves clinging to its branches. However the lower area was free of all leaves and some of the bark on the lower areas looked as though it had been blistered and had a whitish cast.

"I took a picture of the area and went back to the newspaper office to write my story. Thinking about the almost unbelievable things I had seen I decided to call the Concordia Weather Bureau to find out if they had seen any unidentifiable objects on radar, and was told their radar had not been turned on and they advised me to notify the Ottawa County Sheriff's Office. I called radio station KSAL in Salina to report the incident. They also advised me to report to the sheriff's office, which I did."

The above report was written by Mrs. Thaddia Smith and given to Ottawa County Sheriff Enlow.

### SECOND REPORT

I now quote from a written report by Undersheriff Harlan Enlow given to me on January 11, 1972:

"Report of Harlan Enlow, Undersheriff, dated November 3, 1971.

"At approx. 1:30 p.m. 11-03-71 this Officer received a call from Thaddia Smith, a reporter for the *Delphos Republican*, advising that a UFO had been reported at 7:00 p.m. 11-02-71 at the Durel Johnson farm 1 mile north and 1/2 mile east of Delphos. Mrs. Smith advised that she had reported the incident to the Weather Bureau at Concordia, Kansas and to KSAL Radio in Salina, Kansas, and that both had advised her to report it to this office.

"At approx. 2:00 p.m. 11-03-71 Sheriff Ralph Enlow, Kansas Highway Patrol Trooper Kenneth Yager, and Undersheriff Harlan Enlow went to the Johnson farm and talked to Mr. and Mrs. Johnson and their son Ronnie who had observed the UFO the previous night.

"We were advised by Ronnie that at approx. 7:00 p.m. 11-02-71 while out in the sheep pen with the sheep he had

heard a loud noise and saw a bright light coming from a shelter belt behind the hog house. As he watched, the light rose into the sky and left in a southerly direction. Ronnie ran into the house and got his parents who came out and saw the object in the sky still headed South.

"Mr. Johnson took us out behind the hog house where we observed a ring shaped somewhat like a donut with a hole in the middle. The ring was completely dry with the hole in the middle and outside of the ring mud. There were limbs broken from a tree and a dead tree broken off, there. There was a slight discoloration on the trees. We were given a picture taken the previous evening by Mrs. Johnson which showed that the ring glowed in the dark. Undersheriff Enlow took a soil sample from the dried ring and photographed it.

"The soil sample taken was almost white in color and very dry. We used a Civil Defense Radiological Monitor to determine that the soil was not radioactive. The soil sample and photographs are stored in the vault in the Sheriff's Office pending further investigation by the proper authorities.

"On 11-03-71 Mr. Lester Ernsbarger of 416 Argyle St. in Minneapolis advised Deputy Sheriff Leonard Simpson that at approx. 7:30 p.m. 11-02-71 he had observed a bright light descending in the sky in the Delphos area.

Signed Harlan Enlow, Undersheriff"

### FIELD INVESTIGATION

On the evening of December 2, 1971, I received a telephone call from Dr. J. Allen Hynek. During that conversation Dr. Hynek gave me the basic details of the Delphos sighting. I immediately placed call to Sheriff Enlow and advised him that I would be in the area on Saturday morning, December 4, 1971. Sheriff Enlow offered to contact Mr. and Mrs. Johnson, which he did.

When I arrived at the small Kansas town of Minneapolis I found Sheriff Enlow in his office awaiting my arrival. We discussed the details of the case briefly and I was given a soil sample taken by Sheriff Enlow on November 3, 1971, the day following the alleged

landing. Sheriff Enlow and I then went to the Johnson farm which is located 11 miles north of Minneapolis.

When we arrived at the farm the temperature was 37° and the snow was melting. At the farm the condition of the lot was that of a bog. Mr. Johnson and Ronnie met us at the car and I was impressed with their sincere interest in the incident which had taken place there 32 days before. I began by talking with young Ronald. I would describe them simply as typical residents of the mid-west, having a rural background. The boy and his father are very pleasant and calm, not really excited by their unusual experience, but quite curious as to what the UFO may have been and what could have produced a ground marking such as the one found at the alleged landing site.

### THE WITNESSES

I discussed the observation with Ronald as long as the limited time would permit. He seemed sincere, and not too interested in UFOs or space flight. Ronald stated that he had read a few books on UFOs in the past. He said that it had been at least a year since he had heard or read anything on the subject. He stated that he had hoped to see a UFO someday but didn't believe that he would. To my knowledge there have been no UFO sightings in the central Kansas area during the last year. He did not at any time attempt to embellish his story with wild comments or theories. I believe that he tried very hard to answer each question correctly and to the best of his ability. Durel Johnson stated that he and Mrs. Johnson had indeed rushed outside to see the brilliant object in the southern sky. Unfortunately, neither Mr. Johnson or the boy were able to make any really sound estimates of the time periods during the observations. As they are not trained observers there were numerous details which they could not give with any certainty.

### GROUND TRACES

Following the discussion of the sighting we went to the landing site. In

(continued next page)

## DELPHOS, continued

order to reach the site one must cross the farm lot which by then was extremely muddy. The melting snow had left a great deal of standing water along with the mud. As we approached the site we walked around a small shed and through scattered trees. To my amazement there was the ring, with snow melting from the ground in all the surrounding area, still to be seen after 32 days. The ring was perfectly outlined by the unmelted snow. Although the surrounding soil was extremely moist, we found that if the snow was removed from any portion of the ring the soil directly beneath the snow was dry and light brown in color, in contrast with the black, moist soil in the ring center and around the ring.

We removed snow from one section of the ring and introduced water into the exposed ring area; the soil would not permit the water to pass through the surface. This was most remarkable, as there had been several inches of rain and snow between November 2 and December 4. Mr. Johnson and I next removed a sample from the ring. The sample contained a high concentration of a white substance, and this white material was evident in all of the ring soil that we exposed. The particles were not to be found in the soil in the center of the ring, or in the surrounding soil. The ring soil was quite dry to a depth of at least twelve inches. The soil outside the ring was also sampled and was simply black and wet to a depth of at least 8 inches. I cannot imagine soil exposed to the elements remaining so dry for such a long period of time.

### THE SITE

The site is located approximately 250 feet to the north of the farmhouse. The ground at the site is devoid of all plant life. A shed is located 23 feet from the center of the ring. The shed is 27 feet long and 4 feet high at the side towards the ring, and 5 feet high on the south side. A wooden fence 51 feet long runs west from the shed to the sheep shed where the witness stood. Ronnie stood at a point 10 feet south of the fence.

Between the ring and the shed is a dead tree, located 145° S. at a distance of 16 feet from the ring center. This tree was dead before the incident, but was standing. The stump is 7 inches high and 7 inches in diameter, and the break indicates that the tree may have been broken as the object made its descent along the assumed entry path. It appears that the tree was pushed towards the ring but fell, possibly due to suction on the eastern side of the trunk, at a right angle to the flight path. The fallen tree is 11 feet long and careful examination failed to reveal any marks at any point along its length. This tree could have been pulled over with a tractor and chain, however, one would expect to find chain marks. Sheriff Enlow and I discussed this possibility and feel that this was not the case.

Also adjacent to the flight path, one finds two 6-inch diameter trees, 125° South at 20 feet and 180° S. at 13 feet. The flight path would have been between these two trees. Their limbs extend towards the flight path and are 11 feet apart at a height of 12.5 feet above the ground. Two trees are located at 325° North at 5 feet from the ring center (1 ft. from the ring edge) and at 35° N. at 5 feet from ring center. These trees reportedly glowed and do show a slight discoloration on the ring side. A large broken limb was found still hanging at 260° W. a distance of 11 feet from ring center. The limb is broken at a point 8.5 feet above ground. The limb was broken downward, and the diameter at the break is 3 inches. When extended to its original position the limb would have been quite near the ring's edge. Close examination of this limb showed several possible impact marks. One mark in particular is of interest on a section of the limb which would have been very near the circle. About a 1-inch length of the bark was peeled back exposing a green surface. This area was definitely not a natural fault in the bark. This limb was alive at the time of the alleged landing, and it would have taken considerable pressure to have broken it.

Entry into the site would not have been possible to the north or east as those areas contain numerous undisturbed trees. A vertical descent or ascent would be out of the question as

the tree branches directly above the ring were not damaged. The broken limb did show what appeared to be heat blisters, while branches were green at the center but would snap at the slightest pressure. The flight path would appear to have been as Ronald described it: between two trees, over the fallen tree, over the low shed and to the south. An object with the dimensions described by the witness could have made its way into, and out of, the landing site. A landing by any conventional aircraft is completely out of the question.

After taking the appropriate measurements and photographs we returned to the house and discussed the observation briefly once again.

I then drove back to Delphos and talked with a representative of the Concordia Weather Bureau by telephone. He stated that the meteorologist had visited the site and made a check for radiation and that the results were negative. The meteorologist could offer no explanation for the ring and felt that it was indeed unusual.

I was given photographs of the site taken by the *Delphos Republican* November 3, 1971 and a small branch taken on the same day.

### SECOND TRIP

I decided that a second trip to the alleged landing site was necessary to obtain the needed information and to get the most accurate measurements of the site possible. I felt that the trip would be worthwhile if only to observe any changes in the ring.

I talked with Sheriff Enlow about the possibility of a hoax. We discussed this at length and both are of the opinion that a hoax would be most unlikely. I obtained a signed statement from Sheriff Enlow regarding the reliability of the witnesses. I quote his statement:

**"TO WHOM IT MAY CONCERN:**

"In reference to the UFO sighting at the Durel Johnson residence near Delphos, Kansas on November 2, 1971. The Johnsons are life-time residents of Ottawa County and the Delphos

(continued next page)

## DELPHOS, continued

Community. They are well known and well respected by Officers from this Department. It is the opinion of this Officer that the information given by them would be accurate to the best of their knowledge.

"In reference to the UFO sighting on November 2, 1971 by Mr. Lester Ernsbarger of Minneapolis, Kansas. Mr. Ernsbarger is an Employee of the Minneapolis Street Department and a reserve Police Officer with the Minneapolis Police Department. I feel that his information would be accurate to the best of his knowledge.

"Signed: Ralph Enlow, Sheriff, Ottawa County, Kansas."

After talking with Sheriff Enlow, I proceeded to Delphos where I stopped at the office of the *Delphos Republican*. I talked again with the Editor, Willard Critchfield and reporter, Thaddia Smith. I obtained a signed statement from Mrs. Smith as she had gone to the site on November 3, 1971, and obtained branch samples and photographs. I quote from her statement:

"After receiving information late in the afternoon of November 3, 1971, that personnel from the Ottawa County Sheriff's Office, Highway Patrol and the Cloud County Weather Bureau had visited the site and taken samples of the soil and trees, I, with my husband, returned to the Johnson farm that evening to secure further information they might have for my newspaper article concerning the mysterious UFO.

"The Johnson family, my husband and I, without lights, walked in the darkness to the site.

"We we came into view of the area we could see very distinctly the glowing ring. In the area around and inside the circle there was nothing but darkness giving a person an eerie feeling.

"The Johnson family having lived in the Delphos Community their entire life are respected, truthful, conscientious, trustworthy and a well-thought-of typical hardworking Kansas farm family.

Signed: Thaddia Smith, Reporter, *Delphos Republican*."

I then returned to the Johnson farm to find Mr. Johnson and Ronnie

working in the lot. The three of us went through the observation once again. The details were basically the same as given before. Mr. Johnson did mention that the dog avoided the ring on the evening following the sighting, and he would return to the area only after a number of people had visited the site the following day. Mr. Johnson stated that he had lived on the farm for the past 14 years, and the site has never had any structure on it.

The three of us went to the site and the ground which had been muddy on my previous visit was now dry. The ring was faintly visible as it was a slightly lighter color than the surrounding soil. We proceeded to "water down" the area with several buckets of water, and as we placed the water on the soil the ring became quite prominent. As the surrounding soil immediately absorbed the water it turned a dark black, but the ring soil would not admit the water and simply turned a lighter color. The water stood on the ring soil briefly and suddenly ran off the surface into a lower section of ground at the center, as it did so the surface appeared dry. It was as if the water had been poured on a glass surface.

We must remember that all this was taking place 71 days after the ring appeared. Mr. Johnson and I opened the ring in several areas, all were dry and contained the white substance. We were able to expose the soil to a depth of 14 inches, and it was still dry at that point. I opened the soil at the ring edge in order to see the normal soil meeting the ring soil from the surface to a depth of 6 inches (I did not go deeper at this point). The ring soil was dry with the white substance, the normal soil joining the ring was black, damp and did not contain the white material. On the western edge of the ring one finds an area which was not dried, and it contains none of the white material. The ring has an irregular diameter of 8 feet, and the ring width ranges from about 12 inches to over 20 inches. The greatest width is at the eastern side. This is interesting as it would have been down wind from the ring center, and it may be possible that the wind acted as a spreading agent.

After spending several hours at the Johnson farm I drove back to

Delphos and talked with Mrs. Johnson at a rest home where she works. Mrs. Johnson is a very pleasant, soft-spoken individual, sincere and intelligent. As they related the events of the evening of 11-02-71, she simply confirmed the information given us by Mr. Johnson and Ronnie. She did state that the object seen in the sky was quite large and bright and that it was moving away from them, growing smaller. She said that as she touched the ring soil minutes after the alleged ascent it felt cool, not at all warm. It felt strange; having a slick, crusty feel. She felt the numbing in her fingers and tried to remove the soil by rubbing her hand against her leg. That portion of the leg became numb also, this condition persisted for more than two weeks.

During my first trip, and during this visit as well, I attempted to meet Lester Ernsbarger who is a possible confirming witness. I have not been able to contact him as of January 16, 1972.

Another possible confirming witness is Elton Smith, Box 326, of Delphos, Kansas. Smith is employed at the Delphos Attendance Center as Principal-Educator.

Smith stated the following about the observation which took place at about 6:20 p.m. on November 2, 1971: "I saw *only* a streak of light coming downward, to the North of me (in the approximate Delphos area) as I was walking to the north from the school building to the football field in Bennington, Kansas. I did not see an object, but just thought it was a falling star."

As Smith observed the streak descending in the general direction of the alleged landing site just 40 minutes prior to the observation of the landed object, we might assume — and it would be pure conjecture — that Smith may have indeed seen the object on its landing path. If the streak was a meteor, it would have been quite bright as the sky was not in total darkness. As no object was seen, however, we certainly cannot consider this to be a confirmation of the Delphos UFO.

Lester Ernsbarger, a Minneapolis Street Department employee and reserve police officer, observed a bright

(continued on page 17)

## LETTERS

— Ridpath, Randles

Dear Editor,

I write to correct some of the mis-statements in Jenny Randles' article on the Rendlesham Forest case in the April issue of your Journal.

Firstly, I was not asked by the BBC ("Britain's state-owned TV Network," as she describes it) to produce an expose of the case. In making my own investigation, I learned that there were significant facts that the UFOlogists had not made public, and I took my story to the BBC's Breakfast Time programme, for whom I was at that time a science consultant.

Secondly, she charges that I invited myself into the audience at a subsequent Independent Broadcasting Authority debate on the case and "hogged a lot of air-time." In fact, the producers contacted me and invited me on to the programme to answer questions put to me by the presenter, which I did. In each case Randles' version is an inversion of the truth, and I have told her this in a personal letter.

Thirdly, her implication that media interest in Britain has been suppressed by pressure from above is fatuous. *The News of the World*, which ran the Rendlesham story, is owned by the same proprietor as *The Times*, which criticized it. The proprietor of *The Times* is not a Lord. He is Rupert Murdoch, a name not unknown in American newspaper circles. I would suggest the reason that *The Times* criticized the story is that their standards are higher than those of the *Enquirer*-like *News of the World*. Has Randles considered the possibility that the rest of the media refused to show any interest because they find the case no more convincing than I do?

Since I published my findings on the Rendlesham case, reprinted in your March issue, the tape recording made by Col. Halt in the forest has been made public. It confirms the conclusions in my article. Yes, the case has been solved for the past 18 months. That is

the one sentence in Randles' article that I agree with.

Fraternally,  
**Ian Ridpath**  
England

Dear Editor,

I must take the opportunity to reply to the letter sent by Ian Ridpath, commenting on my MUFON Journal article about the Rendlesham Forest, England, sightings.

On the question of his October 1983 BBC-TV feature. Mr. Ridpath called me *after* this was screened and I asked him why he had not contacted me about the case before making the item. He had known *for at least two years* of my involvement; through articles in the UFO media and lectures and discussions.

Ian Ridpath explained then that, as science consultant to that particular BBC morning programme, *they* had asked *him* to film a "different angle" on the story (these words are as close to accurate as I can recall them). Now, perhaps Ridpath lied at that time, to save face as to why he never checked with primary investigative sources. Or, as I interpret it, he may well have mooted the basic thought of an "expose" to them and they replied in the tone above. This allowed him to liberally avoid contact with anybody who knew anything at all about the case.

I fail to see how any investigative journalist can be satisfied with filming one forestry worker, who admits he had seen nothing and knew nothing about the case, but had found some rabbit holes in the forest a month or so later! Unless, of course, said investigative journalist has no interest in finding out what really happened, but rather wants to show the BBC he can demolish any UFO case he chooses (so long as things like the facts don't get in the way).

As to his appearance on the March

1985 IBA programme. I was told by the chief researcher the day before it went out that Ian Ridpath had "suggested himself to us" (her words). I have checked since, and been told that somebody else at the station may have contacted him before then, as they approached several dozen people as possible candidates. But they had selected myself and astronomer, Dr. John Mason, to appear on stage. Then Ian Ridpath had "pointed out his virtues" (which is, of course, his privilege, but shows how much he wanted to appear).

I can only tell you what I was told. If Mr. Ridpath disagrees with this then he presumably must be right and the person who told me the above at the TV station is not telling the truth, for reasons I cannot imagine.

In any event I certainly saw Ian Ridpath waylay the programme presenter the second she walked into the room to prepare for the show with Dr. Mason and I. He then spent many minutes clearly suggesting to her what the show should do. Again, his privilege. I am not disputing that at all.

Thirdly, Ridpath really is being silly if he attempts to make us believe that Rupert Murdoch runs the *News of the World* and the *Times*. He may be the financial power behind them, but each paper has distinctive editorial styles and very often disagree with one another 100 per cent! As for the story's suppression, I prefer to listen to the journalists who *told* me of their problems (such as TV producer Doug Salmon), rather than make assumptions (as Ian Ridpath does) based on his conclusion that the case is unimportant. He seems to have reached that view remarkably quickly and deductively, as he has never once interviewed a single witness of any description.

Would you dismiss a case on

(continued on next page)

## DOODLEBUG, continued

recognized the dollar potential of the doodlebug. Being by far the sharper of the two, he stepped into the lead role and the two soon serenaded Flader and associates to the melodious tune of a quarter of a million dollars.

Meanwhile, Newton mingled in Hollywood (he claimed to have known Bob Hope and Jack Benny, among others) with friends supplied by the trusting Scully. In 1947, while drilling an oil well in Wyoming, he had seen what he took to be a flying saucer and became deeply engrossed in the subject. With public interest in UFOs peaking, Newton's genius took the short step of connecting the doodlebug to flying saucers. He began to let on to Scully that he was privy to space-age technology derived from study of a crashed saucer, namely the doodlebug. When Scully wanted to know more, specifically to speak with one of the scientists who had examined the flying disc, Newton trotted out GeBauer, disguised as Dr. Gee.

## SCULLY REPORTS

Scully fell for the story, hook, line and doodlebug. Based on the information he received from Newton and GeBauer, he reported in his weekly column for October 12, 1949, that he had learned "all there is to know about flying saucers." In a second column, dated November 23, of the same year, Scully related the Newton story entire and said the saucers were known to have come from Venus. At some point he started work on *Behind the Flying Saucers*, later boasting in his autobiography that he completed the work in 72 days. "As you might imagine," said Moore, "that left him little time for any original research."

While Scully was at his typewriter, Newton continued working the links. A week after the appearance of Scully's second column, he wormed his way into a party at the Lakeside Country Club that included Bruce Cabot of *King Kong* fame. After the game and a couple of rounds of drinks, out came the saucer story along with the doodlebug, now a "magnetic radio," said by Newton to have been retrieved

from the crashed saucer. He also claimed to have pieces of the aliens' clothing and bits of the disc's metal gears. Cabot was suspicious enough to call in the FBI, which turned the tale over to the air force's Office of Special Investigations.

Thanks to OSI interest, an official memorandum to J. Edgar Hoover, the director of the FBI, was eventually generated, dated March 22, 1950, which has since been cited by some UFO researchers as evidence that the government does indeed have in its possession several crashed flying discs. "Had they bothered to check into the matter before jumping to conclusions," said Moore, "they would have realized that the original source of the story was Silas M. Newton, and that the document is essentially worthless."

## DOODLEBUG

So was Newton-GeBauer's doodlebug, which contained little more than a few lights and flashlight batteries, but certainly no advanced extraterrestrial technology. Following a couple of expose articles by J.P. Cahn in *True Magazine*, Newton and GeBauer were indicted and convicted of operating a confidence game. They were ordered to pay restitution and given suspended jail sentences, neither man serving time. At the time of his death, December, 1972, in Los Angeles, Newton's estate had more than 140 claims against it for a total of almost a million and a half dollars. GeBauer died similarly impoverished in Colorado, in late 1982.

Scully passed away in 1964 in California, maintaining to the end that Newton was a victim of circumstances, and that a flying saucer with Venusians on board really had crashed in the desert.

Apparently Newton took pains not to involve Scully directly in any of his financial shenanigans. "I'm convinced Scully was innocent in the affair and simply used by Newton," said Moore. "He was too valuable as a source of Hollywood contacts to risk alienating."



## LETTERS, continued

criteria like that?

Of course, what speaks volumes is that all Ian Ridpath can continually do is comment on minor points of no real importance. I could (if necessary) concede that he is right on every single one of the things he raises in his letter — and it would make not one jot of difference to the case. What he never does is answer my criticisms of his lighthouse/rabbits explanation. I wonder why?

Sincerely,

Jenny Randles  
England

## Dear Editor,

I have recently started research on UFO cases describing any alleged alien writing; symbols, words, communications, etc.. This includes automatic writing in an unknown language by persons involved in UFO cases. Since MUFON, CUFOS, and APRO are apparently not aware of anyone else who has done research in this area, I know little about how many such cases have been recorded. Perhaps your readers can help me.

Any examples of alleged alien writing, along with background data on the UFO case, would be greatly appreciated. The name and address of other known sources of such material will help. Please mail to me at 662 Fairway Avenue, Ft. Walton Beach, FL 32548 and include a bill for your copying/ mailing expenses. Perhaps, if enough data is obtained, I can prepare an article on the subject that would interest your readers.

Donald M. Ware  
MUFON State Director  
Florida



## JIGSAW, continued

preconception. When we ask whether the object moved erratically instead of posing a neutral question about its flight, we might as well announce ourselves as true believers and dispense with any pretext of objectivity.

One of the most frequently overlooked aspects of our investigations is the matter of collateral contacts. In how many cases would a check with neighbors have brought the reliability of the witness into question? How many times would a contact with the air traffic control tower have revealed an airplane or helicopter in the immediate vicinity? How often have we guessed at the altitude of cloud cover rather than asking the national weather service?

There is no mystery in why we do these things, why we conduct poor interviews and fail to follow up. Again, it is fed by a hefty portion of bias. We are too often lured by the prospect of admiration from our peers or publication of the account, and so we stop short of making all reasonable efforts to find an explanation.

## EXAM

Over the past year, MUFON consultants and state directors nationwide were asked to comment on separate drafts of a proposed field investigator's examination. There was overwhelming support for the concept of establishing such an instrument in order to measure investigative credentials, and scores of suggestions were made to improve it.

The exam covers twelve specific areas of science, technology, and human perceptions as related to claimed UFO observations, as well as major events and trends in modern UFO history.

Throughout the hundred questions in total, the test emphasizes an investigator's ability to distinguish between cases of mistaken identity and genuine UFO encounters. It is designed to be open-ended. The examinee can take whatever amount of time necessary and call upon any source of information for the answers. Over two-thirds can be readily found in a

dictionary or encyclopedia. The remainder are a matter of direct observations or comprise fundamental points by major authors on the subject. It will be administered to all MUFON investigators over the coming year.

Beyond the particular information afforded, the exam makes an overall statement to those who would present themselves to their communities as seriously interested in the proper evaluation of aerial phenomena. The message it conveys is that the position of field investigator is an earned privilege. Moreover, it allows all of us to read sighting reports in the future with the assurance that the author knows what he or she is talking about.

If we are to eliminate the cheap shots by debunkers and the snide remarks by the media, we must demonstrate more professionalism. It is, in the final analysis, our responsibility to silence the skeptics by putting our own house in order.

We can no longer afford to be a loose confederation made up of a few who have truly devoted their lives to this quest and a vast majority of fringe members. Whatever lies ahead, our commitment to excellence must be equal to the task. And that means every one of us.

## DELPHOS, continued

light in the sky towards Delphos at 7:30 p.m. No other details as of this date.

## SUMMARY

Based on the interviews with Mr. and Mrs. Johnson and Ronald, Sheriff Enlow and reporter Thaddia Smith, and after seeing the alleged landing site over a period of 71 days, it presents, I believe, considerable evidence which would seem to confirm the unusual event described by the witnesses. I would suggest that this may be a most significant report.

If one eliminates the observation of the object and the evidence found at the site, the ring remains, and this unusual ground mark is indeed a mystery. Although, according to the Concordia, Kansas, Weather Bureau, there had been several inches of rain and snow at the site, the ring soil remains extremely

dry and light brown in color. The contrast between the ring soil and the surrounding soil is incredible.

It is my belief, based on the information at hand, that we have here an excellent example of the unusual phenomena which has been reported by so many for so long.

### UFO NEWSCLIPPING SERVICE

The UFO NEWSCLIPPING SERVICE will keep you informed of all the latest United States and World-Wide UFO activity, as it happens! Our service was started in 1969, at which time we contracted with a reputable international newspaper clipping bureau to obtain for us, those hard to find UFO reports (i.e., little known photographic cases, close encounter and landing reports, occupant cases) and all other UFO reports, many of which are carried only in small town or foreign newspapers.

"Our UFO Newsclipping Service issues are 20-page monthly reports, reproduced by photo-offset, containing the latest United States and Canadian UFO newsclippings, with our foreign section carrying the latest British, Australian, New Zealand and other foreign press reports. Also included is a 3-5 page section of "Fortean" clippings (i.e. Bigfoot and other "monster" reports). Let us keep you informed of the latest happenings in the UFO and Fortean fields"

For subscription information and sample pages from our service, write today to:

UFO NEWSCLIPPING SERVICE  
Route 1 - Box 220  
Plumerville, Arkansas 72127

**MUFON**  
**AMATEUR RADIO NET**  
**EVERY SATURDAY MORNING**  
**AT 0800 EST (OR DST)**  
**ON 7237 KHz SSB**

## MESSAGE, continued

MUFON members with computer equipment who would be interested in participating in this growing communications medium, please contact Mike at The Compufon Network, P.O. Box 954, Duvall, Washington 98019 or the voice line (206) 788-5307.

The Compufon Network, Puget Sound Aerial Phenomena Research, The National UFO Reporting Center, and The UFO Information Service have entered into an agreement to publish a tri-monthly Journal. The Journal will be available to anyone who might be interested at no charge. To receive a copy of the first edition of the Journal, please send your request to the address in the prior paragraph of this article.

\* \* \*

**James W. Deardorff, Ph.D.**, MUFON Consultant in atmospheric physics, has taken a very serious interest in the validity of the Billy Meier photographic case, popularly known as "UFO: Contact from the Pleiades." During the month of June, Jim traveled to Schmidruti, Switzerland to interview Mr. Meier and to also interview other witnesses or witnesses to secondary events in order to evaluate the authenticity of the case for himself. Dr. Deardorff has submitted a "letter to the editor" commenting briefly on the Philip Mantle article in the Journal of June 1985 and references to the E. Meier case. We have invited Jim to submit a paper for publication in the MUFON UFO Journal elaborating upon what he learned that either substantiates Billy Meier's claims or identifies fallacies or both based upon his personal on-site investigation. Since the Elders have now published Volume II, with new photographs, this case is not closed as far as some researchers are concerned. We look forward with anticipation to Dr. Deardorff's personal evaluation, because he originally felt that there was considerable validity to the case and photographs.

\* \* \*

At the MUFON annual corporate meeting in St. Louis on June 30, 1985, **Joe Santangelo**, Director of the

(continued on next page)

## THE NIGHT SKY

By Walter N. Webb

MUFON Astronomy Consultant

October 1985

### Bright Planets (Evening Sky):

Jupiter and Saturn, the largest planets, can still be seen simultaneously at dusk—the former shining brightly in the SE, the latter (nearly 15 times fainter) very low in the SW. Resuming eastward motion on the 3rd, Jupiter appears due south at 8 PM Daylight Time in midmonth. Saturn sets about 7:30 PM in midmonth and disappears from sight by month's end.

### Bright Planets (Morning Sky):

Venus, brightest of all celestial objects except for the sun and moon, rises in the east 2 hours before the sun in midmonth. It approaches ruddy Mars on the 4th and 5th, appearing less than  $\frac{1}{2}^\circ$  from its much dimmer companion (Mars is 145 times fainter!). After that, the gap between the two widens so that Venus ends up  $16^\circ$  south of the red planet by month's end. Our brilliant neighbor planet is very near a thin crescent moon on the 12th.

Jupiter now sets in the WSW about 12:30 AM in midmonth.

### Meteor Shower:

Conditions are quite favorable this year for the peak of the Orionid meteors on the morning of the 21st. Since the first-quarter moon sets before midnight, observers may watch this shower as it reaches about 25 per hour toward dawn. These meteors are swift and mostly faint, although some are fireballs leaving persistent trains behind them. Viewers should be alert for enhanced activity due to the proximity of Comet Halley, from which the Orionid particles originate.

### Halley's Comet:

Halley closes to within 145 million miles of earth by midmonth, brightening to 10th magnitude and becoming accessible to observers with 3-to-4-inch telescopes. Rising then in the NE about 10 PM Daylight Time, the comet is visible for the rest of the night, achieving its highest altitude due south about 5:30 AM. On the 15th it lies  $\frac{1}{2}^\circ$  north of  $\text{Chi}^2$  Orionis at R.A. 6h 00m, Dec.  $+20^\circ 41'$  (1950 coordinates). Avoid interference from moonlight by looking for the comet around the middle of October.

### Moon Phases:

Last quarter--Oct. 7  
New moon--Oct. 14  
First quarter--Oct. 20  
Full moon--Oct. 28 (Hunter's Moon)

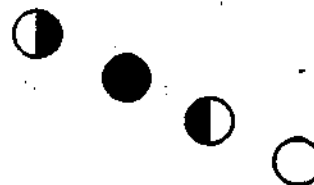

### The Stars:

At 9 PM in mid-October the nose of Pegasus the upside-down Flying Horse touches the celestial meridian (imaginary line through north-zenith-south

(continued next page)

**STARS & PLANETS, continued**

points). At that hour the Summer Triangle is still prominent high in the SW. Both the V-shaped Hyades and dipper-shaped Pleiades star clusters appear for the first time above the eastern horizon--a hint of the winter season yet to come.

Below Pegasus lies a portion of the sky called The Sea, occupied by the inconspicuous watery constellations of (from west to east) Capricornus the Sea Goat, Aquarius the Water Bearer, Piscis Austrinus the Southern Fish, Pisces the Fish, and Cetus the Whale or Sea Monster. The only bright star in this whole "aquatic" region is Fomalhaut, a white first-magnitude star in the Southern Fish; it is the southernmost bright luminary seen from northern latitudes.

The Big Dipper, following its counterclockwise path around the north celestial pole as the earth rotates, skims along the northern horizon at this season. This popular asterism never goes below the horizon for latitudes above 40°.

**MESSAGE, Continued**

MUFON Amateur Radio Net submitted his activity report for the first half of the year. This net meets every Saturday morning on 7237 KHz at 8:00 a.m. Eastern Time. Radio propagation conditions varied considerably plus interference from other ham stations, directly influencing the number of stations reporting into the net each Saturday. For the first six months, the weekly average was eleven with a high of 15 stations checking in and a low of 7 each week. Again, our thanks to Joe, N1JS, WA3QLW, and Dave, W8NQN for sharing the net control station responsibilities. On March 2nd, your International Director operated KE5QW, belong to **Paul Littlejohn** in Seguin, Texas, and thus had the privilege of reporting into the net. A long skip that morning made solid communications with all stations difficult.

\* \* \*

**Ann Druffel**, Contributing Editor of the Journal, was very concerned when she noted in a recent letter to the editor by Hilary Evans, stating that Flying Saucer Review (FSR) was folding. (This could have occurred due to the failing health of Charles Bowen - Director's (Note.) Mrs. Druffel called Gordon Creighton in England to determine the status of FSR and found that it was alive, well, and proceeding on schedule. Your Director has been in correspondence with Gordon Creighton, since he became the Editor of FSR and I confirm Ann's information. Mrs. Druffel was recently concerned when she read the unpleasant news in Mr. Evan's letter. The Flying Saucer Review is considered by some to be the finest UFO magazine in the world. FSR is highly recommended to the readers of the MUFON UFO Journal and to anyone interested in the world scene.

**STATEMENT OF OWNERSHIP, MANAGEMENT AND CIRCULATION**

- 1. Title of publication: MUFON UFO JOURNAL (USP 002970) (ISSN 0270-6822)
- 2. Date of filing: Sept. 23, 1985
- 3. Frequency of issue: monthly
- 4. Location of known office of publication: 103 Oldtowne Road, Seguin, Guadalupe, Texas 78155-4099
- 5. Address of the headquarters: 103 Oldtowne Road, Seguin, TX 78155-4099
- 6. Names and complete addresses of publisher, editor, and managing editor:  
 Publisher: Walter H. Andrus, Jr., 103 Oldtowne Road, Seguin, TX 78155-4099  
 Editor: Dennis W. Stacy  
 P.O. Box 12434, San Antonio, TX 78212
- 7. Owner: MUTUAL UFO NETWORK, INC. (MUFON), 103 Oldtowne Road, Seguin, TX 78155-4099

A not-for-profit corporation incorporated under the State Laws of Texas.

The Mutual UFO Network, Inc. is exempt from Federal Income Tax under Section 501(c)(3) of the Internal Revenue Code. MUFON is a publicly supported organization of the type described in Section 509(a)(2).

8. Known bondholders, mortgagees, and other security holders owning or holding 1 percent or more of total amount of bonds, mortgages or other securities: NONE

9. For completion by nonprofit organizations authorized to mail at special rates: Publication is issued by an organization eligible for these rates in accordance with Section 423.12 DMM.

10. Extent and nature of circulation:

	Average No. copies each issue during preceding 12 months	Actual No. copies of single issue published nearest to filing date
A. Total No. copies printed .....	1377	1375
B. Paid circulation		
1. Sales through dealers and carriers, street vendors and counter sales .....	0	0
2. Mail subscriptions .....	1185	1171
C. Total paid circulation .....	1185	1171
D. Free distributions by mail, carrier or other means: samples, complimentary, and other free copies .....	72	73
E. Total distribution .....	1258	1244
F. Copies not distributed		
1. Office use, left over, unaccounted, spoiled after printing .....	119	131
2. Returns from news agents .....	0	0
G. Total .....	1377	1375

(signed) Walter H. Andrus, Jr.  
 Publisher



# DIRECTOR'S MESSAGE

by  
Walt Andrus

The first "National UFO Information Week" was a successful event in a majority of our states where participation was the key to measuring its effectiveness. The answer to "where have all the UFOs gone?" in the news media was dramatically addressed in the form of exhibits, TV documentaries, radio and TV talk shows, one-day UFO seminars, etc. After the State Director's activity reports are received by **Marge Christensen**, MUFON Public Relations Director, fresh plans will be devised for 1986. Mrs. Christensen is to be complimented for having originated and implemented this unique program to make the public aware of the UFO phenomenon.

\* \* \*

**Donald M. Ware**, State Director for Florida, has appointed **Juan Manuel Quiros** of Miami to become the new State Section Director for Dade and Monroe Counties replacing **Irving Lillien**, Ph.D. Dr. Lillien will continue as a Consultant in Chemistry.

**Bruce A. Widaman**, State Director for Missouri has approved the appointment of Jim Middleton to be the State Section Director for St. Francois and Ste. Genevieve Counties and a Research Specialist in Clinical Psychology. Mr. Middleton has an M.A. in Clinical Psychology and a B.A. in Administration of Justice.

Since the success of MUFON may be directly attributed to the leadership of the State Directors, we are searching for people who would be interested in filling vacancies in the states of Alaska, Montana, North Dakota and Puerto Rico. Several existing State Directors have realized that they do not have adequate time, have health problems, or new job responsibilities, preventing them from fulfilling their MUFON-assigned duties adequately and have asked your Director to seek replacements for them. We need people to volunteer to become State Directors in Colorado, Kansas,

Oregon, Nevada and West Virginia. Please write to MUFON in Seguin, Texas, indicating your sincere interest and qualifications. Many of our State Directors have not selected an Assistant State Director to share their administrative duties, which we encourage and recommend. We are in the process of revising our TELUFONET, so it is imperative that we have enthusiastic state leadership in every state.

\* \* \*

**James R. Leming**, a former State Section Director in Montana, and just recently the former editor of the "S.B.I. Bulletin," has rejoined the MUFON UFO JOURNAL as a staff artist. Many of our readers can remember Jim's professionally done illustrations that have graced the cover of the Journal and UFO sighting reports. We welcome Jim back to the staff where he joins **Simone Mendez**, who will be moving from Las Vegas, Nevada to Oklahoma City.

**Dan Wright** and his host committee are continuing their planning for the seventeenth annual MUFON UFO Symposium at Michigan State University in East Lansing, Mich. for June 27, 28, and 29, 1986. Additional speakers will be announced as they are confirmed. **John F. Schuessler** is the latest to be announced. The MUFON 1985 UFO Symposium Proceedings, emphasizing the theme "UFOs: The Burden of Proof" are now available from MUFON in Seguin, Texas for \$10.00 plus \$1.50 for postage and handling (180 pages). All foreign orders must be by International Postal Money Order or cash in U.S. dollars.

A sad announcement appeared in "The APRO Bulletin" Volume 33, No. 1 published in July 1985, which may signal the demise of the Aerial Phenomena Research Organization. So that there will be no misunderstanding this announcement is hereby quoted verbatim.

"Dear Members and Subscribers:

With this issue of the APRO Bulletin publication will be suspended for an indefinite period. It will be resumed just as soon as the health of the editor will permit. As you may know, health problems in the Lorenzen family have been the main cause of delayed publications in the recent past. Mrs. Lorenzen's doctors have strongly advised that she take a complete rest for several months. Therefore it will be impossible for her to devote sufficient energy to the task of turning out a quality publication.

There are those of you who may wish to keep your subscription in force until conditions return to normal. Some of you may choose to terminate your affiliation. In this case APRO is offering back issues from available stock at a valuation of \$ .50 each against remaining credit. Symposia papers can also be selected to offset extant credit at regular rates. See Bulletin cover for prices.

This step is a very painful one, as the subject for our mutual interest remains one of greatest importance, even after 32 years of study. You are all urged to continue your reading, searching, and where possible, reporting events that take place in your areas.

Many thanks for your faithful support.

Coral and Jim Lorenzen"

\* \* \*

The Compufon Network Newsletter for August 1985 addresses several pertinent points in the Director's Comment by **Mike Hart**. The cost for producing the monthly newsletter plus three dedicated telephone lines will necessitate that annual dues must be charged because the Director and a few founding members cannot continue to absorb these monthly expenses. For those

(continued on page 18)

# MUFON UFO JOURNAL

NUMBER 210

OCTOBER 1985

Founded 1967

OFFICIAL PUBLICATION OF



MUTUAL UFO NETWORK, INC.

\$1.50



## NATIONAL UFO INFORMATION WEEK

**MUFON UFO JOURNAL**  
(USPS 002-970)  
(ISSN 0270-6822)  
103 Oldtowne Rd.  
Seguin, Texas 78155-4099

**DENNIS W. STACY**  
Editor

**WALTER H. ANDRUS, JR.**  
International Director and  
Associate Editor

**THOMAS P. DEULEY**  
Art Director

**MILDRED BIESELE**  
Contributing Editor

**ANN DRUFFEL**  
Contributing Editor

**TED BLOECHER**  
**DAVE WEBB**  
Co-Chairmen,  
Humanoid Study Group

**PAUL CERNY**  
Promotion/Publicity

**MARGE CHRISTENSEN**  
Public Relations

**REV. BARRY DOWNING**  
Religion and UFOs

**LUCIUS FARISH**  
Books/Periodicals/History

**ROSETTA HOLMES**  
Promotion/Publicity

**T. SCOTT CRAIN**  
**GREG LONG**  
Staff Writer

**JAMES LEMING**  
**SIMONE MENDEZ**  
Staff Artists

**TED PHILLIPS**  
Landing Trace Cases

**JOHN F. SCHUESSLER**  
Medical Cases

**LEONARD STRINGFIELD**  
UFO Crash/Retrieval

**WALTER N. WEBB**  
Astronomy

**NORMA E. SHORT**  
**DWIGHT CONNELLY**

**DENNIS HAUCK**  
**RICHARD H. HALL**  
**ROBERT V. PRATT**

Editor/Publishers Emeritus

The MUFON UFO JOURNAL is published by the Mutual UFO Network, Inc., Seguin, Texas. Membership/Subscription rates: \$15.00 per year in the U.S.A.; \$16.00 foreign in U.S. funds. Copyright 1985 by the Mutual UFO Network. Second class postage paid at Seguin, Texas. POSTMASTER: Send form 3579 to advise change of address to The MUFON UFO JOURNAL, 103 Oldtowne Rd., Seguin, Texas 78155.

# FROM THE EDITOR

On the cover, Mayor Betty Jean Jones of Seguin (seated), proclaims National UFO Information Week. Standing, from left to right, are MUFON's International Director, Walter Andrus, Jr., Sandra Pfullmann, Staff Video Technician, and State Section Director, Rev. Anthony Neugebauer. Inside, Marge Christensen reports on similar activities from around the globe and across the country during the week of August 18-25, 1985.

Former Editor Richard Hall contributes an index by author of articles that have appeared in the annual Proceedings from 1980 until 1984. A subject index will follow in the next issue. Aside from our regular features we have an interesting article by new Staff Writer T. Scott Crain, several illustrated sightings, and an interview with pictures of Dr. Richard F. Haines, all of which we hope you'll find illuminating. In the meantime, the Letters section of the Journal is always open to your suggestions and comments. We look forward to hearing from you.

## In this issue

UFO LIFTING POWER, by T. Scott Crain .....	3
NATIONAL UFO INFORMATION WEEK, by Marge Christensen .....	5
PENNSYLVANIA CLOSE ENCOUNTER, by Stan Gordon .....	8
SIGHTINGS .....	9
RICHARD HAINES: AN INTERVIEW, by Dennis Stacy .....	12
PROCEEDINGS INDEX BY AUTHOR, by Richard H. Hall .....	16
THE NIGHT SKY, by Walter Webb .....	18
CARTOON, by Golliver .....	19
DIRECTOR'S MESSAGE, by Walt Andrus .....	20

The Mutual UFO Network, Inc. is exempt from Federal Income Tax under Section 501(c)(3) of the Internal Revenue Code. MUFON is a publicly supported organization of the type described in Section 509(a)(2). Donors may deduct contributions from their Federal income tax. In addition, bequests, legacies, devises, transfers, or gifts are deductible for Federal estate and gift tax purposes if they meet the applicable provisions of Sections 2055, 2106, and 2522 of the code.

The contents of the MUFON UFO JOURNAL are determined by the editor, and do not necessarily represent the official position of MUFON. Opinions of contributors are their own, and do not necessarily reflect those of the editor, the staff, or MUFON. Articles may be forwarded directly to MUFON. Responses to published articles may be in a Letter to the Editor (up to about 400 words) or in a short article (up to about 2,000 words). Thereafter, the "50% rule" is applied: the article author may reply but will be allowed half the wordage used in the response; the responder may answer the author but will be allowed half the wordage used in the author's reply, etc. All submissions are subject to editing for style, clarity, and conciseness. Permission is hereby granted to quote from this issue provided not more than 200 words are quoted from any one article, the author of the article is given credit, and the statement "Copyright 1985 by the Mutual UFO Network, 103 Oldtowne Rd., Seguin, Texas" is included.

# UFO LIFTING POWER

By T. Scott Crain

On the evening of October 15, 1983, 67-year-old Catherine Burk was driving home to Bellwood from Altoona, Pennsylvania after a visit with her family. While traveling north on Route 220, she noticed a bright object in the sky out the passenger side window. As it hovered closer, she could see it was a bright, silvery disc, about 24 feet in diameter, moving in a flight path directly above her car. The disc wasn't more than 30 feet off the ground and was emitting a sharp, fast hum.

Suddenly, as the UFO passed overhead, the passenger side of her 1976 Chevrolet Malibu was lifted up on two wheels, approximately three feet above the road. The left side of her car remained in the air for almost three seconds before the UFO moved away, dropping her car back on the road with a bounce. "I couldn't get control of the car. I was sliding over the seat," Mrs. Burk said. She was flung under the dash when her car came down. When she finally regained control of the vehicle, she pulled off the road. The UFO continued its flight in a northwesterly direction and disappeared behind a ridge. It took 20 to 25 minutes for Mrs. Burk to restart the car, and it shut off several times on her trip home.

## SOBER

Bellwood Police Chief Gregory Ciaccio investigated and found Mrs. Burk "visibly shaking" and "...was not drinking. The witness appeared to me to be sincere and honest, and not one to concoct a story such as this."

As a result of Mrs. Burk being jarred in her car, she has been treated at Mercy Hospital in Altoona for a number of physical injuries. These include a neck brace she was still wearing three weeks after the incident, a bruised shoulder, spinal problems, possible chest injuries and a loss of hearing in the right ear. Mrs. Burk wants to put this experience behind

her.

The irony of this incident is that what happened to Catherine Burk will probably happen again. A number of reports are on file where UFOs have exerted an uplifting force on motor vehicles as well as other objects.

A government topographer experienced a similar episode while driving on the Andean Highway between La Victoria and El Vigia, Venezuela on January 1, 1961. The details of the incident were recorded in the September 1961 issue of the APRO Bulletin in which Horacio Gonzales' account of what happened appeared in the lead article, "Disc Upsets Truck."

"Mr. Paolini pulled off to the extreme right of the road and the truck passed on towards the front. In this position both vehicles continued for a few minutes when, suddenly like a bolt from the blue, a brilliant object in the shape of a metallic disk, looking as though made from polished blue steel, swooped down from the sky at incredible speed and crossed perilously close over the front end (hood) of the truck. It then rose immediately in soaring flight at the same fantastic speed and was lost to sight in space in a matter of seconds in the opposite side of the sky. When the discoidal object rose into the air above the hood of the truck, the vehicle also rose a few feet into the air and overturned in the direction taken by the object — fortunately into a sand-bank at the side of road — with its four wheels upturned in the air. Controlling the fear and astonishment which seized him, Mr. Pisani stopped the jeep and rushed to assist the occupants of the truck. Luckily, the driver was the only occupant and escaped with only a few scratches, bumps, minor cuts and nervous shock. They then both went in search of other

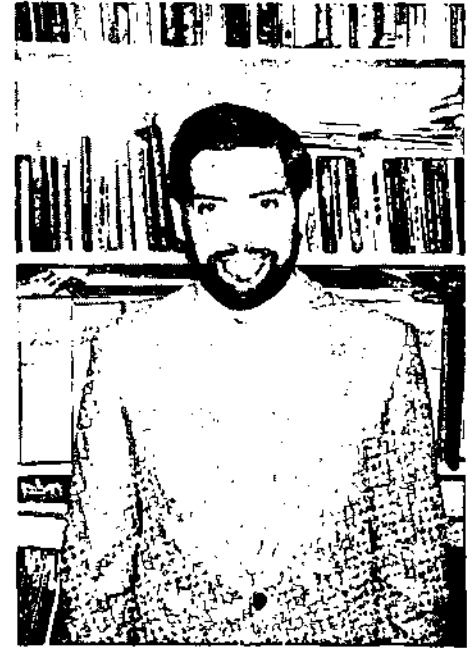

T. Scott Crain

people to help right the truck and get it back into operation."

## TORQUE

In some cases, as in the previous one, UFOs cannot only lift a vehicle off the road, but also impart a torque, or turning force, to an object in the same direction the UFO leaves the scene. A splendid example illustrating this type of maneuver is reported on page 50 of the NICAP book *Strange Effects From UFOs* by Gordon Lore. According to Lore:

"It was 11:45 p.m., December 20, 1965. Edward A. Bruns was driving his father's 1962 Ford pickup truck home. As he was heading west, south of Route 27, near Herman, Minnesota, he saw a bright, oval-shaped object hovering several feet above the road. The large UFO 'covered the entire road' and was shaped like two saucers with a dome on top. A

(continued next page)

## UFO LIFTING POWER, continued

window-like structure surrounded the dome. A green light was emitted from the window.

Suddenly, the truck engine stopped, the headlights went out, and the vehicle was spun violently to the right."

When the vehicle finally coasted to a stop, the truck was on the south side of the road, now facing east, resting in a ditch. According to Lore's report, Bruns watched the UFO emit sparks from its under-carriage, ascend and disappear.

The human body is not immune to the forces that some UFOs exert. On October 8, 1954, a resident of Teheran testified he was on the second floor of his house when he saw a glowing, white object stop in mid-air 60 feet away. "I was standing with both hands on the bar of my balcony, when I suddenly felt as though I were being drawn up toward the object by a magnet," reported Ghaseme Fili, of Amireah Street. Fili screamed in terror at the odd sensation. The UFO shot up vertically, emitting sparks, and vanished into the air.

Another extraordinary case occurred on March 8, 1967 to Mr. and Mrs. William L. Wallace while they were driving home to Leominster, Massachusetts. Shortly after midnight, the Wallaces noticed a large bright glow hovering about 400 to 500 feet above St. Leo's Cemetery, so they investigated. Again, Lore writes:

"Wallace told Raymond E. Fowler, of NICAP's Massachusetts Subcommittee, that he stopped his car, placed it in neutral gear and put the emergency brake on, with the motor still running. He lowered the windows. Then he got out and pointed toward the UFO. As he did so, his arm was pulled abruptly against the roof of the automobile. His car then stalled; the headlights went out and the radio ceased playing.

"I was unable to move," he said. "My wife was in panic. My mind was not at all affected. (I) just could not move, felt like shock or numbness."

"When the car went dead," Mrs. Wallace stated, "I was yelling

for Bill to get back into the car, but he did not move from where he was standing. I then slid across the seat and reached for him."

"Mrs. Wallace grabbed her husband's jacket, but the startled witness, who has a reputation for being fearless, did not move. Wallace reported that he was in this immobile state for more than 30 seconds. Then he noticed that the lights and radio came back on. The UFO, which, by then, was rocking back and forth, sped upward and disappeared, emitting a humming sound."

## CANADIAN CASE

A UFO kidnapping was averted in an incident in Thompson, Manitoba, Canada in June, 1967. It was 6:00 p.m.; it lasted only three or four minutes, and was observed by Mr. and Mrs. D.F. LeMarquands, three of their children, two other children, and four neighbors. Details of the encounter appeared in a Canadian UFO publication, *Saucers, Space and Science* (number 52, 1968), edited by Gene Duplantier.

Duplantier reports:

"Mrs. LeMarquands had just entered the house when she heard a beeping noise at about one second intervals. Looking out the window, she saw dirt and debris moving rapidly around the house in a circular pattern. Upon going outside, she saw her husband who had just driven into the yard. He and the five children were staring up into the sky.

At first only dust and dirt, moving in a vortex could be seen, but then Mrs. LeMarquands was able to see the object causing the disturbance. She described the object as being large and shaped much like a pack of cigarettes although she later commented that it might have been cube-shaped. It was revolving counterclockwise and appeared to have alternative shiny aluminum and then black sides as it moved. It had no apparent openings or lights, and it was dead silent.

As she watched the object, Mrs. LeMarquands was distracted

by a scuffing sound and she looked to the ground to see a 13-year-old boy from across the street pinning down her 8-year-old daughter. At this time the object started moving off at a 45-degree angle, leveled off, hovered, and then left on a level course toward the southeast.

Mrs. LeMarquands' attention was then drawn toward the children, all of whom were visibly shaken, except her 8-year-old daughter. The whirlwind had stopped and the little girl was not standing by herself. The other children were eventually sufficiently calm in order to say that their 8-year-old playmate had risen into the air toward the slowly revolving object. The 13-year-old boy had grabbed her when she was about three feet off the ground. The children reported that the little girl's skirt, blouse, and hair had ridden straight up her body when she was rising. When asked if she could remember anything, the girl replied that she could remember nothing from the instant the wind started until she stood up."

## ANIMALS, TOO

Animals have not been excluded from the uplifting forces of UFOs. In his book, *Ufology—New Insights From Science and Common Sense*, James McCampbell writes:

"A Frenchman remained outside the hazardous zone although his horse did not. He was leading his mare with a bridle when a UFO took off from the side of the road and flew overhead. The mare rose about 3 meters into the air and the witness had to release the bridle. After falling back to the ground, the animal could not move for about 10 minutes."

What is the significance of these kinds of UFO reports? Are the UFO operators purposely executing unusual physical encounters on mankind or do they happen merely as a result of vehicles, animals and people coming too close to a UFO's propulsion system? Of course, we don't know the

(continued on page 16)

# UFO INFORMATION WEEK

By Marge Christensen

Thomas Jefferson once said, "Ignorance is preferable to error; and he is less remote from truth who believes nothing, than he who believes what is wrong." Anyone who has done any public information on the UFO subject knows just how valid this statement is. If the general public were merely ignorant of the documented evidence and data on the UFO subject, the situation would not be nearly so difficult to correct. However, thanks to the tabloids working overtime to promote wild, sensational UFO-related stories with absurd, screaming headlines attracting the eye of just about every person in the country who ever shops at a supermarket, our job is that much more difficult. The bottom line is that the public is not uninformed; it is severely misinformed.



## MISINFORMED

Every one of us who has presented UFO lectures to civic organizations has had to deal with such misconceptions as: "If UFOs are being sighted everywhere, why are there no photographs of them? Why are they only sighted in deserted rural areas? Why have no pilots or astronauts ever reported UFO sightings?" It became even more graphically evident to me just how misinformed the public is when I was recently asked by a professional person with a college degree if I thought that perhaps the "aliens" had brought the disease AIDS here in order to force humans to behave better!

It is this misinformation that largely contributes to the stigma which has come to be attached to the UFO subject. One can hardly blame the average person for being somewhat hesitant to put his/her name on the dotted line of a membership application in a UFO research organization, if his only exposure to the subject has been provided by the media, and mainly by the sensational-type articles.

## UFO Week Not Just Hot Air

With all of this information in mind, one can hardly dispute the enormous potential value of a nationwide effort to inform the public about the serious data and documentation which exist on the UFO subject, and about the need for concentrated scientific study of the phenomenon. It was from this standpoint, then, that I first proposed that we conduct a National UFO Information Week which would be held in the summer of 1985.

The reports which have been received from the various MUFON State Directors regarding the observance of the Week in their respective states have indicated clearly that the first National UFO Information Week far exceeded our expectations. The following extracts from some of the reports are largely representative of the majority of the reports received:

## RESULTS

Stan Gordon, of Pennsylvania comments: "...National UFO

Information Week was an overwhelming success in Pennsylvania. We received extensive radio, tv, and press coverage from many sections of the state....Pittsburgh's major paper, the Post Gazette, ran a feature news story with front page header which had an unbelievable response. We had phone calls day and night for 4 days from people who had sightings but did not report to anyone." (That night a Pittsburgh TV station did a full feature story mentioning MUFON, and the response was so great that they were besieged with calls, and continued to voluntarily display the UFO hotline telephone number on later newscasts.) "What a change in attitude from the public. We saw little if any hard skepticism, with the people now willing to listen and believe. Most felt that the government was hiding the facts."

From Iowa, Donald Curtis reports that although he had to cover the entire state singlehandedly, and although he

(continued next page)

## UFO WEEK, continued

expended hundreds of hours and a like amount of personal funds, he feels that National UFO Information Week was a great success for him and for MUFON. Seven new cases have been referred to Don, and he also has received a number of applications for membership from interested persons, so he may not be working singlehandedly next year.

Francis Ridge, PR Director for Indiana writes, "Several member/investigators were signed up as a result of the publicity and there is even a newspaper in Ft. Wayne, the Fort Wayne Sentinel, that is doing UFO articles with our help. This was the worst year for UFO reports on our computer log until the publicity. We now have 19 entries, mostly older reports, but good ones."

In Oklahoma, Norma J. Waller, also working singlehandedly, managed to get excellent press coverage and radio coverage. In Hawaii, Dr. Michael Brein, also working alone, succeeded in getting great press coverage, including a front page article.

Similar reports of very positive tone have been received from Michigan, Northern California, Utah, New York, New Jersey, Wisconsin, Florida, North Carolina, Georgia as well. In New Jersey, Tom Benson reports that he distributed over 700 MUFON flyers from their display at a shopping mall. Tom also obtained over 100 signatures of persons interested in being placed on a mailing list for information on upcoming UFO events and conferences.

In Massachusetts, the UFO Forum was successful beyond all expectations, drawing persons from 17 States and resulting in extensive press, radio and television coverage. A segment for the program, "Evening Magazine" was videotaped at the Forum, and was recently aired. The tone of the presentation is totally positive and the subject and UFOlogists are both portrayed in a serious light. This film will be shown at the 1986 Symposium at Michigan State University. As was the case in other States, Mass. MUFON also received several sighting reports as well as several membership applications as a result of the events of

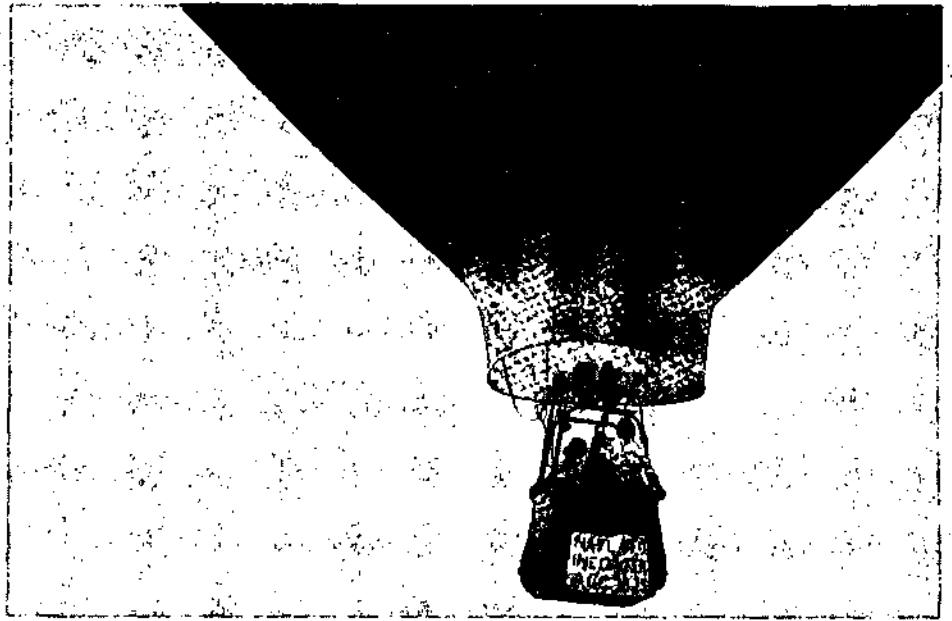

Up, Up and Away!

the Week.

Even on the other side of the globe, in Zimbabwe, Africa, Cynthia Hind, MUFON's Continental Coordinator for Africa, was hard at work running a UFO Information Week in that country. Cynthia reports that she had a stand at the Harare Show, amidst some industrial exhibits. She also gave a lecture on the UFO subject for one of the leading newspapers there. She commented that the people who attended the lecture were desperate for UFO literature.

The locations are different, but the story seems to be the same throughout the country and even in Africa. People are misinformed on the UFO subject, but once the misconceptions are corrected and people are presented with solid, serious information which is well documented, they are not only receptive to the subject, but are fascinated by it. Thus, it is vitally important that we continue our public information program. We will hold our second National UFO Information Week in the summer of 1986, but in the meantime, we cannot afford to take an extended vacation from this endeavor. As Dennis Stacy stated in the August, 1985 *MUFON Journal*, "UFOs don't take vacations; why should we?"

### PUBLIC

The stakes are too high to slack off

at this point in our public information effort. An informed public could, and should result in forcing the media to offer more objective, serious coverage of UFO-related news stories. An informed public will certainly make a government cover-up of the subject much more difficult. An informed public should result in a vastly increased number of sightings reported to the major UFO research organizations. An informed public will also hopefully effect a change in the respectability status of the subject on the university campuses and a more involved participation on the part of university research departments in serious investigation into the UFO phenomenon. In short, an informed public is a goal that every serious UFOlogist should be striving toward, and should be enthusiastically supportive of, at the very least.

Interestingly, as a result of our experience with our first attempt to conduct a National UFO Information Week, we have only achieved positive results as far as the public is concerned, but we have also apparently made some significant strides in improving our own professional image and our own preparedness. As a result of the deep commitment and generosity of many of our State Directors, Asst. State Directors, and Section Directors, several MUFON organizations now

(continued next page)



Pennsylvania Mall Display

### UFO WEEK, continued

have free-standing display panels as well as computers, a myriad of investigative tools and types of equipment, and other items such as VCRs, video-cameras, etc. In addition, through the efforts of Walt Andrus, several persons who were previously holding titles, but not performing, have been replaced by others who are energetic and dedicated.

There is a steady stream of mail coming into this office from State Directors around the country reporting on their public information endeavors or seeking information for use in their endeavors. Every weekend an average of 4-8 phone calls come in from around the country from State Directors, and others concerned about keeping informed, and actively performing public education on the UFO subject. I have generated literally thousands of pieces of correspondence over the past year in regard to public information and have made hundreds of phone calls nationwide for the same purpose.

This has all resulted in a very active and efficient communications network, and in a level of organization in our field which older colleagues tell me is far greater than any organizational level ever achieved in UFOlogy in the past. Coordinating a nationwide information

week has made this level of organization imperative, and this will continue to be the case since National UFO Information Week will become an annual event. This result on our own investigative network has been one of the most significant and most constructive benefits we have enjoyed as an indirect result of National UFO Information Week.

Furthermore, the image we have

been attempting to project of ourselves as "voluntary professionals" rather than as mere hobbyists, has apparently paid off. This office has received numerous newspaper clippings from coast to coast in regard to coverage during National UFO Information Week. Without exception (to date), the press coverage in these clippings has been on a positive note. Both articles and headlines have portrayed the UFO subject, UFO sightings, witnesses, and UFO investigators and organizations in a straightforward, objective manner, with no sarcasm or ridicule. Both the press and UFOlogy have progressed a long way in this regard.

We have begun to make a miniscule dent in public misinformation on the subject. Our task is far from complete. However, because of the accomplishments we have made this year, we should find the task a bit easier next year, and in the subsequent years ahead.

In summary, National UFO Information Week was a worthwhile project which should definitely be repeated in 1986. The dates for National UFO Information Week, 1986 will be August 10-17, 1986. It is not too early to start making preparations for your State's programs and events for

*(continued on page 16)*



Iowa Mall Display

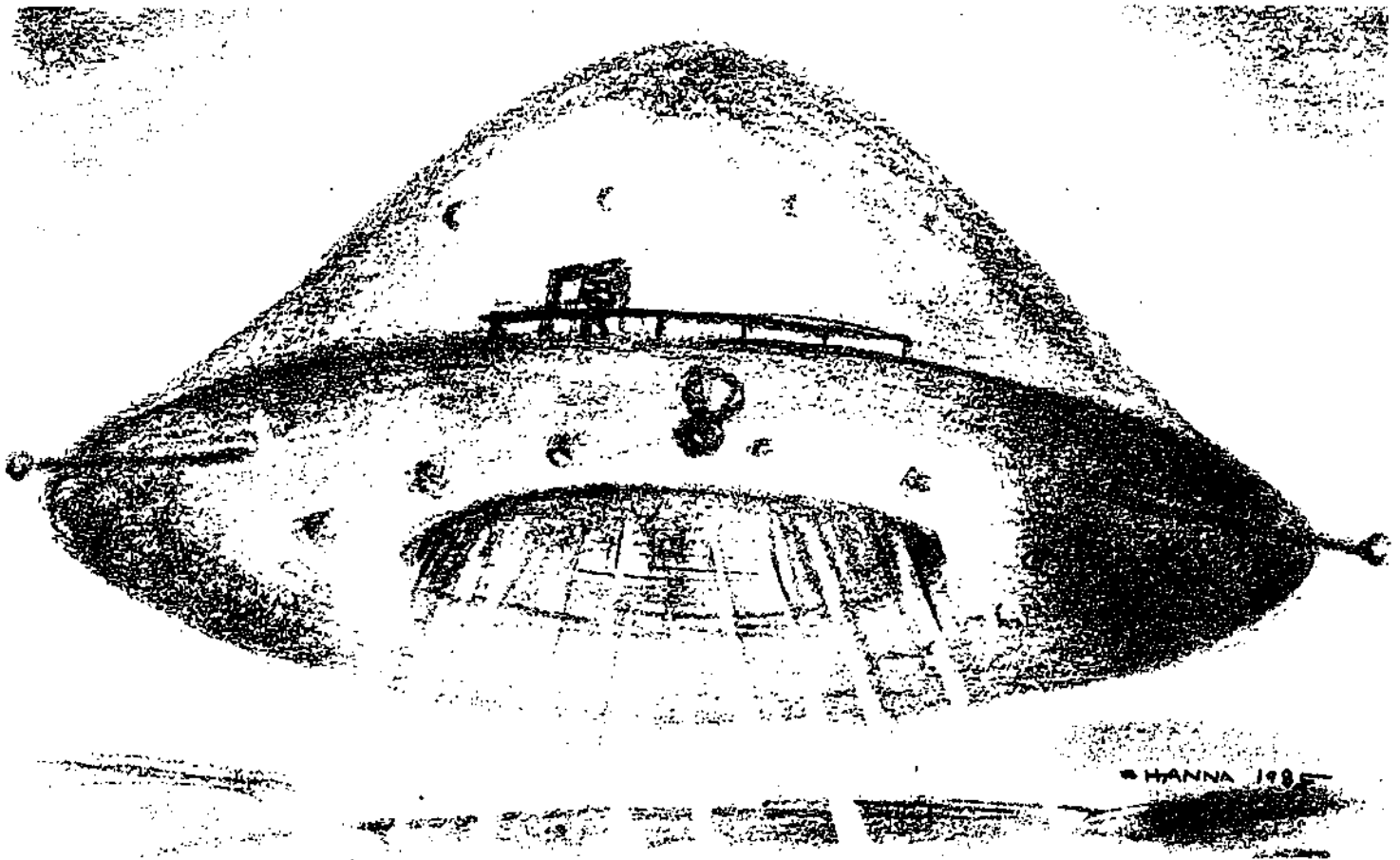

## PENNSYLVANIA CLOSE ENCOUNTER

By  
Stan Gordon

Bob and Sue (real names on file) recently married and moved into a small cozy house in a rural area near the village of Mutual in Westmoreland County, PA. It was February of 1968, and snow had been falling during the early evening.

It was about 11 PM and Bob was in the bedroom preparing to go to sleep since he had to awake early for work. He pulled back the drapes to check the road conditions and was astounded by what he saw.

### PROBE

Next to the house about 30 feet away is a large fishing pond, and hovering near it was a huge oval-shaped object. What first caught Bob's attention was the long gray probe that was only 20 feet distant and directly in

front of his window. The probe, one of three such devices connected to the main object, appeared solid and about 10 feet in length.

Bob yelled for Sue, cleaning up the kitchen. She looked out the window and screamed, "Oh my God what is it?", then the couple continued to watch the hovering object for several more minutes. Sue became frightened and Bob told her to call his brother and wife who lived near Greensburg so they could have other witnesses.

It would take the other couple at least 10 minutes to get to Bob's house. In the meantime, Bob continued to watch the object from the window. It was about 50 to 60 feet in diameter and no more than 30 feet above the pond. The oval object was of a dark battleship gray color with a dome-shaped top. It gave Bob the impression "that it was old or ancient." The bottom of the object was hollow and according to the witness "it was like looking into an open shaft." There were lights inside the open bottom that spun so fast you could not tell what direction they were moving. This opening was about 20 feet in diameter.

### FIGURE

There was a white light emitting from this section which illuminated the area around the craft, giving Bob the opportunity to observe the detail. The entire object was the same color. About  $\frac{3}{4}$ s of the way up the craft, there was a catwalk that was evenly centered. And standing on the catwalk was a single human-like figure with its hands up to its eyes, looking directly at Bob.

Behind the figure were portholes and an opening from which red, green, blue, white and orange lights could be seen flashing at times. What looked like instrument panels were seen and at times shadows would move across these apertures as if people were moving around inside.

As Bob watched, another similar figure came onto the catwalk and began communicating with the other being. At this point Bob began looking for his clothes in the dark room, and when finally dressed went out on the porch and continued to watch the object which was now beginning to move very

(continued on page 17)

## SIGHTINGS

A Western Air Lines Pilot and former Naval Aviator (Lt.) has shared two sighting experiences with MUFON which are considered interesting, but not of a significant classification. The credibility of the witness adds stature to the report. His responses to the six points describing the incident on the MUFON UFO Sighting Questionnaire (Form 1) is quoted as the source for this short article. (The pilot's name is in the MUFON file.)

### FIRST SIGHTING

"In November or December of 1984, I was 'deadheading' in First Class from San Jose, California to Salt Lake City to pick up a Western Air Lines flight in which I was to be the First Officer on a Boeing 737. During the approach to Salt Lake International Airport (Utah), I happened to be looking to the right side as the Boeing 727 was making its approach to Runway number 34L (landing north). I had been observing the different cloud formations when I noticed that the clouds were beginning to glow red or acquiring a reddish tint at one point in the cloud base. (Weather conditions at the time consisted of cloud layers with an overcast just obscuring the mountain tops just east of Salt Lake City.) The time was 5:30 p.m. M.S.T.

"At first I thought that it was a possible reflection from the distant city lights of Salt Lake City. As I continued to watch the cloud base at that point, I noted that the clouds were becoming more red. Suddenly, a red point of light or a small sphere of light emerged from the cloud base in a vertical descent near the mountains. Continuing its vertical descent, the light "dimmed-out" as it approached the ground as if it decided to switch off its external light. The red light did not go out instantaneously, but dimmed gradually. It appeared to be near the foothills of the mountains when last observed and might possibly

have been landing. The lighting conditions at this time was Dusk, since the Sun had just set.

"I do not believe that this was a conventional aircraft of any kind. A helicopter does not normally take vertical descents into mountainous areas through cloud layers and an overcast. The object behaved unlike anything that I have ever witnessed. I made a mental note of what I had witnessed and then put it out of my mind for a while. The duration of the sighting was 10 seconds."

### SECOND SIGHTING

His second possible UFO sighting occurred at 7:45 p.m. P.D.S.T. on July 4, 1985, in San Jose, California with his wife as the second witness. "My wife and I had gone for a drive in the southeast area of downtown San Jose. We were sitting at a stoplight at the corner of Capitol Expressway and Senator Road. My wife called my attention to an object in the sky that she noticed hovering in a stationary position. The object was estimated to be about 4 miles southeast of our position and low on the horizon.

"It was early evening with the sun to our backs and clear sky conditions. As my attention focused on the object, it began to move and shortly thereafter began a steep climb of about 10 - 20 degrees of inclination to the southwest of its original position. Momentarily, it reversed course and descended. It then went into a rapid horizontal zig-zag motion, which could not be accomplished by any aircraft or helicopter that I am aware of. The latter action convinced me it was a probable UFO.

"Just after the object started the zig-zag motion, the stop light turned green and unfortunately I had to move along in the north bound direction on Capitol Expressway. By the time that I could get turned around, the object was

gone. The duration of the sighting was 20 to 30 seconds. A sketch on the report form depicts a black disc-shaped object with blunt ends and no apparent lights. He estimated the distance as 4 to 6 miles with the lowest altitude 1000 feet or less. The apparent size was one-twentieth of the full moon."

---

### NEW HAMPSHIRE CLOSE ENCOUNTER

Oct. 15, 1984, Time: 8:42 PM. An anonymous call was received at the Keene, NH Police Department. A man from Winchester, NH, a small town south of Keene, called to report strange looking lights hovering over the city. He refused to give his name, stating his wife would think he was crazy.

Sgt. Jack Zeller was dispatched to Route 12 to investigate. It was a clear night in the southern New Hampshire city. Sgt. Zeller did not hurry to the scene because he felt whatever it was would be easily explained or gone by the time he arrived. As he proceeded south on Route 12 toward Route 9, a car coming in his direction skidded to a stop. A man jumped out pointing to the west. Sgt. Zeller stopped his cruiser; he didn't expect to see anything so soon.

What he saw was "obviously unconventional." As a trained observer he was able to describe what was seen easily — a number of pulsating lights, red, white, and green, absolutely motionless in the sky at an altitude of 800 to 1000 feet. He estimated the distance at about one eighth of a mile.

At this point Zeller called back to headquarters using the car radio. He remained in radio contact throughout the sighting. By now more cars had stopped and more people were observing the show. One of the observers suggested to Sgt. Zeller that

(continued on page 17)

Dull Metallic  
Cream Color

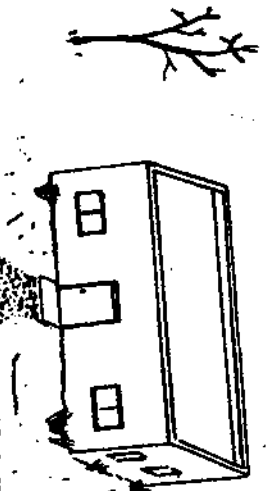

P. GERMAN  
1985

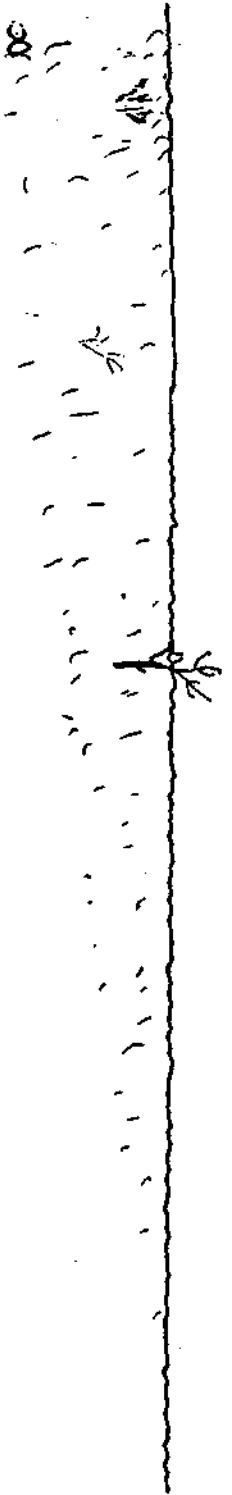



# RICHARD HAINES: AN INTERVIEW

By Dennis Stacy

*Richard F. Haines, in the tradition of Hynek, McCampbell, Friedman, McDonald, Vallee, et al, is one of a handful of scientists who manages to juggle a career in his field of expertise with writings and studies of the UFO phenomenon.*

*Haines is a research scientist in Life Sciences at NASA's Ames Research Center, Moffett Field, California. His Ph.D. from Michigan State University is in the area of experimental psychology/physiology. He is the author of numerous scientific articles as well as Observing UFOs (1978), and also edited UFO Phenomena and the Behavioral Scientist (1979).*

**Stacy:** Dr. Haines, you've let it be known that you are compiling case histories of UFOs sighted from aircraft. Why did you decide to concentrate in this one specific area?

**Haines:** Several reasons were involved, of course, one of them being that pilots represent a very stable personality type with a high degree of training, motivation, and selection. When they say they have seen something, you know they have seen something. They have a professional reputation at stake, so you also know that when they do come forward and make a report, they have done a pretty good job, by and large, of analyzing in their own mind what it might be and of eliminating a number of explanations already.

Another reason would be they have available to them a lot of electromagnetic sensors of various kinds on board the aircraft itself, which can possibly record some manifestations of the phenomenon, such as electromagnetic frequency and energy content. Another reason is that pilots can control the location of their plane so that they can maneuver to gain the best vantage point, under some conditions. If you're flying a commercial



Dr. Richard F. Haines

Dennis Stacy

plane, that might not be so easy, but a military jet, for instance, might climb above the phenomenon so that it's seen against the ground as a background. By doing that, you can place some kind of maximum range between you and the object, and if you can determine its apparent angle, then you can form a good idea of its size, at least its maximum size.

**Stacy:** How did you initially go about gathering reports?

**Haines:** Initially I was intrigued more than anything else because the literature contains so many good pilot cases. So I went through the files of Project Blue Book on microfilm next and noticed that the quality of those sightings was generally much higher than that of the ground sightings. It also struck me from a historical point of view that no one had done very much with the pilot cases and that's basically how I got started, many years ago.

In my work, I also deal with a lot of pilots, and one of the routine questions I ask them, is have you ever seen anything you couldn't explain? That got me out of a historical into a more present perspective, and now I have literally contacts all over the Free World with aviation officials who will send me information on a confidential basis.

**Stacy:** Is there any reluctance on the part of the pilots themselves to discuss their sightings?

**Haines:** Sure, there is, which I think is only natural. They have a job at stake. There might be a company policy against it, any number of reasons why you might have to be very careful.

Ask yourself why you don't see more UFO articles in all these free magazines in the back of the airplane seat in front of you? The reason I think

(continued next page)

## HAINES, continued

is fairly obvious: airline companies don't want their passengers to know that over 3000 pilots have seen these things, even though they're a popular subject. The negative consequences are just too great.

**Stacy:** You mentioned that you came into contact with pilots in the course of your work. Could you tell us a bit more about what that entails exactly?

**Haines:** I'm a research scientist at the Ames Research Center, working in the area of human vision and optics, the way the eye and the brain work together. Technically, the field is known as Aviation Human Factors. We're doing research right now into what information is essential for pilots to land a plane in bad weather, information that is going past them out the side windows, not coming head-on, their peripheral vision. I'm currently heading up a research group focusing on that aspect. The output of that, which is laboratory research, would hopefully be the improvement of cockpit window design, so that Boeing, Lockheed, Douglas and other airplane manufacturers could take into account what the pilot brings into the cockpit, which is his own visual capabilities. They haven't done that by and large. The design process has so many other factors which push the design in one direction that it has received relatively little input from the behavioral sciences.

**Stacy:** Have you been able to formulate the characteristics of a typical aerial sighting as opposed to a ground sighting? Is there any major difference in the two?

**Haines:** No, there are no major differences. I'm convinced now, after a lot of research, that the same phenomenon is being seen by the pilot as the ground observer. To me, that's an important breakthrough, because it's often said that only crazy people see UFOs. If we can show that a highly stable, mature, responsible group of witnesses is seeing them, then ipso facto, the ground witnesses, as flaky as some of them might be, are also seeing the same phenomenon.

**Stacy:** What might be the typical characteristics of an aerial UFO sighting?



HAINES IN PASADENA

— Dennis Stacy

**Haines:** In that respect, I think there are probably more differences than there are similarities, and by that I mean that every case is different. The large issue is what commonalities exist among the cases that refer to the object itself? The flight dynamics, for instance, are probably as diverse and different as the number of sightings.

There are categories, though, and I can tell you about them because I'm writing a book on the subject. First, let's separate the subject into night cases and day cases. Seventy per cent of the aerial sightings occur during the night, 30 per cent occur during the day. Of the nighttime sightings, almost all of them are tiny point-sources of light, like stars, perhaps a single light or a number of them in different patterns.

The daytime cases, on the other hand, are almost always angularly large, disc forms, with some sort of silvery, or aluminum-appearing structure or surface. The nighttime sightings, almost by definition, have to be emitting light, giving off light. The daytime sightings, again almost by definition, have to be reflecting natural light. That's not necessarily or absolutely true, but it's more true than not.

Now as regards to flight dynamics,

one pattern or category that comes out of the 3000 cases is what might be called the head-on approach. Then at the last moment it swerves and avoids contact with the airplane. Those are very interesting because the approach is so fast, even in a light plane, that visual perception doesn't really have time to come into full play and you impute a shape to the object. You say it was a UFO when it may have been just another Cessna, let's say. In many cases like that, though, there is a sub-category in which the object doesn't just speed by, but comes back and hovers off the wing.

**Stacy:** Wouldn't an incident like that indicate that the UFO, or object, was showing a distinct interest in the terrestrial aircraft?

**Haines:** Well, there is another category in which an object will approach a plane, hover nearby, circle it, say, and then stay off one wing-tip awhile; maybe flip over and then hover off the other wing-tip. All I can say is that to the degree that evidence is true, the airplane is the focus of attention. If I were to use words like curiosity and interest, I would be making a lot of assumptions and that's

(continued next page)

## HAINES, Continued

not something I would like to do. Those words are a little bit too "human." I don't know what their motives are, if there is a "they."

What if this is an ionization effect? Every engine, whether it's propeller or jet, puts out an ionization trail. If the object happens to be ball-lightning, which is possible, then perhaps it follows in that ionization trail. That might even explain a head-on approach, if another airplane had gone by earlier. I don't think it would explain the wing-tip or circling effect, though.

**Stacy:** Have you had difficulties approaching military pilots?

**Haines:** More difficulty than not, perhaps. For one thing there is a real hesitancy to tell people stories until you get to know one another. In other words, you have to develop a rapport and as a trained psychologist I've been helped somewhat because I will never come out and ask a direct question which would turn them off. You have to build up to it. You have to establish your own credibility and motives. You have to be transparent, because if they think you're hiding something, forget it! You're probably not going to get any decent data: they'll just make something up to get rid of you.

So, I've tended to take the long term approach of getting to know the person. Too, where I work helps. They know I'm not a kook and that I've got a reputation at stake just like they have. When he knows that and when he knows that I'm going to keep the conversation confidential, then little by little, the barriers begin to come down. Then a certain cascade effect begins to work and the story eventually comes out.

**Stacy:** Has any other sort of data besides the pilot's subjective account become available? I'm thinking of gun camera film, for example.

**Haines:** I don't have access to security information and it's my understanding that anything like that would be classified. I will say this, though, that the files of Project Blue Book, which ended in 1969, are absolutely replete with that kind of information, but you can't get at it. It's not there anymore.

**Stacy:** As far as you know, has a flight-



—Dennis Stacy

recorder ever turned up with information that would pertain to a UFO?

**Haines:** No, not really that I know of. See, the flight recorder is an endless tape. Every half hour it repeats itself. In the event of a crash, there are switches which turn it off so that you get the last half-hour of flight. To my knowledge, there has never been a case in which an effort was made to directly extract a flight-recorder after a UFO sighting was made.

See, flight-recorders are required by law aboard commercial aircraft and the airline companies are there to make money. They don't take a lot of time trailing after UFOs because it's so incidental to what they're doing. I think they would just rather dismiss it and concentrate on turning a profit.

**Stacy:** So, as far as you know, then, a UFO has never been involved in the last thirty minutes of flight of a commercial airliner?

**Haines:** No.

**Stacy:** Have you ever asked the individual pilots or aircraft about their subjective feelings about whatever it was they saw? Whether they were frightened or whatever?

**Haines:** Oh, yeah, that's a common question I ask and I get a small range of answers. That's a good question, though, that's interesting. The common answer I get is curious, because it isn't intuitive. I have many pilots tell me that during the encounter, when they're being approached or hovered nearby by some strange object, that they had a sense of peace and calm spread over them as if nothing was going to happen, everything's under control, don't worry. Then that feeling goes away when the phenomenon goes away.

**Stacy:** And then they become scared?

**Haines:** Oh, it depends on the situation. If the engines stopped, then they become scared, yes.

**Stacy:** Do the engines usually start

(continued next page)



—Dennis Stacy

## HAINES, Continued

back up?

**Haines:** In most cases, yes. I only know of one case in which the engine didn't start back up. The crew bailed out and then the plane crashed. That was a military flight.

**Stacy:** Does the phenomenon effect propeller and jet engines differently, or in any kind of particular pattern?

**Haines:** There aren't that many cases involving actual engine failure and, of course, the operation principles are very different of the two. But that's one of the things we're really interested in, is finding cases that would be diagnostic, that would help us understand the nature of the radiation that is transmitted, if you like, or whatever fields are surrounding the phenomenon.

In medical diagnosis of the human body, the doctor goes after patterns of symptoms. He hopes to find a range of symptoms that properly analyzed will diagnose the core problem. I'm trying to use the same approach, that in the electromagnetic domain we might find an array of frequencies, energies, different sensors operating in different ways, that can only operate the way they do because of a certain kind of radiation source — pulsed microwave,

for instance, or plasma physics, high magnetic toroidal fields, or a number of other possibilities.

That, to me, is the interesting dimension of the UFO phenomenon, and why I spend any time on it at all. I'm not interested in just the psychological or physical dimension.

**Stacy:** Does your evidence indicate to you that the phenomenon is either natural or mechanical?

**Haines:** No, I'm not willing to go that far yet.

**Stacy:** But the possibility exists that it could be a plasma effect or some other entirely natural phenomena?

**Haines:** Sure, it could be. I will say this. I think the phenomenon definitely represents an extremely high energy density. I mean high power levels, packed within small volumes. Beyond that, I'm just not ready to say anything. Ask me again in ten years (Laughs).

**Stacy:** You don't see anything in the patterns of behaviour of the phenomenon that would indicate an answer one way or the other as to whether we're dealing with something artificial or organic?

**Haines:** Well, why is there a large peak in aircraft sightings around nine to eleven p.m.? Why is that?

**Stacy:** Because there are more

airplanes flying then?

**Haines:** No, that's not the answer. See, the thing about these patterns of behaviour may or may not be diagnostic. We may be dealing with a phenomenon that is purposely deceptive, that is giving us views of itself that are not true. It's called deception strategy and the military does it all the time. It's an art of war and of government intelligence agencies.

For all we know, we've been fed a line of deceptions from the very beginning under a longterm master plan, if you will, to lead us into a totally erroneous view of what the phenomenon is. That's pretty far out, I admit, for a nuts'n'bolts person like me, which I tend to be. But I have to take it seriously. I have to entertain the possibility, so I don't take everything at face value. I have to consider as many as possibilities as there are.

This phenomenon, whatever it is, is one of the last frontiers. I think outer space is a frontier, I think the human brain is a frontier, and I think the UFO phenomenon is a frontier.

**Stacy:** And might there be a connection between all three?

**Haines:** You said that. I'll say it's an interesting study.

**Stacy:** Dr. Haines, we thank you.

— MUFON —

AMATEUR  
RADIO  
NET

---

EVERY SATURDAY  
MORNING  
AT 0800 EST (OR DST)  
ON 7237 KHz S.S.B.

**MUFON**

103 OLDTOWNE RD.  
SEGUIN, TX 78155

## LIFTING, Continued

answer, but in some cases the displacement appears to be a purposeful act on the part of the UFO operator.

From the mass of evidence collected on these types of cases, McCampbell has managed to distill several reoccurring facts. From his book, *Ufology*, we find the following observations:

1. "It is abundantly clear that a strange, hitherto unrecognized force prevails within a cylindrical zone having the same diameter as the UFO and extending from it to the ground."

2. "The force acts vertically upward upon various objects, imparting to them a rotation."

3. "As no stones or dry sticks seem to have been affected, the force apparently couples selectively to objects, presumably on the basis of their composition."

It's puzzling that UFOs exert an upward force when normal experience would seem to indicate a downward thrust that would be required to keep their craft in the air. It is possible the upward force the UFOs exert is separate from the UFOs propulsion system. Unfortunately, one can only speculate until we have in our possession a functional UFO craft. But for witnesses like Catherine Burk, the ability of UFOs to levitate a motor vehicle is more than mere speculation.

## WEEK, Continued

next August. Let us begin now to ensure that we are even better prepared, better informed, and better organized to offer public information during our second National UFO Information Week.

**SUPPORT  
UFO  
RESEARCH**

MUFON sponsors an annual symposium on UFO research and investigation, typically held in major metropolitan areas each year. Speakers include PhD scientists and others knowledgeable about UFO-related topics. This Index compiles authors names, titles, and subjects discussed. Additional information on availability of Symposium *Proceedings* or article reprints is available from the above address.

## AUTHOR INDEX

- ADAMS, Thomas R. "Animal Mutilations: A Decade of Mystery" 84:45-63  
ALZOFON, Frederick E. "UFO Propulsion Model" 82:42-48  
ANDRUS, Walter H., Jr. "Cattle Mutilations That Defy Conventional Explanations" 83:112-117  
BEARDEN, Thomas E. "Hyperspace (Virtual State) Engineering" 80:104-120  
BRAY, Arthur. "Professionalism in UFOlogy" 82:14-24  
CERNY, Paul C. "Continuing UFO Deception and Confusion Syndrome" 83:170-181  
CHRISTENSEN, Marge. "Public Information: Top Priority for UFOlogists" 84:14-22  
CLAMAR, Aphrodite. "Missing Time: A Psychologist Examines the UFO Evidence" 81:76-78  
DOWNING, Barry H. "Faith, Theory and UFOs" 81:35-42  
DRUFFEL, Ann. "Southern California's Straight Line Mystery in UFO Sightings" 83:61-81  
EVANS, Hilary. "Entity Enigma" 84:79-90  
FRIEDMAN, Stanton T. "Flying Saucer Technology" 80:139-149  
\_\_\_\_\_ (w/W.L. Moore). "Roswell Incident: Beginning of the Cosmic Watergate" 81:132-153  
GERSTEN, Peter A. "What the Government Would Know About UFOs If They Read Their Own Documents" 81:21-33  
GREENWOOD, Barry J. "UFO Secrecy 84: Big Brother is Watching Them" 84:92-107  
HAINES, Richard F. "Review of Selected Aerial Phenomenon Sightings from Aircraft from 1942 to 1952" 83:14-44  
HAISELL, David. "UFO Research: An International Perspective" 82:66-78  
HIND, Cynthia. "African Encounters: Case Investigations" 81:80-91  
\_\_\_\_\_ "Tribal Reactions to UFOs in Africa" 84:65-77  
HOLT, Alan C. "UFO Propulsion: Pulsed Radiation and Crystalline Structure" 83:128-168  
\_\_\_\_\_ "UFO Light Beams: Space-Time Projections" 84:121-138  
HOPKINS, Budd. "UFO Abductions: The Invisible Epidemic" 81:44-58  
\_\_\_\_\_ "Haunting of Kitley Woods: An Ongoing UFO Saga" 84:168-184  
HYNEK, J. Allen. "UFOlogy as a Profession: A Manifesto" 81:14-19  
\_\_\_\_\_ "Planning for the Next UFO Flap" 82:80-83  
\_\_\_\_\_ "Case Against E.T." 83:119-126  
\_\_\_\_\_ "Properties of the UFO Phenomenon" 84:163-166  
IMBROGNO, Phillip J. "Boomerang Mystery" 84:140-161  
JORDAN, Peter A. "Cattle Mutilations and the Imagined Culprits: A Psychological Perspective" 83:102-111  
KISSINGER, L. David (w/J.F. Schuessler). "Project VISIT: An Approach to Determine 'What Are They?'" 80:14-19  
McCAMPBELL, James M. "UFO Interference With Vehicles and Self-Starting Engines" 83:46-59  
MERRITT, Fred. "UFOCAT and a Friend with Two New Ideas" 80:31-52  
MONTIETH, Henry C. "Unified Field Theory and the UFO" 80:77-101  
MOORE, William L. (w/S.T. Friedman). "Roswell Incident: Beginning of the Cosmic Watergate" 81:132-153  
\_\_\_\_\_ "Roswell Investigation: New Evidence in the Search for a Crashed UFO" 82: 85-104  
\_\_\_\_\_ "UFOs: Uncovering the Ultimate Answer" 83:83-100  
NIEMTZOW, Richard C. "Preliminary Analysis of Medical Injuries as a Result of UFO Close Encounters" 80:131-137  
NORMAN, Paul B. "Countdown to Reality" (UFOs in Australia). 84:24-43

- OBERG, James E. "Quality Control of the UFO Data Base: Some Suggested Techniques" 80:122-129
- OWEN, George & Iris. "UFO Phenomenon and its Relationship to Parapsychological Research" 82:26-32
- PERSINGER, Michael A. "Predicting UFO Events and Experiences" 82:34-40
- PHILLIPS, Ted R. "Close Encounters of the Second Kind: Physical Traces" 81:93-129
- SCHUESSLER, John F. (w/L.D. Kissinger). "Project VISIT: An Approach to Determine 'What Are They?' " 80:14-29
- \_\_\_\_\_ "Radiation Sickness Caused by UFOs" 82:50-64
- \_\_\_\_\_ "Cash-Landrum Case: Speculation About the Medical Effects" 84:109-119
- SPRINKLE, R. Leo. "UFO Contactees: Captive Collaborators or Cosmic Citizens?" 80:54-75
- STANFORD, Ray. "Instrumented Sensing, Recording, and Documentation of Transient Phenomena in UFO Events" 80:151-177
- WESTRUM, Ronald M. "Human Factors in UFO Sightings" 81:60-74

—Compiled by Richard H. Hall

## CE, Continued

slowly and ascending just a little higher. The two figures were now gone.

At this time the other couple pulled in the driveway, and they all jumped into the car and followed the object as it began to move over a hill, still only about 50 feet off the ground. Bob's brother, who was driving while trying to watch the object, got the car stuck on the slick road and they all got out to watch the hovering craft which was now directly above them.

A brilliant light was emitted from the bottom of the craft, obscuring the shape of the object. It remained completely silent, as it had during the entire encounter. The light suddenly began to accelerate vertically into the sky until it looked like one of the other stars. It then changed to a brilliant red color, moving straight across the sky and out of sight.

The entire episode lasted nearly 20 minutes. Two witnesses observed the object at a distance of no more than 30 feet and two additional observers came to the scene and verified the observation.

## DISBELIEF

This UFO encounter had a drastic affect on Bob's life since he was a profound disbeliever in UFO reports prior to this experience. A number of years before his sighting, Bob and his younger brother who witnessed this

event were discussing UFO reports that had been on the evening news and they nearly ended up in a fist fight since Bob suggested that only crazy people saw those things.

For 5 years Bob had been in the Navy, and was in fact a hangar deck aircraft director on one of our country's largest aircraft carriers and was quite familiar with military aircraft. As Bob told me, "If I hadn't seen it for myself, I could not have been convinced."

Bob took a lot of ridicule after telling various relatives and friends about his encounter. He no longer worries about that. He knows what he saw and is now convinced UFO's are real.

## NEW HAMPSHIRE, Continued

he shine the cruiser spotlight at the object. The spotlight used was 200,000 candle power. "I was right on aim," but it didn't light the object. (I feel Zeller's estimate of one eighth of a mile was incorrect. The spotlight should have reached it at that distance.)

As soon as the light was on aim the object began to move toward the cruiser. It lowered altitude as it came closer. The object leveled off at a height of 100 feet, not far from the observers. As it continued to get closer one of the bystanders asked Sgt. Zeller to get his shotgun. Zeller responded with "No, I think we'll ride this one out."

The object passed directly over the

cruiser at a speed of 10 to 15 miles per hour. "I had it lit up like daylight," Zeller stated.

He described the object as having a dull metallic off-white or cream color. It was 10 to 15 feet wide and 45 to 50 feet long. The belly had longitudinal planes from front to back like the hull of a boat. He saw no landing gear, no windows, no seams, no doors, no obvious source of power, and it made no sound except for a two-toned hum for a second or two as it passed directly overhead.

The police sergeant also stated he may have seen short stubby wings, but he is not sure if he saw them or someone mentioned them. The object continued its straight flight path over the cruiser, across the street and then stopped over a car wash. It turned around as if to come back to the cruiser, hovered a few seconds, then instantly moved sideways to hover over the Ramada Inn at the junction of Route 9 and Route 10. It hovered again for a few seconds, then moved to the south-east at a leisurely pace. It then sped off into space and was out of sight in a second or two.

The initial interview with Sgt. Zeller and the audio tape recording of that interview was conducted by Mr. William J. Chapleau, MUFON State Director for Vermont.

—By Peter Geremia

## MESSAGE, Continued

\* \* \*

The MUFON Metroplex UFO group in the Dallas-Fort Worth area has been meeting monthly with outstanding dinner speakers under the leadership of **Ron and Catherine (Kay) West**, President and Vice President respectively. On September 14th, **Dr. Leo Sprinkle** was the speaker, followed by **John F. Schuessler** on October 12th. The November monthly meeting will be devoted to Field Investigator training. On December 7, 1985, **Travis Walton** will relate his experiences. For more information on the location of each meeting contact Kay West at (214) 696-4257.



## MESSAGE, continued

alphabetically by states, therefore some of our members have already received their exam and the remainder will follow as our Seguin office provides current address lists. Each State Director will also receive a current copy of the names, addresses and telephone numbers of every member within their state.

The MUFON 1985 UFO Symposium Proceedings with the theme "UFO: The Burden of Proof" are available from MUFON in Seguin, Texas for \$10.00 plus \$1.50 for postage and handling. All foreign members should use an international postal money order for payment in U.S. funds.

\* \* \*

Our prayers and best wishes for recovery are extended to Dr. **J. Allen Hynek** after his recent operation in St. Louis, Missouri, followed by a brief confinement at the University of California Medical Center in San Francisco for extensive tests. He has now returned to his home in Scottsdale, Arizona to recuperate.

\* \* \*

For several years, **Robert Gribble**, who operates the National UFO Reporting Center in Seattle, Washington, has sent MUFON an individual report form of current UFO sightings with the pertinent details so an on-the-site in-depth investigation could be conducted by MUFON Field Investigators. Bob discontinued this valuable procedure at the end of December 1984 and is now submitting a summarized report to **Michael Hart** for the Compufon computer network. Obviously, we have lost a very important source of raw UFO sightings that clamor for investigation. I have appealed to Mr. Gribble to reinstate his original procedure, since his UFO telephone hotline number 1-206-722-3000 has the most extensive coverage throughout police agencies and airports in the U.S.A. We hope that Bob will recognize that his fine service is handicapped by not utilizing the services of the largest UFO investigative team in the U.S.A. — the Mutual UFO Network.

(continued on page 17)

# THE NIGHT SKY

November 1985

## Bright Planets (Evening Sky):

Jupiter is now the only evening planet. It is due south at dusk and sets in the WSW about 9:45 PM in midmonth.

## Bright Planets (Morning Sky):

Venus is getting difficult to see in the eastern sky, rising only about 1¼ hours before sunrise in midmonth. Meanwhile its much fainter reddish neighbor Mars, in Virgo, is well up in the SE before the sun rises.

## Meteor Showers:

A bright gibbous moon interferes all night during the Taurids peak on November 3. The slow reddish meteors normally reach about 15 per hour before dawn. On the other hand, the swiftest of all shower meteors, the bluish Leonids, achieve maximum (15 per hour) under dark skies on the 17th.

## Halley's Comet:

This famous celestial visitor has left Orion and during November races across Taurus and Aries, entering Pisces near the end of the month. Early this fall Halley was somewhat fainter than expected. If it gets back "on track" and attains 7th or 8th magnitude by mid-November, it would then be visible through binoculars as a tailless smudge of light. The comet passes north of the V-shaped Hyades from Nov. 10-12 and south of the Pleiades on the 16th and 17th. By the 18th Halley becomes accessible all night, rising in the NE at sunset and setting in the NW at sunrise. It passes within 58 million miles of the earth on the 26th enroute to the sun; a somewhat closer second approach to earth occurs on the comet's outbound leg next April. Once again best viewing is around the middle of the month when the moon is out of the way. On the 15th Comet Halley's position is at R.A. 3h 49m, Dec. +21°47' (1950); this places it in the same binocular field as the Pleiades—a beautiful sight!

## Moon Phases:

Last quarter--Nov. 5  
New moon--Nov. 12  
First quarter--Nov. 19  
Full moon--Nov. 27

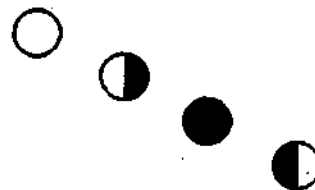

## The Stars:

The bright constellations of winter--Orion the Hunter, Taurus the Bull, Auriga the Charioteer, Gemini the Twins--are already appearing above the eastern horizon at 9 PM in midmonth. The dim stars of autumn, including the Great Square of Pegasus, occupy the central and southern sky, and the Summer Triangle prepares to exit the celestial scene in the west.

In midevening look for a faint patch of light almost squarely overhead in Andromeda the Princess. You are glimpsing our sister spiral galaxy in space, the Great Andromeda Spiral, the most remote object detectable with the naked eye. This immense gathering of billions of stars appears not as it is today but as it was two billion years ago. It required that much time for its light to cross space and reach our eyes. And this is a nearby galaxy!

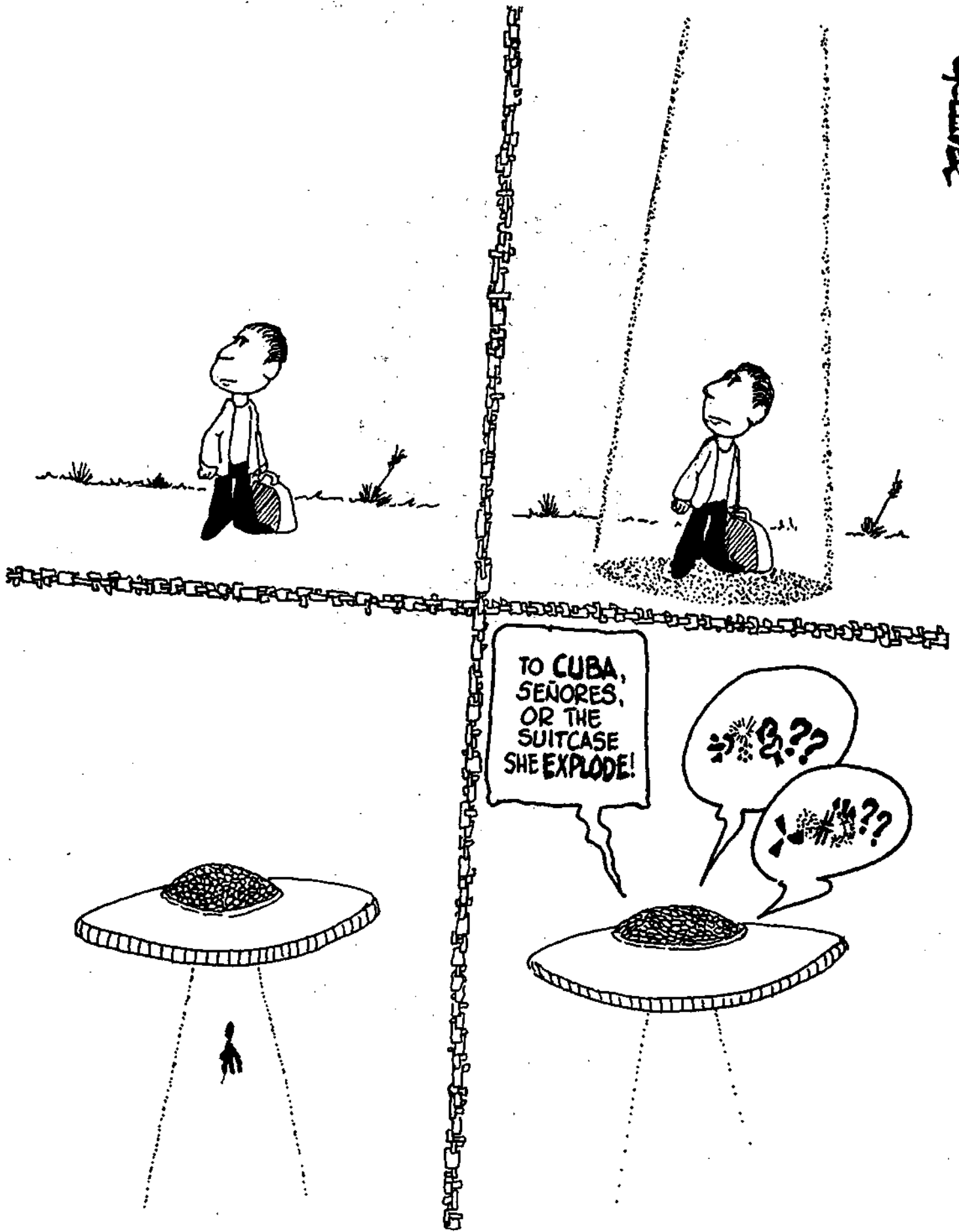

# DIRECTOR'S MESSAGE

by  
Walt Andrus

We are happy to report that the first "National UFO Information Week" on August 18-25, 1985 exceeded all of our expectations in the states participating. **Marge Christensen** has submitted an article for the Journal with photographs depicting a few of the highlights. It was a very good example of cooperation between CUFOS, the Fund for UFO Research, and MUFON. Plans are already underway for the 1986 program.

\* \* \*

A committee organized during the UFO Forum in Beverly, Massachusetts has submitted proposed plans for greater cooperation between CUFOS, FUFOR, and MUFON, whereby each will have basic responsibilities thus reducing duplication of effort and ensuring maximum utilization of our resources. The three major UFO research organizations have unique resources and assets to offer to the field of UFOlogy. By capitalizing upon these unique assets, we should be able to significantly advance serious research into the UFO phenomenon as well as to make further progress toward eradicating the popularly held notion of the UFO subject being "pseudoscience" practiced by mere hobbyists.

\* \* \*

For the past two years Mrs. Marge Christensen has been serving in a dual role as the State Director for Massachusetts and nationally as MUFON's Public Relations Director. The latter has become virtually a full-time job considering the many activities that Mrs. Christensen has implemented. Upon the submission of her resignation as State Director for Massachusetts, the Massachusetts MUFON Board of Directors recommend **James R. Melescius**, presently the State Section Director for Norfolk County, to fill this post.

**Forrest R. Lundberg** has recommended the following MUFON reorganization for the state of Iowa: **Donald A. Curtis** has been elevated



Marge Christensen

from Assistant State Director to State Director for Iowa, replacing Mr. Lundberg who has accepted the position of State Section Director for Polk and Warren Counties.

**Leonard Sturm**, State Director for Illinois, has appointed **Robert Matheny** as the State Section Director for Edgar County. Mr. Matheny has a B.A. in sociology and social work. **Hal Starr** of Phoenix, Arizona has been approved as the new State Section Director for Maricopa County. Mr. Starr is best known for the longest continuous daily UFO radio show in the world, starting in 1947 and heard in 7 English speaking countries. **Donald M. Ware**, State Director for Florida, has announced the appointment of **Duane E. Pike** of Tampa to become the State Section Director for Hillsborough, Pinellas, and Polk Counties. Mr. Pike, a former MUFON member in 1979 to 1981, was a Captain in the U.S. Army in artillery and military intelligence.

\* \* \*

H.B.O.'s "America Undercover"

cable television show titled "UFOs: What's Going On?" produced by Robert Guenette Productions and directed by Fred Rosen ran ten different times as a special, starting September 10th and ending on September 29th. The film was very well done and provided favorable public education on UFOs. A major complaint was their failure to give credits to the many people who contributed their time and effort as consultants, provided cases, photographs, motion picture film, etc. However, they gave prominent credits to every person employed by Robert Guenette Productions who had any association with the film. Without the valuable contributions of a number of prominent UFOlogists in North America, the film could not have been made.

\* \* \*

**Dan Wright** and his host committee have announced that the following speakers have been confirmed to speak at the MUFON 1986 UFO Symposium on June 27, 28 and 29, 1986 at Michigan State University in Lansing: **Michael D. Swords, Ph.D.**, **John F. Schuessler, M.S.**, **David M. Jacobs, Ph.D.**, **Bruce S. Maccabee, Ph.D.** and **Robert H. Bletchman, J.D.**

Due to the success of the Massachusetts MUFON UFO FORUM this year, where close to 300 people attended from 16 States and Canada, the weekend of August 9 and 10, 1986 has been reserved at the Beverly Golf Club for the 1986 UFO Forum.

\* \* \*

In order that MUFON may upgrade the professional investigative stature of our Field Investigators, State Section Directors, State Directors and Research Specialist, the new Field Investigator's Examination is being administered by Dan Wright and his committee in Michigan. It will be done

(continued on page 18)

# MUFON UFO JOURNAL

NUMBER 211

NOVEMBER 1985

Founded 1967

OFFICIAL PUBLICATION OF



MUTUAL UFO NETWORK, INC.

\$1.50



## MUFON UFO JOURNAL

(USPS 002-970)

(ISSN 0270-6822)

103 Oldtowne Rd.

Seguin, Texas 78155-4099

**DENNIS W. STACY**  
Editor

**WALTER H. ANDRUS, JR.**  
International Director and  
Associate Editor

**THOMAS P. DEULEY**  
Art Director

**MILDRED BIESELE**  
Contributing Editor

**ANN DRUFFEL**  
Contributing Editor

**TED BLOECHER**  
**DAVE WEBB**  
Co-Chairmen,  
Humanoid Study Group

**PAUL CERNY**  
Promotion/Publicity

**MARGE CHRISTENSEN**  
Public Relations

**REV. BARRY DOWNING**  
Religion and UFOs

**LUCIUS FARISH**  
Books/Periodicals/History

**ROSETTA HOLMES**  
Promotion/Publicity

**T. SCOTT CRAIN**  
**GREG LONG**  
Staff Writer

**JAMES LEMING**  
**SIMONE MENDEZ**  
Staff Artists

**TED PHILLIPS**  
Landing Trace Cases

**JOHN F. SCHUESSLER**  
Medical Cases

**LEONARD STRINGFIELD**  
UFO Crash/Retrieval

**WALTER N. WEBB**  
Astronomy

**NORMA E. SHORT**  
**DWIGHT CONNELLY**

**DENNIS HAUCK**  
**RICHARD H. HALL**  
**ROBERT V. PRATT**

Editor/Publishers Emeritus

The MUFON UFO JOURNAL is published by the Mutual UFO Network, Inc., Seguin, Texas. Membership/Subscription rates: \$15.00 per year in the U.S.A.; \$16.00 foreign in U.S. funds. Copyright 1985 by the Mutual UFO Network. Second class postage paid at Seguin, Texas. POSTMASTER: Send form 3579 to advise change of address to The MUFON UFO JOURNAL, 103 Oldtowne Rd., Seguin, Texas 78155.

# FROM THE EDITOR

Inside we think you'll find another informative issue of the Journal including Cynthia Hind's report on an African summer sighting, a couple of recent cases from Florida, and Walter Webb's coverage of the Massachusetts MUFON Forum, as well as our regular departments.

In the meantime, the editor and staff of the Journal wish you and yours the safest and happiest of holidays. Until the next time.

## In this issue

AFRICAN REPORT, by Cynthia Hind .....	3
FLORIDA FLURRY, by Donald M. Ware .....	6
MASSACHUSETTS FORUM, by Walter N. Webb .....	8
THE MEIER CASE, by James W. Deardorff .....	11
RANDLES REPLIES, by Jenny Randles .....	12
NEWS 'N' VIEWS .....	13
UFO SECRECY, by Larry Bryant .....	14
PROCEEDINGS INDEX BY SUBJECT, by Richard H. Hall .....	14
UFO MATERIALS, by Marge Christensen .....	16
THE NIGHT SKY, by Walter N. Webb .....	19
DIRECTOR'S MESSAGE, by Walt Andrus .....	20
COVER by Golliver .....	

The Mutual UFO Network, Inc. is exempt from Federal Income Tax under Section 501(c)(3) of the Internal Revenue Code. MUFON is a publicly supported organization of the type described in Section 509(a)(2). Donors may deduct contributions from their Federal income tax. In addition, bequests, legacies, devises, transfers, or gifts are deductible for Federal estate and gift tax purposes if they meet the applicable provisions of Sections 2055, 2106, and 2522 of the code.

The contents of the MUFON UFO JOURNAL are determined by the editor, and do not necessarily represent the official position of MUFON. Opinions of contributors are their own, and do not necessarily reflect those of the editor, the staff, or MUFON. Articles may be forwarded directly to MUFON. Responses to published articles may be in a Letter to the Editor (up to about 400 words) or in a short article (up to about 2,000 words). Thereafter, the "50% rule" is applied: the article author may reply but will be allowed half the wordage used in the response; the responder may answer the author but will be allowed half the wordage used in the author's reply, etc. All submissions are subject to editing for style, clarity, and conciseness.

Permission is hereby granted to quote from this issue provided not more than 200 words are quoted from any one article, the author of the article is given credit, and the statement "Copyright 1985 by the Mutual UFO Network, 103 Oldtowne Rd., Seguin, Texas" is included.

# AFRICAN REPORT

By Cynthia Hind

On July 22nd 1985, two BAE Hawk MK 60's were scrambled by the Zimbabwe Air Force from Thornhill Air Force Base, Gweru, to investigate a "bright flying object" over Bulawayo Airport.

According to the report which appeared in *The Herald* newspaper on August 2nd, Commander of the Zimbabwe Air Force, Air Marshall Azim Daudpota said, "This was no ordinary unidentified flying object. Even the two fighter pilots had visual contact with it over Bulawayo."

The object, orange in colour in some reports, was sighted first over Beit Bridge (the border post between South Africa and Zimbabwe) then in Gwanda, West Nicholson and Plumtree, all within Zimbabwe. It was last seen from the Bulawayo Airport Control Tower.

Unfortunately, the radar at the Met. office in Bulawayo had been dismantled for servicing and was not working, although according to Group Capt. Sykes of the Zimbabwe Air Force, it was the fact that the object was picked up on radar that convinced the Air Force of its reality.

## NO BALLOON?

"This immediately rules out that it could have been a balloon," said the Group Capt. "Besides which," he added, "checks were made with the Met office who confirmed that no weather balloons had been launched at that time."

Subsequently, I spoke to Air Commodore Dave Thorne, also of the ZAF and he felt this was a genuine "unidentified flying object." The Air Commodore told me that the two jets were scrambled at 17:45 and were directed to the object which was hovering over Bulawayo at about 7,000 ft. But as the aircraft approached, the object shot up at a great rate of knots (approx. 2,300 kph) to approx. 70,000



ft. Air traffic at Bulawayo Airport was delayed for several hours while the jets were investigating.

One of my investigators in South Africa, Giep Barnard, spoke to Mr. van der Riet of CSIR (Council for Scientific and Industrial Research) and he said, "Supposing a stationary object is in a position of say, 10 km altitude, the view to an observer in an aircraft approaching at a height of approx. 2 km, would be that of an ascending object. Depending of course, on the actual altitudes of both object and observer, speed of observer, distances between observer and object, this theory could hold true and as such an illusion of a rapidly rising object would be created to the viewer."

## TWO PILOTS

The two pilots involved were C. Cordy-Hedge and T.R. Van Rooyen. Both men were 25 years of age. Cordy-Hedge had 1800 flight hours to his credit and T.R. Van Rooyen, 1500 hours.

Cordy-Hedge wrote: 'The object was sighted on the 22nd July, 1985, at an altitude of 4,500 ft. The weather was "dusk-cavok." It seemed to be approx. 15 miles S.E. of Bulawayo. The aircraft

was in a steady climb. I could see the object through the cockpit window and had very good visibility. The object appeared to maintain its distance, but had very fast acceleration at a high altitude before disappearing. It was a bright orange in colour and appeared star-like in shape but was too far away to determine exactly. It moved off in an easterly direction at a very high speed.' Cordy-Hedge estimated that the object had moved from 15,000 ft. to 80-10,000 ft.

T.R. Van Rooyen gave a similar report: he too saw the object through his cockpit canopy and the visibility was good. He, together with Cordy-Hedge, said the observation lasted for 50 minutes. The object appeared as a bright star, initially orange, but of an indefinable shape. It disappeared in an easterly direction at a high speed. He estimated the altitude of the object to go from 15,000 ft. to 100,000 ft.

## ACTION TAKEN

I flew down to Bulawayo, which is some 530 km from Harare, and spoke to N.I. Bull who was the Met officer on duty at the time of the incident. He had written to me in reply to my queries regarding the UFO and I report some of the significant portions of his letter. He said that the previous day, i.e. 21st July, he had picked up several reports of the object being seen over Beit Bridge, Plumtree, etc. No-one seems to know what it was but he took the precaution of alerting the Zimbabwe Air Force at Thornhill. He also heard that the South African Air Force had sent up two of their fighters to investigate but they thought the object was a high altitude research balloon and way above the ceiling of the aircraft.

On the 22nd July, Bull had seen the object almost due south of the airfield at an elevation of 30°. Through binoculars

(continued next page)

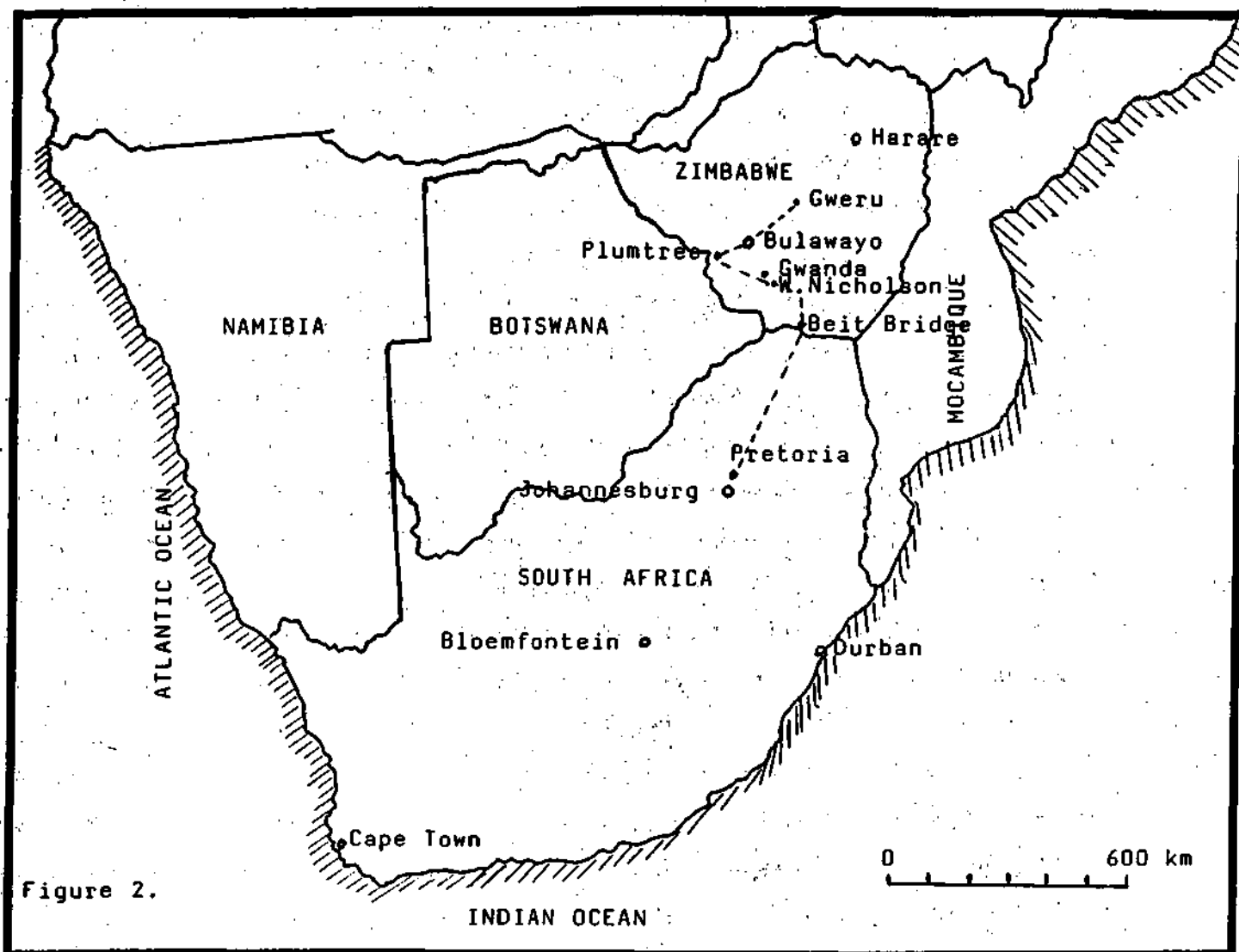

Figure 2.

## AFRICAN, Continued

it appeared spherical and was quite bright and could have been a balloon coated with some sort of metallic reflecting material. Referring to various reports he was able to calculate that the object was between 70,000 and 140,000 ft. up. He heard the Hawk jets pass overhead and a few minutes later the object seemed to disappear from view. All this happened at dusk and Zimbabwe being close to the equator, there is hardly any twilight. It is possible that the sun illuminated the object and when it sank below the horizon, the object could no longer be seen.

There was no radar working at Bulawayo at the time as the Met office radar was being serviced. The Met office balloons are lost between 45,000 and 60,000 ft. and there were none up at the time. *But the wind patterns at high*

*levels up to this height were not descriptive of the motion of the object.*

## WINE GLASS

At this juncture, I had taken a UFO-INTERNATIONAL WEEK Stand at the Harare Show and was approached by two young men from Falcon College (just outside Bulawayo). They had seen the object through a telescope and the one described it to me as disc-like at the top with a trailing object beneath. He thought it might be a weather balloon. At the same time, Maria Sullivan, one of my UFO group in Harare, told me that Mike Williams of Plumtree School had said that two of their teachers had spotted the object and described it as being "like an inverted wine-glass."

This description immediately rang a bell in my mind. On October 31st,

1983, there had been a UFO over Rio de Janeiro in Brazil, with hundreds of witnesses. The Brazilian government eventually issued a statement saying that the UFO had been a South African weather balloon. Irene Granchi, a leading UFO investigator in Brazil, had asked me to look into the matter.

I was friendly with a South African Opposition Member of Parliament who was sympathetic to the UFO phenomenon and had, in fact, asked questions in the South African Parliament about the matter. I contacted him to find out if indeed this could be true. He came back shortly afterwards to tell me that the CSIR were involved with a French Space Agency — *Centre National d'Etudes Spatiales* — who were based just

(continued next page)

## THE REPORTS

At this time, I received several cuttings on UFO sightings. On Tuesday 9th July, Mr. & Mrs. E.A. Lubbe of Steyn Street, Middelburg (Transvaal) saw a light in the sky at approx. 21:45. The light was very bright, stationary and silent. The area was illuminated for a few seconds and then the light began to fade, all in less than a minute.

On the same night, Andre Allen of Kempton Park, near Johannesburg, also saw a strange light in the sky, between 18:30 and 19:00 hours. The Johannesburg Planetarium, while reluctant to commit themselves without more detailed reports, felt the object was a meteorite! By this time, the object had been seen in Reddersburg, Bethulie and the Hendrik Verwoerd Dam area.

On the 15th July, farmers in the Underberg district (Natal) saw a "mysterious shining object" moving towards Lesotho. Mr. Peter Ferraz, former editor of *The Friend* newspaper in Bloemfontein, said "It was extremely bright and moving slowly in a westerly direction. It shone like metal in the sun."

There were other witnesses: Ken and Merrill Macloed, who run the Underberg Met office; Jose Campos, who is head of the viewing section of the S.A. Astronomical Society in Natal, said that the object was not a conventional astronomical object.

On the 28th July, *The Natal Mercury* (Natal) stated that a bright "star" hovering above Natal had mystified many people. But a weather office spokesman at Louis Botha Airport (Durban) had said it was a French "weather" balloon sending signals to a satellite. It was also seen on this date from Durban North, Hammarsdale and Margate.

On the 15th July, the object was identified as a test balloon launched by the French from a site near Pretoria. Mr. Petrus Erasmus of Wilgehof made a sketch of the object which hovered over Bloemfontein. He observed the object through a powerful telescope at his home. (Fig. 1)

(continued on page 19)

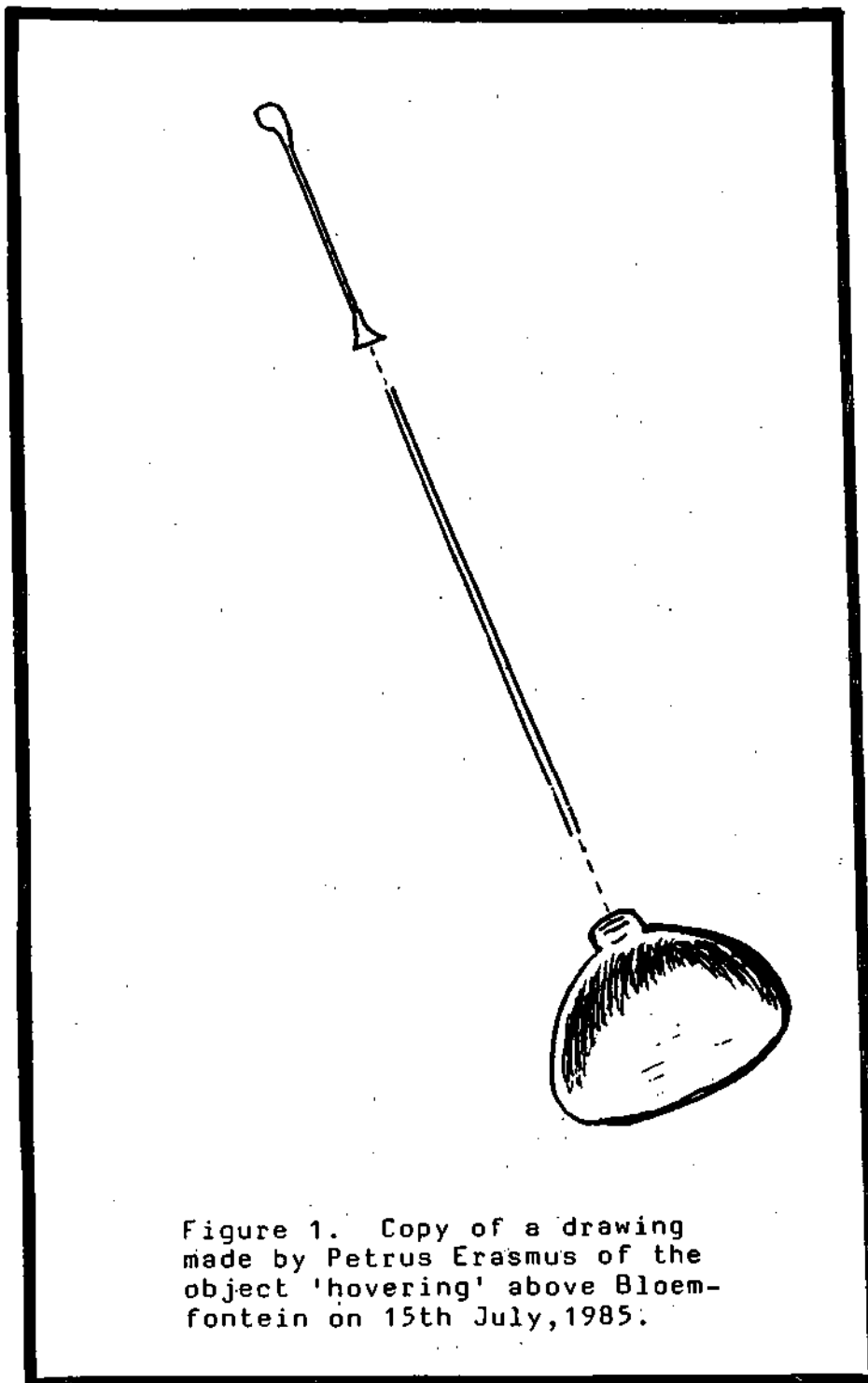

### AFRICAN, Continued

outside Pretoria in South Africa. I managed to obtain a comprehensive description of this balloon.

The balloons are of the infra-red hot-air type. They can reach 30 km altitude during the the daytime and can drop as low as 18 km at night. They drift in whatever currents are in the upper atmosphere and stratosphere. Flight

duration is up to 50 days and a complete circumference of the southern hemisphere has been achieved. The size of these balloons is 36,000 cu. meters, about 40 meters in diameter, and the hull consists to a large extent of aluminized plastic material. There are generally 2 gondolas with scientific equipment attached to them. Radio signals are emitted both to ground stations and to the NOAA satellite.

# FLORIDA FLURRY

By Donald M. Ware

On 20 August 1985, Norman E. Hill, a 43-year old resident of Pensacola, FL, called to tell me about a 1977 UFO sighting. He got my phone number from an article about MUFON in the 19 August Pensacola News Journal. He reported a small salmon-pink light that rose from the woods and transformed, through a transparent stage, into a metallic-gold, Saturn-shaped object with red, blue and green lights around the perimeter.

The object appeared to increase in size as it ascended. Also reported were E/M effects, sound distortion, mental communication, chest and head tightness, skin vibrations, and a deep cold feeling. Our first meeting was an interview in his home on 3 Sep 85, when Forms 1, 3, and 5 were completed. His parents were present and seem convinced he is reporting accurately, although they were skeptical for about two weeks in 1977. Then on 18 October, he drove to Ft. Walton Beach and accompanied me to the sighting area. His story follows.

## COMPULSION

Late on 9 January 1977, Norman Hill was driving from Pensacola to St. Petersburg where he had an appointment with a realtor the next afternoon. As he passed through Bristol, on highway 20, he saw a sign for Ora's restaurant, and he felt a compulsion to go there even though he was not hungry and it was off the highway. About two miles past the turnoff he turned around, went there, and for some unknown reason asked the owners if any UFOs had been seen in the area. The couple that owned the restaurant looked at each other, astonished, and said yes.

Although it was nearly 11:00 PM and closing time, they brought a neighbor in, Mr. Charlie M., who had told of two UFO sightings recently. Norman spent the night in Bristol, and

the next morning Charlie M. took him to the sighting area deep into St. Joe Paper Company property. Then Norman continued to Bristol.

## ENGINE STALLS

On 12 January, while enroute back to Pensacola, he detoured 7 miles north on FL 267, turned east on Sudberry road and continued on the sand road into the paper company woods Charlie M. had shown him. After about a mile his 1972 VW stalled. It would not restart, although the starter and lights operated normally. It was 8:00 PM, almost two hours after sunset.

He saw spires of soft white light come from behind the trees to the south. He got out of the car, and when the door shut, it sounded unusually loud, "like a shotgun blast." He spoke, and his voice "reverberated" and was very loud. He heard footsteps come through the woods from the direction of the light spires, but could see no one. The footsteps moved behind him through the car lights, but he could still see no one.

Soon a bright pinkish-orange ball of light rose slowly from behind the trees where the white light was. There was a stuffy, tight feeling in his head and chest, and a deep cold sensation in his body. As the light rose up, its brightness went down and a transparent Saturn-shaped object (larger on top) started forming around the bright center. When fully formed, the central light was gone, and the object looked solid metallic-gold with red, blue and green lights around the perimeter.

The cold sensation continued, and "vibrations" played over his body and caused a slight euphoria. He said, "I asked the question where this object was from, and received a very mechanical sensation in the head and a knowing that it originated in another galaxy." He felt he was communicating with a computer. He said the object

appeared larger, rather than smaller, as it rose up until it looked about seven times larger than the moon. Within five minutes it rose to the base of thin moonlit cirrus and departed to the east. He thinks the closest he saw it was about 1500 feet. However, there is little basis to determine actual size or distance. After it departed he drove around and sat in the woods for over two hours and saw nothing else.

## TEACHER

Norman has a BS in Biology and Physical Science from Florida State University, and, through a National Science Foundation grant, became qualified to teach high school Physics and Chemistry. He taught in St. Petersburg until March 1976, and is now employed by an industrial security firm. Following this sighting, he reported it to Tyndal AFB. Various officers showed little interest, and a Colonel gave him Dr. Hynek's CUFOS address. He wrote Dr. Hynek a letter on 23 Jan 77, but got no reply.

During the next four months, he returned to the site five times and claims to have seen a UFO three times. One was a high fly-by one month later. Two months later he was alone and said he saw the reverse of his original sighting. A Saturn-shaped object with lights around the perimeter transformed to a bright ball while descending toward the woods and finally disappeared behind the trees. Then on 1 May he and a friend saw an unidentified night light there. He blinked the car lights three times and it also blinked three times.

Norman claims to have more than his share of ESP, and before his divorce in 1972 experienced psychic communication with his wife. He said his psychic ability sometimes fluctuates but has not changed noticeably since

*(continued next page)*

## FLORIDA, Continued

his UFO sightings. He claims to have experienced several other UFO or psychic events:

### PSYCHIC

a.) In Nov 67, he saw a very high oval object fly over with lights around the perimeter.

b.) In Dec 72, while grading physics papers, he somehow received a description of soft white-skinned people and some information about a formula concerning the force of gravity.

c.) In June 74, he was on his bed in Pensacola when he had a vision of a 14-year old girl in his class in St. Petersburg. She reached down, and as he took her hand it felt life-like. As they "went for a walk" he could see his body on his bed. When he next saw her he did not mention it, but she asked if anything particularly strange happened to him that summer. When he said, "Yes," she described how she went for a walk with him in an out-of-body experience.

d.) In Oct 76, he saw the upper half of two different looking entities appear near the ceiling, a white-skinned female and a grey-skinned male. He got the impression one was the guardian angel of his mother and the other of his father. They were trying to determine which was responsible for him.

e.) In Apr 83, again while resting on his bed, he saw a black silhouette of a large-headed man appear from the wall and stand in the doorway. No light came through the shape. Then a green arm "came out of the lamp shade" and he heard voices talking about the green snake. He said, "Its not a snake, its an arm," and a mental voice, sounding surprised, said, "If you can hear this raise your left hand." When he did, the silhouettes and "voices" vanished.

f.) Finally, in Apr 84, he went into his back yard about 1:30 AM and saw a one-foot diameter brilliant white light flash momentarily about four feet above the ground. When he went back out a little later, the same thing occurred, and he got a mental message asking if he knew anyone who was ill.

### SUMMARY

These unusual occurrences involving Norman Hill are certainly strange. He does not seem either disturbed or obsessed by them. His latest hobby is growing carnivorous plants. His interest in UFOs seems to be based on a general curiosity about the science they seem to represent. Nor does he seem overly interested in psychic phenomena, but he and his parents seem convinced his ability to receive psychic messages is much stronger than most. It has not been tested. I consider his 12 Jan 77, UFO sighting an ordinary unknown because, although the report was highly strange, it was a night light without supporting witnesses. Arrangements have started for our investigator in Gadsden County to interview Mr. Charlie M. concerning his UFO sightings in the same area.

### CASE 2

One 26 June 85, Charles M. White heard my lecture on UFOs at his Methodist church and told me of his 1974 sighting. He reported a glowing, convex-sided, disc-shaped object that blinked on and off repeatedly as it flew over his home in a clear afternoon sky. During an interview in his home on 15 Oct 85, he reported the following information.

### CONVEX

He was mowing his front lawn one August afternoon in 1974, facing west, when he glanced up and saw a strange object moving to the east across a clear sky. His first reaction was to yell to his wife in the house to get the binoculars and come outside (she confirmed this). When she got out about 40 seconds later, the object was going out of view behind the trees. The object appeared circular when first seen and when last seen. However, as it moved through its closest point, about 60 degrees above the southern horizon, he could see the clear-outlined shape of a convex disk standing on edge.

The strangest thing is that it continually blinked on and off about every three seconds. The on-time equaled the off-time, about 1.5 seconds. When on, it looked like a large, white

fluorescent light. When off, he could see nothing unusual. He thinks it was 3000 to 4000 feet up and moving about 300 mph. Unfortunately, there were no other witnesses to help determine size. It appeared twice the size of a full moon.

### RETIRED NAVY

Mr. White is a 66 year old retired aviation metalsmith for the U.S. Navy, and was also an active reservist. He was a crewmember on antisubmarine aircraft, and still enjoys excellent health. He told us he also had two night UFO sightings, one before and one after this 1974 sighting.

In the summer of 1959 he was driving from New Orleans to Pensacola about 9:30 PM with his commanding officer, a Navy Captain. After crossing the Mobile causeway, they turned south on a two lane road. They rounded a turn about one-half mile south and saw a large round light "like a moon" hovering over the road perhaps a mile away. They stopped the car and got out. It was like a white fluorescent light that lit up the road. "You could read a newspaper by it." Its diameter was 60 feet to 100 feet, at least three times the road width.

They heard no sound. They both said, "I see it, but I don't believe it.", and they made a pact not to tell anyone "because they will tell us we are crazy." For five minutes it didn't move. It suddenly went straight up and abruptly stopped. Then it went straight west and abruptly stopped. It hovered for a few moments, and blinked out as it got back over the road.

In 1978 Charles was looking out of the rear viewing window of a P-3, Orion, at 22,000 feet. Heading northeast near Atlanta, Georgia, he saw a round, white, fluorescent-like light that appeared to be 2000 to 3000 feet above the ground. It was moving in the same general direction they were until it abruptly stopped and hovered. Then it headed about 90 degrees away, stopped, then made an arc and blinked out. He said it was identical in appearance and maneuverability to the one he saw in 1959. He did not tell anyone, because he thought they would

(continued on page 17)

# MASSACHUSETTS FORUM

By Walter N. Webb

Massachusetts MUFON's second annual UFO Forum was held at the Beverly Golf and Tennis Club on the weekend of August 17 and 18, 1985. By all measures, the one-and-a-half day affair was a huge success. The year's attendance doubled last year's figure; the 300 persons hailed from 17 states and Canada, coming from as far away as Hawaii, California, and Florida. Eleven state directors were represented. Even the weather cooperated, with both days delightfully cool and sunny.

## MEDIA ATTENTION

The event attracted much local media coverage. Boston's WBZ-TV and Natick's cable TV station videotaped and interviewed speakers at the Forum (a WBZ segment was aired on "Evening Magazine" September 16; further spinoffs are planned by the station). Busy speakers appeared on five radio talk shows, and area newspapers, including the *Boston Herald* (two stories), carried feature articles.

## HYNEK AWARD

Massachusetts MUFON Director and Forum organizer Marge Christensen delivered her opening remarks at 2 PM on the first day. She then presented Dr. Allen Hynek with a special edition of the Computer Catalog of UFO Resources. The document's supplement listed all catalog references to the astronomer's name and was offered to him in recognition of his outstanding work in the UFO field.

## FRENCH CONNECTION

Returning this year in a different role as moderator of the Forum, UFO historian Dr. David Jacobs of Temple University introduced Dr. Hynek, who



JOHN F. SCHUESSLER

—Dennis Stacy

was to talk on "The French Connection" — an account of his recent trip to France at the invitation of the French space agency. The CUFOS Director, however, wasn't feeling well and so Dave did a superb job in reading Dr. Hynek's notes.

As guests of the French National Space Center and GEPAN, the official UFO agency, Drs. Hynek, Niemtow, and Vallee not only attended a two-day UFO conference in Paris and Toulouse but also presented papers that were well received (See August 1985 issue). Hynek's paper centered on the activities of CUFOS; Niemtow's, on UFO-related medical injuries; and Vallee's, on the computerized screening of UFO reports. Jean Jacques Velasco, Chief of GEPAN, asked the three to serve as a "scientific liaison" between GEPAN and U.S. ufologists.

With both France and the Soviet Union now conducting official UFO investigations, Allen Hynek's paper concluded by posing the question: "What will it take to get NASA and our government to make a similar move?"

## CASH-LANDRUM

John Schuessler, MUFON's Administrative Deputy Director, was next with his oft-told-but-always-riveting account of "The Cash-Landrum Case." John's well documented investigation of this famed medical injury episode has been ongoing since it happened five years ago (it has been discussed frequently in the pages of the Journal). The three victims still suffer from a variety of radiationlike effects; the list of physiological

(continued on next page)



PETER GERSTEN AT SAINT LOUIS

—Dennis Stacy

## FORUM, Continued

symptoms in this single incident seems almost unending.

To this day, no agency admits to sending up the two dozen helicopters that surrounded the UFO that night, and no Federal agency has paid for the countless treatments and hospital visits endured by the witnesses. Although New York attorney Peter Gersten has filed suit in Federal Court in behalf of the victims, John commented that prospects for a ruling in favor of the Texas witnesses were not particularly bright.

## UNICAT

Final speaker on day one was

Florida physicist and CUFOS researcher Dr. Willy Smith, speaking on "UNICAT: A Scientific Approach." He and Dr. Hynek have developed a new computer file of high quality UFO sightings called UNICAT (for "Universal or Unique Catalog"). The idea is to come up with a collection of case data that "will withstand the most severe scrutiny of the scientific community," according to Dr. Smith.

The cases selected for UNICAT must first survive three basic criteria: They must have two or more witnesses (very good single-witness episodes won't be excluded), have been written up in a detailed report by qualified investigators, and contain at least the basic parameters sufficient for inclusion in the catalog. Dr. Smith outlined ten

groups of 219 possible parameters; physical description, luminous description (lighting), dynamics (flight behavior), observers, UFO intelligence (explicitly or implicitly indicated), UFO-observer interaction, UFO-environment interaction, entities, probatory elements (photos and physical evidence), and miscellaneous.

Initially, 400 cases were selected for UNICAT Phase One from CUFOS files. Fifty-one percent consisted of close encounters, and 74 percent were multiple-witness incidents. Smith illustrated his talk with slide graphs demonstrating some of Phase One's preliminary findings.

A private dinner attended by 60 persons rounded out the day's activities.

## TOUGH TALK

Opening the second day's program at 9:30 AM, Dan Wright, Michigan State Director and author of the Field Investigator's Exam, delivered a hard-hitting presentation titled simply "Tough Talk for Investigators." Many considered it the highlight of the Forum.

Good UFO investigators, Dan pointed out, are well prepared. "There is no room for bias, sloppiness, and incompetency," he remarked. It is up to us to have a thorough understanding of IFOs, to carefully study such guidebooks as the *MUFON Field Investigator's Manual*, to establish and maintain contacts with such local agencies as police departments and airport control towers, and to rely upon a checklist to insure that no essential piece of equipment is left out on witness interview trips.

Conducting a proper interview is crucial. Dan admonished investigators on such matters as being objective and unbiased during the interview, allowing the witness to recount the whole incident first without interruption, listening effectively, controlling body language, and avoiding questions that might lead the witness.

## QUESTIONS

(continued next page)



DRS. HYNEK AND WILLY SMITH IN SAN ANTONIO

—Dennis Stacy

## FORUM, Continued

The speaker asked state directors if they were filling their roles, that is, recruiting a qualified investigative team along with drumming up a MUFON membership. Do they hold regular meetings, have local MUFON consultants and other professionals address the group, make available audio-visual resources to members, and administer the new Field Investigator's Exam to trainees? Dan then exhorted: "If not, why not?"

"I'm just as tired as you are of the cheap shots by debunkers," concluded the speaker. "I'm tired of newspaper reporters getting away with calling us 'UFO buffs'....Let's stop making it so easy for them. Let's get our own house in order and silence skeptics once and for all."

## ABDUCTION MOTIVES

Coming back from last year's Forum to update us on his latest findings, *Missing Time* author Budd Hopkins talked on "The UFO Abduction Phenomenon: A Speculation on Motives." He began by

showing slides of scooplake and linear childhood scars of undetermined origin in the flesh of various abductees, including both the mother and daughter of the Kitley Woods, Indiana, series of events. Could such scars represent tissue-sampling by alien captors?

Budd then referred to cases of implants allegedly inserted into the nostrils, eye sockets, and ears of abductees. He inferred that such implants might be used as locating devices, for introducing information into the brain, or for removing information. For the first time this fall, the speaker said, two or three witnesses will undergo CAT-scans in an attempt to unmask these alleged devices.

## UFO SEX?

The remainder of the New York artist's talk centered on "the most disturbing part of this whole disturbing business," and he was frank to admit that the inferences that he would make were "highly speculative." A number of cases still under investigation implied that male and female abductees were subjected to such procedures as

artificial insemination, sperm collection, acts of intercourse, and, at least in one instance a follow-up abduction where the fetus was removed.

These shocking tales of implants and genetic tampering provide further evidence to Budd Hopkins that individual humans are not only being monitored by UFO entities but also may be guinea pigs or hybridization experiments.

## SECURITY UPDATE

Also returning from the '84 Forum, *Clear Intent* co-author Barry Greenwood completed the weekend program by speaking on "Clear Intent Plus One." He reported that 7,000 pages of UFO-related documents originating from at least a dozen governmental agencies have now been released through the Freedom of Information Act. But he also said a large amount of material is still being withheld. Barry urged that anyone shown a secret UFO report should remember the title, precise date, author, and/or ID number of the report rather than the text itself; "identifiers" are far more useful in tracking down the document through the FOIA.

Barry, who is Research Director for CAUS (Citizens Against UFO Secrecy), discussed some of the results of recent FOIA requests. According to one FAA document released in 1984, a NORAD phone number was given out (perhaps inadvertently) to a citizen reporting a UFO sighting. The number was stated to be the Air Force unit investigating UFOs. NORAD now denies the existence of such a unit and in fact has changed the phone number!

The speaker described two anomalous reports based partly on files obtained from the FAA and the Coast Guard. The former detailed an account of the strange rising cloud formation witnessed by six airline crews off Japan on April 9, 1984--still unexplained.

And the other sighting concerned the Puget Sound fireball of July 27, 1984, which splashed into the water. Local divers claimed that they spotted a strange disclike object buried in the

(continued on page 17)

# THE MEIER CASE

By James W. Deardorff

In making a trip last June to Schmidruti, Switzerland, where Eduard Meier and family lives, I had hoped to interview some of the secondary witnesses to the case. However, Frank Stuckert, the English-speaking friend of Meier and his small group of message disseminators, who often act as interpreter, was still recovering from an operation at the time, and the secretary of the group who also speaks English quite fluently, B. Zimmerman, unexpectedly had to be in Munich the same week to undergo medical tests. Thus, outside of merely meeting Meier, his wife and their two sons there, and Eva Bieri, the latter four being secondary witnesses, I could do no interviewing at Schmidruti since my German is even worse than their English.

I did look through Meier's four big photograph albums of colored 3½" by 5" prints and order copies of any at 5 SwF each (about \$2 at that time). About 700 of them, taken mostly at 15 different places during 1975-76 and at two other locations in 1981, show the posing UFOs, and another 300 or so show landing traces and other evidence related to the reported contacts. A 61-page listing (in German but being translated into English) describes the times and locations, and associated information. Representative photos from this collection, enlarged, have appeared in the Elders' Vols. I and II.

## INTERVIEW

In Munich I interviewed B. Zimmerman for a day, concerning various questions arising in trying to interpret Meier's voluminous set of contact notes. However, she started working for their group only about 5 years ago and is not one of the two dozen or so secondary witnesses named in Wendelle Stevens' Investigative Report. Over the telephone she helped me briefly

interview one of the secondary witnesses, Guido Mossbrugger, a science teacher, on the credibility of one point out of the hundreds of mind stretching questions raised by the contact notes. Later, by telephone, I interviewed another secondary witness and schoolteacher, Elsi Moser of Zurich, who speaks English fluently. She affirmed that she was a witness to nighttime UFO lights associated with one of Meier's contacts.

## MESSAGE

Thus, what little I could observe on the trip merely confirmed what one would expect of a true contactee and genuine secondary witnesses. They seem dedicated to letting sincerely interested people learn the spiritual message to which they have been exposed, but also dedicated to not turning the affair into a cult with a guru. They are upset to hear that anyone can still feel the affair could be a hoax, and are actually much more interested now in the spiritual message from the contact notes than in affirming over and over the reality of the photographs and movie footage. The spiritual message seems to be the main point of it all, although the contact notes also contain much in the nature of general science.

About 7 of the secondary witnesses live on the premises of the Meier residence. Another several dozen of his supporters, including other secondary witnesses, live nearby in the Zurich area.

To my own satisfaction I have determined that in at least one instance, and in perhaps many more, what was passed off to Meier as science was instead an absurdity purposely inserted into the contact conversations and notes. Few scientists therefore would wish to defend the reality of the purported science in these notes.

However in most instances one is unable to distinguish for sure between

what seems to be an absurdity and what might merely be an indication of advanced alien technology which would seem occult. The reason behind the purposeful absurdities in the contact notes is apparently to keep scientists disinterested, and therefore governments also. Then this UFO case, like all others, will not be the cause of any sudden worldwide realization and panic that UFOs are real and that extraterrestrials are around. This reason turns out to be consistent with general explanations within the contact notes themselves.

## PREVIEW

Before inquiring from Walt Andrus about the availability of Wendelle Stevens' Investigation Report on the Meier case, or of other detailed information on the case, the interested reader should ask the following questions.

1) Would my religious views, if any, be incompatible with a universal spiritual message from aliens whose civilization dates back hundreds of thousands of years? Would I refuse to question the basis of my own religious faith?

2) Do I believe that our present day science is near the pinnacle of what science of the future could ever achieve, and that no alien race tens of thousands of years in advance of us could perform acts which to us would seem like magic or put science fiction to shame?

3) Would I allow what I read in the contact notes to influence my judgement on the degree of validity of the physical evidence involved in the case?

If your answer to any of these is yes, there is no point in your inquiring further into the Meier case, or spending money on the materials.

(continued on page 18)

# RANDLES REPLIES

By Jenny Randles

I have been urged by several people (in America, Australia and Britain) to respond to the "scurrilous attack" on our book *Sky Crash* by Jennie Ziedman (June 1985 MUFON Journal). Unfortunately, my copy of this issue must have vanished into the Bermuda Triangle in transit (as it never arrived) — and it has taken me some time to see a copy of the article, thanks to Ray Boeche. I was expecting the worst, and planning an even more vigorous response than the one already submitted to Lucius Farish's rash statements. However, I received a surprise. Whilst the Farish letter does deeply concern me, since it asserts a number of things I know to be untrue, I found the Ziedman piece fair and reasonable. There is little in it I would quibble over.

## RUMORS

As Brenda Butler and Dot Street's "mentor" on the case, according to Ziedman (although, in fact, I have interviewed witnesses and visited both the site and the base several times), I was myself acutely aware of the lack of direct eye-witness testimony. It was one of the perennial problems of this bothersome case. Much of what I had to work with for the book, by late 1983, was second-hand. But almost none of it was the third-hand material alleged by Ziedman (except whenever supportative anecdotes are quoted). There was some first-hand material (see, for example, the verbatim quotes from "Art Wallace"/Larry Warren in the chapter "The Wallace Tapes.")

Yet her principal point is a valid one. The book is not a scientific discussion of the case and was never intended to be. It was produced in the one and only way such a book could be written in 1983, presenting the mish-mash of rumors, accounts and counter rumors (as confusing and contradictory as they inevitably were).

In fact, had we waited six months to write the book it might have been very different. Probably not. The material on the case of a first hand nature which Ray Boeche collated for MUFON, which we also collated in England, and which is demonstrated on the "Halt" tape recording, largely came as a result of our book. We deliberately aimed to tell what we had so as to stimulate other researchers into digging for paydirt. Sadly, this is a policy which is not being followed by certain other investigators, who are protecting their first hand material for their own reasons — and behaving (in my view) contrary to both the free flow of information and the good of ufology. This is something, at least, we cannot be accused of.

## TIME FACTOR

You must see our rush into print in the light of two things in late 1983. The British media stories forced our hand. We had to counteract the sensationalist rubbish that was emerging with the facts. And we had to do it fast. Also we were induced by the apathy and ridicule heaped onto us from all quarters in our two years of work before 1983.

Yes, in a sense, the book was premature. And we paid for it in sales, because it is not easy to comprehend. But I would do exactly the same again, for we wanted to catalyse others into action in places where some good could be done. We achieved that. So we did all that we expected.

## HALT'S ROLE

Colonel Halt's role certainly is crucial, as Jennie Ziedman says. Why did he set himself up as a scapegoat (or allow himself to be set up)? Why was the carefully contrived "memo" and then the "tape" released when it was? Both these questions are fundamental because they emphasize the importance of the second night (29-30

December 1980), when Halt himself alleges involvement. Since, in my view, it is the *first* night (27 December 1980) which reflects the main event, this shift of emphasis smells fishy to me. There is also nothing on the Halt memo or tape which is inexplicable. Much of it is perfectly consistent with the Ian Ridpath lighthouse theory.

Now I do *not* believe that Ridpath is right, and the lighthouse is the sole (or even principal) stimulus for this case. However, we do have to assess the truth, and the documented evidence which has been "fed" to us seems to support his view. Which may, of course, be precisely the point!

Halt refuses the lighthouse solution. Yet, despite the fact that others have gone public (including Colonel Ted Conrad — who did not suffer for his pains and was promoted to General), plus Halt's claim that he has not had any pressure to prevent him from talking, he has failed to react. You would expect a witness whose observational faculties have been called into such question to reply vehemently. Halt declines to do so.

This is one of many questions still outstanding on this case. Jennie Ziedman does make one point I take issue over. She claims that I state that no people remained on base in 1983 who had been there in 1980. I have not said this. Halt, as a prime example, refutes it immediately! I have always known that there were one or two there who had been since 1980, but none who were involved in the events. They were all moved off. That is a different kettle of fish altogether.

## QUESTIONS REMAIN

I know this case is confusing and would not quarrel with Jennie Ziedman's term "convoluted" for our book. But it is entirely honest. By failing

(continued on page 17)

# NEWS'N'VIEWS

In 1980 Dr. Leo Sprinkle, then Director of Counseling and Testing at the University of Wyoming, invited to Laramie about twenty UFO "contactees" whom he had hypnotically regressed to their UFO encounters. His purpose in bringing them together was to give them an opportunity to share and compare their experiences, to search for patterns, and to consider whether they should "go public" with their stories. A real bond of friendship was established among the fifteen who were able to be there. Since then the annual meeting has been open not only to those who have had personal experiences, but also to UFO investigators and to the interested public.

Although Dr. Sprinkle has lowered his profile in UFO research for personal and professional reasons, his presence and personality still sustain the conferences sponsored by a small enthusiastic Laramie group, PRO-UFO (Paranormal Research Organization for UFO Studies).

Often a person who has been at the MUFON annual Symposium will see familiar faces in Laramie. Last year two speakers, Paul Norman and Hilary Evans, spoke at both conferences. This year Ken McLean, Wyoming State Director for MUFON, who spoke at a special meeting in St. Louis on public relations, was master of ceremonies.

The emphasis in Laramie is still on the personal aspects of the UFO experience. One morning was spent in group discussion, and one afternoon was a closed session, no press or tape recorders, so that speakers could tell their stories to a sympathetic audience in confidence. This brought out some tales that lapped upon the wilder shores of ufology.

In a more down to earth vein, Jerry Clark, Associate Editor of Fate magazine and new editor of the CUFOS International UFO Reporter, discussed with Dr. Hynek's secretary,

Ann Eller, the new CUFOS Center in Phoenix and plans for UFO research there.

The keynote speaker at the banquet Saturday night was Dr. Aphrodite Clamar, the psychologist who has worked with Budd Hopkins. She has done most of the regressions in his encounter cases. Interestingly, the whole battery of tests administered by Dr. Clamar, but graded and assessed by other psychologists, show that people who believe that they have been abducted by a UFO are a pretty average lot; the only personality traits they seem to have in common are those that might be accounted for by the abduction itself.

—By Mildred Biesele

## Clear Intent

The clear intent of the book *Clear Intent* is to prove that 1) there are a lot of unexplained "objects" in our skies, and 2) there is an extensive "government coverup" of this information.

Authors Lawrence Fawcett and Barry J. Greenwood deserve credit for forcing the government to release hundreds of pages of documents on UFO sightings. But they admit right at the start (page 7) that their material is "not earthshaking" and does not prove that the reported UFOs were "absolutely real."

What, then, can we conclude from this massive compilation of UFO reports?

If you, like many people in the UFO movement, believe that UFOs are extraterrestrial space ships and that the government knows this and tries to keep it secret, then this book will help you to believe what you want to believe.

If you, like me, note that there is no proof of even a single extraterrestrial visitor, and suspect that a "government coverup" is more a matter of chance and ineptitude rather than

complicity to withhold information, you will find nothing solid here to support either the extraterrestrial or the secrecy theories.

Fawcett and Greenwood's technique in most cases is to quote extensively from the newly-released material, then pretty much leave it at that. Occasionally they toss in an intriguing although unsubstantiated question, such as "Perhaps even more interesting...is the story of what we haven't been told by the authorities" (p.40). Perhaps, but they give us no material to back up that speculation.

They seem to expect the reader to be impressed by the sheer bulk of unexplained cases. But many of the cases they report are up to almost 40 years old; do we learn anything from trotting out these old and tired cases? Some of the cases happened in other countries; is it legitimate to blame the U.S. government for secrecy if officials at the foreign UFO site did not announce the UFO at the time?

Most importantly: Fawcett and Greenwood do not provide us with much of any information other than the actual report. They seldom suggest the possibility of alternate explanations. They do admit (rather grudgingly, I thought) the possibility that some UFOs may be temperature inversions (p.6), satellite debris (p.10), meteors and fireballs (p.167), or atmospheric disturbance (p.176). They make no attempt to develop the possibility of such explanations.

They make no mention whatsoever of recent Persinger/Brady/Devereaux studies which indicate that unexplained luminosities often form along earthquake faults and areas of stress. They extensively report such situations as sightings at a military base many years ago, without telling us whether alternative explanations might be possible; surely the least they could

(continued on page 16)

# UFO SECRECY

BY  
LARRY BRYANT

When he joined Citizens Against UFO Secrecy a few years ago, Rodney Towers Beaton, then of Westport, Conn., could have been expected to curtail his work as a CAUS research analyst upon resuming his academic studies.

On the contrary, since beginning his sophomore year at the University of New Mexico, Beaton has chosen to align his studies with his activism -- and in so doing has achieved a "first" in UFO research.

Now founding director of the first organized CAUS presence on a university campus -- Students Against UFO Secrecy (SAUS) -- Beaton has recruited about a dozen other UFO-oriented students, has begun plans for a newsletter, and has secured the services of a faculty advisor, thus accrediting his group as an official student organization.

## UNHIDDEN AGENDA

Besides continuing his research into official UFO documentation, Beaton seeks to have his group sponsor UFO-related lectures at the university, to gather local community support for funding of special projects, and to serve as an example of how students can support the growing call for greater freedom of UFO information.

No stranger to controversy, Beaton already has engendered a bit of resistance to the SAUS effort. "One student told me," Beaton revealed recently, "that he would have nothing to do with a group that uses a negative term in its title -- in this case the term being *Against*." To which Beaton might have responded: "But when you're dealing with a government policy that undermines a fundamental principle of self-government -- i.e., the public's right-to-know -- then you have no choice but to be *against* the policy, in

(continued next page)

MUFON sponsors an annual symposium on UFO research and investigation, typically held in major metropolitan areas each year. Speakers include PhD scientists and others knowledgeable about UFO-related topics. This Index compiles authors names, titles, and subjects discussed. Additional information on availability of Symposium *Proceedings* or article reprints is available from the above address.

## SUBJECT INDEX

### ABDUCTION CASES:

- "Haunting of Kitley Woods: An Ongoing UFO Saga" (Hopkins) 84:168-184
- "Missing Time: A Psychologist Examines the UFO Evidence" (Clamar) 81:76-78
- "UFO Abductions: The Invisible Epidemic" (Hopkins) 81:44-58
- "UFO Contactees: Captive Collaborators or Cosmic Citizens?" (Sprinkle) 80:54-75

**AFRICA, UFO SIGHTINGS**, 81:80-91; 84:65-77

**AIRBORNE SIGHTINGS**, 80:151-177; 83:14-44; 83:174; 84:24-43

### ANIMAL MUTILATIONS AND UFOs:

- "Animal Mutilations: A Decade of Mystery" (Adams) 84:45-63
- "Cattle Mutilations and the Imagined Culprits: A Psychological Perspective" (Jordan) 83:102-111
- "Cattle Mutilations That Defy Conventional Explanations" (Andrus) 83:112-117

**ASTRONAUT UFO SIGHTINGS**, 80:122

**AUSTRALIA, UFO SIGHTINGS**, 84:24-43

**CE-II** (See also Electromagnetic Effects; Medical/Physiological Effects): Africa, 81:80-91; 84:65-77

Bentwaters/Rendlesham Forest, England, 84:100-107

Delphos, Kans., 81:105

"Close Encounters of the Second Kind: Physical Traces" (Phillips), 81:93-129

Indianapolis, Ind., 84:168-184

Physical traces, UFOCAT study, 80:31-52

Sound/radiated energy, 83:128-168

UFO light beams/effects, 84:121-138, 178

White Acres, Australia, 84:37-38

**CE-III** (See also Abduction Cases):

Africa, 81:80-91; 84:65-77

Bentwaters/Rendlesham Forest, England, 84:100-107

"Entity Enigma" (Evans), 84:79-90

Project VISIT humanoids study, 80:14

Spencer, Ind., 84:178-179

Tyler, Tex., 80:132

"UFO Contactees: Captive Collaborators or Cosmic Citizens?" (Sprinkle): 80:54-75

UFOCAT humanoids study, 80:31

**CRASH/RETRIEVAL CASES**, Roswell, N. Mex., 81:132-153; 82:85-104

### ELECTROMAGNETIC EFFECTS:

Aircraft, 83:14-44

Earth Stress Theory, 82:34-40

"UFO Interference With Vehicles and Self-Starting Engines" (McCampbell), 83:46-59

### ENGINEERING:

"An Approach to Determine 'What Are They?' " (Kissinger & Schuessler), 80:14-29

"UFO Propulsion Model" (Alzofon), 82:42-48

"UFO Propulsion: Pulsed Radiation and Crystalline Structure" (Holt), 83:128-168

(continued next page)

## GOVERNMENT DOCUMENTS:

"What the Government Would Know About UFOs If They Read Their Own Documents" (Gersten), 81:21-33

"UFOs: Uncovering the Ultimate Answer" (Moore), 83:83-100

"UFO Secrecy 84: Big Brother is Watching Them" (Greenwood), 84:92-107

## HELICOPTERS, MYSTERY:

Animal mutilations, 84:45-63

Cash-Landrum case, 82:50-64

## HUMANOID CASES (See CE-III)

**HYPNOSIS**, Abduction Cases, 80:54-75; 81:76-78; 84:168-184

IFOs, Satellites and Space Launches, 80:122-129

**INSTRUMENTS** (See also Photos/Photoanalysis), "Instrumented Sensing, Recording and Documentation of Transient Phenomena in UFO Events" (Stanford), 80:151-177

**McGUIRE, PAT L.** (Contactee), 80:61

## MEDICAL/PHYSIOLOGICAL EFFECTS (See also CE-II):

Cash-Landrum Case, 82:50-64; 84:109-119

Earth Stress Theory (Persinger), 82:34-40

"Preliminary Analysis of Medical Injuries as a Result of UFO Close Encounters" (Niemtzow), 80:131-137

## OCCUPANT CASES (See CE-III)

## PARAPSYCHOLOGY:

"UFO Phenomenon and its Relationship to Parapsychological Research" (Owen & Owen), 82:26-32

Indianapolis, Ind., incidents, 84:180-182

## PHOTOS/PHOTOANALYSIS (See also Instruments):

"Instrumented Sensing, Recording, and Documentation of Transient Phenomena in UFO Events" (Stanford 1977 movie film), 80:151-177

New York and Connecticut "Boomerang," 1983, 84:140-161

## PHYSICAL TRACES (See CE-II)

## PHYSICS/PHYSICAL THEORY:

"Flying Saucer Technology" (Friedman), 80:139-149

"UFO Propulsion Model" (Alzofon), 82:42-48

"Unified Field Theory and the UFO" (Montieth), 80:77-101

"Hyperspace (Virtual State) Engineering" (Bearden), 80:104-120

**PILOT AND AIRCREW SIGHTINGS**, 83:14-44; 83:174; 84:24-43; Australian pilot disappearance case, 84:30-43

**PROJECT VISIT**, 80:14-29

**PROVISIONAL INTERNATIONAL COMMITTEE FOR UFO RESEARCH (PICUR)**, 82:66-78

## PSYCHOLOGY:

"Entity Enigma" (Evans), 84:79-90

Psychological testing of witnesses (Clamar), 81:76-78

Questionnaire study of attitudes (Sprinkle), 80:54

**RELIGION AND UFOS**, "Faith, Theory and UFOS" (Downing), 81:35-42

**SOCIOLOGY**, "Human Factors in UFO Sightings" (Westrum), 81:60-74

## THEORIES:

Animal Mutilations and UFOs, 83:102-111; 83:112-117; 84:45-63

Earth Stress ("Geological Lights"), 82:34-40

Extraterrestrial, 83:119-126

Hyperfield Resonance, 83:128-153

Hyperspace, 80:104-120

Orthoteny (Straight Line Theory), 83:61-81

Parapsychology and UFOs, 82:26-32

Secrecy, 83:83-100; 83:170-181; 84:92-107

UFO Propulsion, 82:42-48; 83:128-168

Unified Field Theory, 80:77-101

**UFOCAT** (Computer Data Base), 80:31-52

## SECRECY, Continued

the same way that Mothers Against Drunken Driving and the Anti-defamation League are *against* particular threats to civilized society."

## NETWORK

Beaton's work with CAUS/SAUS ought to inspire other students across the nation to form their own groups in a networking fashion to share ideas, advance local research, and contribute toward a speedy academic, legal, and legislative resolution of the issue of UFO secrecy. Students desiring to coordinate with him on such matters may write to him direct at 202 Stanford Drive, Albuquerque, NM 87106.

## OPPORTUNITY

If the UFO-oriented student population in this country and abroad can mobilize the same level of public demonstrations and rhetorical challenges that occurred back during the Vietnam era, the days of the Cosmic Watergate would come to an abrupt end.

Every fall the CAUS Washington, D.C., office receives a few requests for informational material from students working on their UFO-related term papers. Do you recall Dr. Edward U. Condon's remark about how such students are wasting their time? Well, I wonder what he'd say about that issue now that the recent "FOIA explosion?" of government-generated UFO documentation has afforded all researchers a wider perspective on the UFO problem? Finally, will any of these students eventually produce a doctoral dissertation on the intellectual, societal, and philosophical importance of that growing body of documentation?

Let us hope so.

# MUFON

103 OLDTOWNE RD.  
SEGUIN, TX 78155

# UFO STUDY MATERIALS

By Marge Christensen

## SLIDES

The following new materials are now available for purchase by MUFON State organizations or interested individuals: Slide package containing 50 slides with narrative and slide box. This set is appropriate for use either in public education endeavors or for use with investigator training sessions. Cost of package is \$25.00. Additionally, an expanded 100-slide set may be purchased for \$45.00. This set includes the original 50 slides and 50 other slides. This set may also be used for either public information or for investigator training. Topics covered include a spin through the solar system, IFOs, UFO photos, important people in the field of UFOlogy, important cases, government documents released under the Freedom of Information Act, etc.. The slide sets may be purchased from Dan Wright, 1502 Marquette, Lansing, MI 48906. Checks should be made payable to Dan Wright.

## VIDEO

Massachusetts MUFON has produced a documentary geared for a 60-minute time slot, and available on either 1/2" or 3/4" videotape, with either VHS or Beta format. The program, hosted by Dr. David M. Jacobs, U.S. History Professor at Temple University, and author of *The UFO Controversy in America*, also includes segments with the following persons: Dr. J. Allen Hynek, Walt Andrus, John Schuessler, Budd Hopkins, Barry Greenwood, Dan Wright, and Raymond Fowler. The program is entitled, *UFOs: A SCIENTIFIC ENIGMA*, and covers UFO research organizations, how cases are investigated, UFO photographs, abduction cases, famous cases, a historical overview of the UFO subject, U.S. Government involvement in the UFO subject, Government documents

released under the F.O.I.A., the Cash-Landrum case, the Kirtland AFB case, and the RAF Bentwaters/Woodbridge case.

Dr. Jacobs provides an introduction and also a concluding statement. The price of the videotape is \$20 for 1/2" tape (either VHS or Beta) and \$50 for 3/4" tape (either format). Orders should be sent to Marge Christensen, 2 Cherry Road, Beverly, MA 01915. Make checks payable to: Mass. MUFON, Inc., and please specify size of tape and format desired.

## CATALOG

Finally, a one-of-a-kind computer catalog of UFO resource materials and their locations at various UFO Regional Resource Collection Centers across the country is available from David Christensen, 2 Cherry Rd., Beverly, MA 01915. The catalog is the most extensive of its kind in existence, and includes listings for books, periodicals, video-cassettes, audio cassettes, news clippings, and microfilms. In addition, a supplement covering close to 1000 articles on UFO subjects from popular periodicals is available. At a later date, it is anticipated that a supplement listing government documents obtained through the FOIA will be available.

The catalog includes several helpful types of information about each item listed, such as length, location, content, etc. The catalog is available in an expandable binder to allow for updates and supplements to be added. Current price is \$30.00, payable to David Christensen. The catalog will eventually be offered for purchase to university libraries and major public libraries.

## TIME & MONEY

All of the items mentioned here involve literally huge amounts of time,

energy, research, and funds for the persons involved in their production. All of these items have been compiled and made available to our ranks for the purpose of furthering the causes of UFO research and public education of the subject. They will be of little value if they are not used on a wide scale by all of our MUFON State organizations. It is now incumbent upon every serious UFO researcher and all State organizations to support these projects by obtaining these materials for their respective geographic areas and putting them to use.

In the past these materials did not exist, nor did the incredible mutual cooperation and national cohesiveness in our organization which has resulted in making these materials possible today.

In the past there have been outcries from our ranks as to the need for such resources to be made available. Now that they have become a reality, it is time to back up those outcries with actions and to begin to implement these new materials in order to assist in advancing the stature of the UFO subject and to further the cause of serious research into the phenomenon.

---

## NEWS'N'VIEWS, Continued

have done would be to find out and report whether the area is along an earthquake fault.

Like so many UFO partisans, Fawcett and Greenwood frequently commit what might be called the "craft fallacy": someone sees a light in the sky and refers to it as a "craft" or "vehicle," even though the strong possibility remains it might be just an anomalous light. In one case they give us the text of a 1976 report from Tunisia about a light which "seemed" to touch down near Jerba airport, but then restate it in their

(continued on page 17)



**BUDD HOPKINS**

—Dennis Stacy

### **FORUM, Continued**

mud at the location.

Dave Jacobs summed up the proceedings nicely by capsulizing each speaker's paper. The content of the papers indicated to him that pieces of the UFO puzzle were slowly beginning to come together but that with increased knowledge came more questions. The moderator praised the volunteer efforts of the speakers and of UFO investigators everywhere.

A panel discussion followed. Questions were entertained from the audience for 50 minutes.

Audio-cassettes for each speaker's

presentation can be purchased for \$5.00 from: Mass. MUFON, Box 176, Stoneham, MA 02180.

### **FLORIDA, Continued**

laugh.

Mr. White is a responsible citizen who reported these past sightings to me because he thought I would not laugh. I find it interesting that the said the first and last of his three sightings, 19 years apart, were of objects that appeared identical. I consider all three ordinary unknown sightings.



### **RANDLES, Continued**

to jazz it up as fiction, or tie up loose ends, or present neat answers that simply do not exist, we have clocked up all of 2100 sales in Britain and so many rejection slips (33) from US book companies that our publishers have given up attempting to interest any anymore. The last one to reply summed up the matter — "We don't understand this book. What is it claiming actually happened?"

I don't know what happened! That's the only honest stance. And I am sure I will never put money-making before telling the truth ("warts and all" — as we say in England). You take it or you leave it, but it won't go away.

### **NEWS'N'VIEWS, Continued**

own terms and exaggerate it into a definite "UFO landed near Jerba Airport and took off again" (p.81).

The yawning disparity between the facts they present and the "conclusions" they reach, allegedly from the facts, emerges clearly from their 12-point summary at the end:

"1. UFOs are a real, material, physical phenomenon, completely unidentifiable in conventional terms." (This would be more accurate if the word "completely" were removed, and the words "at this time" were added.)

"2. UFOs display intelligence of a very high order." (Unfortunately, the "intelligence" they display appears to be largely if not entirely in the eye of the beholder.)

"3. Granting that UFOs are real and intelligent, somebody is behind the phenomenon; that is, advanced biological life forms." (Even if you accept the whopping assumption that UFOs are "intelligent," the authors are leaping to an unwarranted conclusion.)

And so for the rest of the 12 points. Fawcett and Greenwood have done a creditable job of gathering raw data, although they have not sought out related material (such as the possibility of earthquake faults in the area) to flesh out this data. And then they have appended invalid conclusions to their insufficient data.

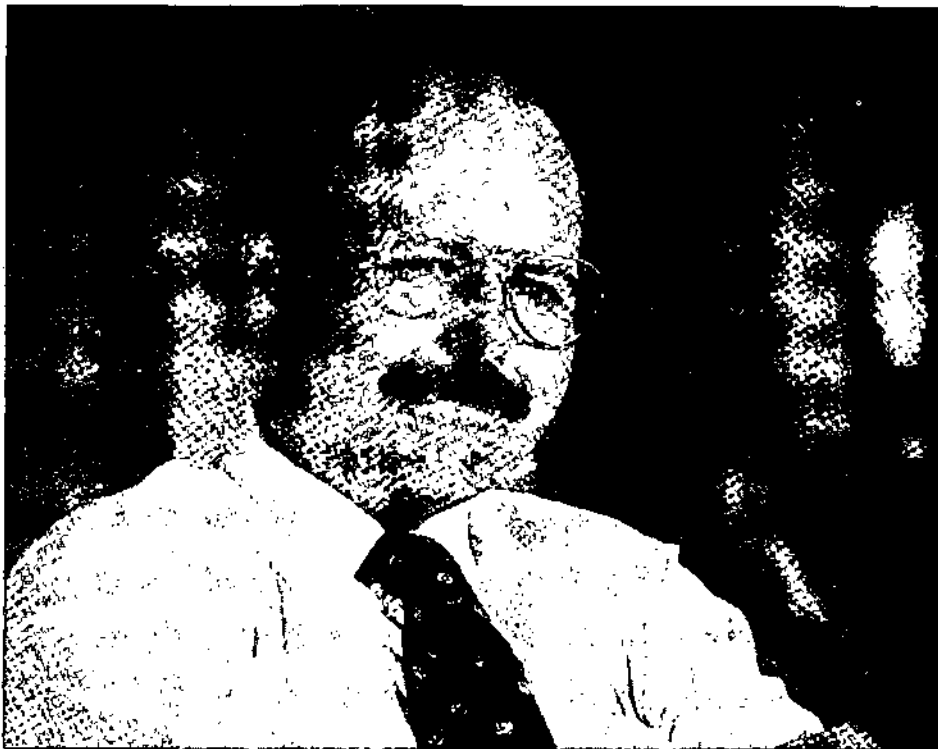

DR. RICHARD F. HAINES

**Richard F. Haines, Ph.D.**, author of the book *Observing UFOs; An Investigative Handbook*, Nelson-Hall, Chicago (1980) has been writing a new book devoted exclusively to the **Frederick Valentich** disappearance of October 21, 1978 over Bass Strait in Australia. **Paul B. Norman**, State Director for Victoria, has shared his personal investigation of this case with Dr. Haines as reported in the *MUFON UFO Journal* and the *MUFON 1984 UFO Symposium Proceedings*. Since this case has never been resolved, Dr. Haines has explored hypothetical solutions in the concluding chapters. The book will be a 300-page trade paperback, 4" x 6½", with photographs. Negotiations are now being conducted with a publishing firm so the price will be announced later in the Journal.

**MEIER, Continued**

No individual trek by any of us to Switzerland now, 5 or 10 years after Meier's main contacts, is likely to reveal nearly as much as what the 20 or so trips made by each of those on the main investigative team of the Meier case has already revealed, as disclosed through the forementioned book and photo volume. There is now also available a 1 and ½ hour video tape on the Meier case which includes most of the "beamship" movie footage.

**Editor's Note:**

*Dr. Deardorff has provided a list of sources of available material on the Meier case that will be mailed by MUFON to people having further interest in this case.*

— MUFON —  
**AMATEUR RADIO NET**  
**EVERY SATURDAY MORNING**  
**AT 0800 EST (OR DST)**  
**ON 7237 KHz S.S.B.**

**AFRICAN, Continued**

can do. Walt Andrus gently reprimanded me for not reporting back to MUFON about this incident more rapidly than I did, but one has to be a little more patient in dealing with Third World countries than with speedy Americans. It all takes time, and in Africa, a little more so.

**MESSAGE, Continued**

scene, due to various reasons. If our members are seriously interested in resolving the UFO phenomenon, they will not allow this fate to strike down MUFON.

\* \* \*

The Center for UFO Studies discontinued their eight page bi-monthly publication, the *CUFOS Associate Newsletter*, with the June-July 1985 issue Volume 6, Number 3, that was edited by **John P. Timmerman** in Lima, Ohio. It will be combined with their bi-monthly *International UFO Reporter* by adding four pages to the IUR and increasing the price for six issues per year to \$25.00 in the U.S.A.

Since the *International UFO Reporter* and the *MUFON UFO Journal* are the only two UFO organizational magazines still being published in the United States, it is imperative that both revise their financial positions for the future. As an example: If the annual membership/subscription price for the MUFON UFO JOURNAL was increased to \$25.00 for twelve monthly issues (20 pages), the subscribers would be receiving a publication comparatively

twice the value of IUR. If the Journal is to retain a professional editor, it will be essential that he/she receive a monthly stipend for their editorial services. A decision and announcement by the MUFON Board of Directors will be forthcoming in the December 1985 issue of the Journal in this regard.

\* \* \*

The Staff of the MUFON UFO Journal is formally inviting members, readers, and former contributors of articles to the Journal, to submit material for publication in future issues. Narrative accounts for investigated UFO sighting reports, photographs and drawings are especially solicited. Consultants and Research Specialists are encouraged to share their UFO expertise by preparing articles for the Journal that are applicable and pertinent to their areas of research. Letters to the Editor are also welcome contributions, provided they are of a constructive nature. The subscribers to the Journal deserve and expect to receive the finest UFO publication in the world.

\* \* \*



Although I was now pretty sure that this is what the Zimbabwean pilots had pursued, I was still not 100% certain. But the matter was further resolved when I received a letter from my contact in Johannesburg, Giep Barnard, whom I had asked to check the matter out with the CSIR. He said, "I have not been able to speak to the person in charge as he is presently on leave. However, I was fortunate to contact his Deputy, Mr. van der Riet." And yes, they had been releasing these high altitude balloons from early in July (probably the 8/9th), the 16th July and on the 22nd July.

CONCLUSIONS

There is no doubt in my mind that the majority of the spate of sightings referred to the space balloon, including those chased by the two Zimbabwean pilots.

Nevertheless, there are several imponderables which must be taken into account. Mr. N.I. Bull, the Met Officer from Bulawayo, did mention that although he accepts that it was the balloon from Pretoria, he could not understand the drift to the NE from Bulawayo (it was seen over Thornhill AFB) later in the evening, as the winds were in a SE direction. Also, there seems no logical explanation for the 'hovering' in one position for such a long time. I had other individual reports (not mentioned here) which also reported this long, hovering stage.

There was also very rapid movement from the Northern Part of South Africa (see Fig. 2) to its movement to Bulawayo in Zimbabwe. And what happened to it after the last sighting at Thornhill? Why was it not seen or reported again?

And the reporting on the 28th July: what could that have been? There were no more balloons released after the 22nd July - certainly not in that month, so what did the witnesses in Durban North, Hammarsdale and Margate see?

I am still trying to trace or waiting for replies from some of the witnesses, but I can't see that there is much else I

(continued on page 18)

THE NIGHT SKY

DECEMBER 1985

Bright Planets (Evening Sky):

The giant planet Jupiter (In Capricornus) gleams in the SW at dusk, setting about 8:15 PM in midmonth.

Bright Planets (Morning Sky):

Mars, passing from Virgo into Libra, is visible in the SE predawn sky. It lies very near the crescent moon on the 8th and in fact, for the SE part of the country, rises behind the moon that morning, emerging from occultation at the dark limb shortly after 4 AM.

Saturn, in Scorpius, reappears in the morning sky but remains very low in the ESE at dawn.

Venus, passing 1° below Saturn on the 5th, can be glimpsed with difficulty low in the SE early in the month. By mid-December it rises only about half an hour before the sun.

Meteor Showers:

The Geminid shower, lasting from about Dec. 7-15, peaks on the morning of the 14th. A fine display should be seen without a moon to interfere. The rate is about 50 per hour. Many of the meteors are bright, white, and slow with short paths. A gibbous moon will bother observers until 3 AM at the peak of the Ursids on the 22nd (15 per hour).

Halley's Comet:

Having passed the earth on its sunward journey, Comet Halley continues to brighten and by the latter half of the month should be visible to the naked eye for the first time in three-quarters of a century. However, moonlight will interfere then. Binoculars will reveal the object during the first half of December in dark moonless skies. As it moves westward across Pisces, the comet arcs below the Great Square of Pegasus, through the Circlet of Pisces between the 12th and 16th, and passes east of the Water Jar in Aquarius between the 26th and 31st. At midmonth look for Halley beginning at 6 PM when it is 50° up in the SSW. It sets 5½ hours later. On the 15th the comet's position is at R.A. 23 h 11m, Dec. +3°6' (1950).

Moon Phases:

- Last quarter--Dec. 5
New moon--Dec. 11
First quarter--Dec. 18
Full moon--Dec. 27

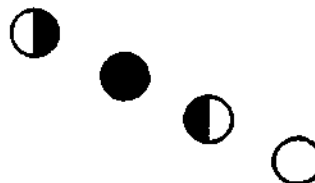

The Stars:

By now in midevening the summer stars have almost disappeared in the NW; the autumn stars are past the celestial meridian in the west; and the winter constellations occupy the eastern sky. The cold seasons' sky symbol, Orion the Hunter, is well up in the SE at 9 PM. Below Orion's trio of belt stars, observe a fuzzy spot in the warrior's sword. It is the Great Nebula of Orion, a glowing cloud of gas and dust--a cosmic nursery for newborn stars.

Beware of that UFO culprit Sirius, which rises in the ESE at 8 PM in midmonth.

# DIRECTOR'S MESSAGE

by  
Walt Andrus

Everyone in Ufology has been vitally concerned about the health of **Dr. J. Allen Hynek** after his two recent surgical operations. A prostatectomy was performed in St. Louis, Missouri shortly after he attended the Massachusetts MUFON UFO Forum in Beverly, Mass. and brain surgery was conducted at the University of California Medical Center in San Francisco, Calif. during October. Your Director visited by telephone with both Dr. Hynek and Mimi at their home in Scottsdale, Ariz. where he is recuperating. I am happy to report that he is regaining his strength and sounded very good on the telephone. I invite our members to personally send greetings and get-well cards to Dr. Hynek at his home address: 7239 East Vista Drive, Scottsdale, AZ 85253.



DR. J. ALLEN HYNEK

It is also a pleasure to advise that **Donald Schmitt**, State Director for Wisconsin, has recuperated from a stomach injury that created a two month confinement.

\* \* \*

The theme for the MUFON 1986 UFO Symposium to be held June 27, 28, and 29 at the Kellogg Center for Continuing Education, Michigan State University in Lansing has been appropriately titled "UFOs: Beyond the Mainstream of Science" to reflect the speakers' presentations and the academic environment. Copies of the *MUFON 1985 UFO Symposium Proceedings*, bearing the theme "UFOs: The Burden of Proof" (180 pages), are still available from MUFON in Seguin, Texas for \$10.00 plus \$1.50 for postage and handling in U.S. Funds. All foreign orders should be by International Postal Money Order or a check made payable against a United States Bank.

\* \* \*

**Michael D. Hart**, in Duvall, Wash., has become so involved in the work of the Compufon Network that he found it necessary to resign from the

MUFON staff as head of Computer Science. We invite anyone trained in the computer field to volunteer their services to fill this important position by contacting your International Director.

\* \* \*

**Michael Brein**, State Director for Hawaii, is proud to announce the appointment of **Kalani Hanohano**, of Honolulu, to the position of Assistant State Director. He is a former State Director for Washington State (1973). Dr. Brein also selected **John T. Dressler** at Hickam AFB to become the State Section Director for Oahu. **Douglas K. Dains**, living in Port Crain, New York, has been the State Section Director for Broome, Chenango, Cortland and Delaware since 1980, however we failed to publicly acknowledge his selection in the Journal.

\* \* \*

Even though we are still looking for an interested and competent person to become the State Director for North Dakota, I want to take this opportunity to announce that **Ralph Ehlers** of Pingree, No. Dak. has become the

State Section Director for Stutsman County. As I pointed out in the September 1985 issue of the Journal, we are searching for people who would be interested in filling State Director vacancies in the states of Alaska, Montana, North and South Dakota, and Puerto Rico. Several existing State Directors have realized that they do not have adequate time, have health problems, or new job responsibilities, preventing them from fulfilling their assigned duties adequately and have asked your Director to seek replacements for them.

We need people to volunteer to become State Directors in Colorado, Kansas, Oregon, Nevada and West Virginia. Please write to MUFON in Seguin, Texas, indicating your sincere interest and qualifications. Many of our State Directors have not selected an Assistant State Director to share their administrative duties, which we encourage and recommend. We are in the process of revising our TELUFONET, so it is imperative that we have enthusiastic state leadership in every state.

\* \* \*

A letter and ballot was mailed to all members of the MUFON Board of Directors on October 7, 1985 to solicit their ideas, recommendations and suggestions on improving the format, contents, style and professional caliber of the MUFON UFO JOURNAL. It was also emphasized that in spite of increased publishing and mailing costs due to inflation over the past 5 years, the annual membership/subscription dues to the Mutual UFO Network have not been increased since July 1980. Preliminary ballot returns stress the necessity for revising the dues structure upward to that MUFON may continue to be a visible UFO research organization financially. We have watched organizations such as NICAP, APRO, and SBI fade from the UFO

(continued on page 18)